

**ATHENS UTILITIES BOARD  
POLICIES AND PROCEDURES  
FOR  
WATER, WASTEWATER, GAS,  
POWER, ACCOUNTING AND CUSTOMER SERVICE**

July 1, 2013

## Index

- Cover Sheet
- Index
- Standard Policies and Procedures
- Division of Accounting
- Division of Power
- Division of Gas
- Division of Water
- Division of Wastewater
- Rules and Regulations

Effective 07/01/13

***Athens Utilities Board – Policies and Procedures Manual***  
***Standard Policies and Procedures***  
***Table of Contents***

		<u>Page</u>
AUB-01	Customer Service Policy	1
AUB-01-01	Customer Information	7
AUB-02	Altering and Tampering with AUB Property	8
AUB-03	Tree Trimming Policies	10
AUB-04	Suspension of Nonpayment Disconnects in Times of Extreme Outdoor Temperatures	16

Athens Utilities Board

<b>AUB Policies and Procedures Manual Standard Policies and Procedures</b>	
<b>Policy Number – AUB-01</b>	<b>Revision Number: 6</b>
<b>Subject Customer Service Policy</b>	<b>Effective Date: 06-25-2013</b>
	<b>Superintendent Approval:</b>
	<b>General Manager Approval:</b>

**1.0 PURPOSE**

The purpose of this policy is to outline the requirements associated with obtaining water, wastewater, gas and electrical services from AUB.

**2.0 SCOPE**

This policy applies to all residential and industrial users who are physically connected or have the potential to be physically connected to the associated AUB utility distribution systems.

**3.0 REFERENCES**

- (1) Athens Utilities Board, Schedule of Rates and Fees, AUB-03
- (2) Athens Utilities Board Division of Power, Policies and Procedures
- (3) Athens Utilities Board Division of Gas, Policies and Procedures
- (4) Athens Utilities Board Division of Water, Policies and Procedures
- (5) Athens Utilities Board Division of Wastewater, Policies and Procedures

**4.0 GENERAL**

Application for original or additional service must be made at the offices of AUB or with a duly appointed agent of AUB and be duly approved before service connection. A meter will not be set or service connected before payment of the service line installation charge and any additional applicable charges or deposits are made.

Any exceptions to this policy will be made at the discretion of the responsible AUB representative.

**5.0 DEFINITIONS**

**AUB** – means the Athens Utilities Board and its duly authorized employees, agents, and representatives

**Board** – means the Chairman and all Commissioners but does not include any employees

**Customer** – Any person, business, or other entity that receives utilities from Athens Utilities Board, any division

**Division** – The Athens Utilities Board, Division of Power, Gas, Water or Wastewater

**Local Control Authority** – Superintendent, director or manager of the responsible division or duly authorized representative

**Service Connection** – Shall mean the point of connection between the customer’s termination point (weather head or meter base) where AUB makes the physical connection to his/her facilities. For meters located elsewhere on private property the service connection is considered to extend from only the tap of the main to the property line, plus the meter and meter installation.

## **6.0 PROCEDURES/POLICY**

### **6.1 Application and Contract for Service**

Each customer or prospective customer desiring original or additional service shall make a formal application with a duly authorized employee of AUB. Residential customers shall provide the following information:

1. Picture Identification
2. Complete Service Address and mailing address
3. Telephone Number and
4. A rent receipt from owner or lease agreement name all adults who will be living at the location for which AUB services are sought from owner (if renting; subject to verification).

Commercial customers may be required or want to execute a formal written contract for the utility service required. Contracts will be written in conjunction with **Section 6.2** of this policy and the specific utility requirements as listed in the appropriate division's Policies and Procedures.

### **6.2 Contracts**

AUB's standard form of application for service is the basic contract for utility service. However, large commercial or industrial customers may be requested to execute a General Utility Contract, which shall contain provisions and stipulations as may be desirable to protect the interests of AUB and the customer. The use of utility services by a customer shall be interpreted as binding the customer by the terms of the applicable standard contract even though such contract may not actually be signed.

If the customer has fulfilled their contract terms and wishes to discontinue service, he/she must give at least three (3) written days notice to that effect, unless the customer contract specifies otherwise. Notice to discontinue service prior to expiration of contract term will not relieve customer from any minimum or guaranteed payment under any contract or rate.

### **6.3 Termination of Service**

Termination of utility services may be performed at the request of the customer or at the discretion of the duly authorized AUB agent. Any customer may order service discontinued at any time upon fulfillment of the service agreement or contract per **Section 6.2 requirements**. Termination of service for any reason shall not relieve the customer of any obligation due AUB under the terms of the service agreement or contract.

When prospective customers apply for AUB service, AUB Customer Service Representatives check AUB's accounts database for the subject property for several parameters, one being the existence of any debt owed to AUB by the applicant or by the owner/Landlord of the property.

If an applicant owes AUB money for previous utility services at any location or for other reasons (such as but not limited to fees, property damage, tampering, etc.), the applicant must pay all outstanding debt to AUB in full before an account can be established for the prospective customers.

In the event the Landlord or owner of the rental property has current or previous debt to AUB at any location that he/she is attempting to rent, the Landlord shall pay all monies owed to AUB regarding any location before AUB will establish an account for the prospective renter.

Only the person in whose name the account is carried may order service discontinued unless specified below. Spouses and children (over the age of 18 acting as primary caretakers of elderly citizens) may also be permitted to order discontinuation of service.

In the event the customer in whose name the account is carried does not occupy the premises and service is ordered discontinued by the customer, AUB reserves the right to permit the occupant of the premises to apply for service at that location such that the occupant will then become the customer. The occupant will then be responsible for all obligation for service rendered at the location effective the date such service was ordered discontinued. The occupant must complete an application for service prior to service connection.

Under no circumstances will AUB become a party to owner-occupant relationships, but shall consider each as individual customers or applicants.

If the customer requests utility services to be terminated, pertinent information such as the customer name, address, telephone number must be provided in order to verify that the authority to discontinue service is credible. Termination of utility services can be performed over the telephone by calling **745-4501**.

AUB may refuse to connect or may discontinue service for the violation of any of its Rules or Regulations, or for violation of any of the provisions of the Schedule of Rates and Fees, AUB-03 or of the application of customer or contract with customer. AUB will use reasonable diligence in supplying utility services, but shall not be liable for breach of contract in the event of, or for loss, injury, or damage to persons or property resulting from interruptions in service.

If the customer has received an overdue-payment notice, he/she has a total of 5 (five) days (including weekends and holidays) to remit the payment in full before termination of services is initiated.

AUB may also discontinue service to a customer for the theft of utility services or the appearance of theft devices on the premises of the customer. The discontinuance of service by AUB for any cause as stated in this policy does not release the customer from his/her obligation to AUB for the payment of minimum bills or outstanding balances as specified in application of customer or contract with customer.

Utility services terminated by AUB and/or the customer shall be subject to the appropriate reconnection fees listed in **Section 6.10**, before service is reinstated.

#### **6.4 Billing**

Bills will be rendered monthly and shall be paid at the office of AUB, via U.S. Postal Service, by phone using accepted credit/debit cards, online at [www.aub.org](http://www.aub.org), or at these other locations designated by AUB:

- BB & T Bank
- Athens Federal Savings and Loan
- Capitol Bank
- Citizens National Bank
- People's Bank
- Regions Bank
- First Security Bank
- Southeast Bank

Please note that banks will not accept payment after the due date has passed on the applicable bill. Failure to receive a bill will not release the customer from payment obligation. If payment is not made by the due date specified on the bill, AUB may discontinue service after a minimum seven (7) calendar days pursuant to AUB Policy AUB-05-06 Pay Agreements and Collections, sections 8.1 and 9.

AUB's standard net payment period for all customer classes shall be not less than 15 calendar days after the billing date.

Bills paid after the due date specified on the bill may be subject to additional charges. Such late-payment charges will be no more than five (5) percent of the unpaid current due balance on the account. Should the due date of the bill fall on a weekend or holiday, payment may be made without penalty on the following business day. Remittance received by mail after the due date will not be subject to additional charges if the incoming envelope bears United States Postal Service postmark of the due date or any date prior thereto.

### **6.5 Minimum Bill Contract**

Prior to construction, AUB may require an applicant for service to sign a minimum bill contract for such amount and for such period of time as may be reasonably necessary to support the utility's investment required, but nothing contained herein shall authorize a minimum bill contract that is prohibited by the applicable rate schedule.

### **6.6 Estimated Bills**

If the employees of AUB are unable for any reason to obtain access to the billing meter, or if AUB has reason to doubt the registration of the meter, or if an error has been discovered in the computation of the bill, AUB reserves the right to render an estimated bill to the customer based on the best information available. If after investigation of the condition, or if subsequent meter readings indicate the estimated bill was incorrect, AUB at its option will either make a compensated adjustment in a later bill, or adjust the estimated bill to compensate for the error.

### **6.7 Customer's Obligations**

If for any reason the customer, after signing a contract for service, does not take the service by reason of occupying the premises, or otherwise, he/she shall reimburse AUB for the total expense incurred by reason of AUB's endeavor to furnish said service.

### **6.8 Taxes**

All taxes imposed by governmental agencies applicable to service to customers of AUB shall constitute an additional charge to the amount billed to any customer under any rate schedule, minimum billing, or other charges for service in accordance with the applicable rate schedule(s).

### **6.9 Customer Responsibility**

The customer(s) whose name(s) appears on the Application for Service shall be responsible for all charges for utility service until a notice is received at the office of AUB ordering the service disconnected. Failure to notify AUB shall not release the customer of any obligation due AUB for any service rendered or made available.

## **6.10 Reconnect Fees**

In the event utility services are disconnected due to nonpayment by the customer, the applicable reconnection fees listed in policy AUB-03, Schedule of Rates and Fees, will apply to reestablish utility service to the customer.

AUB is unable to reconnect any service after 10 p.m., on weekends, or holidays.

## **6.11 Customer Complaints**

AUB strives for 100% customer satisfaction and therefore welcomes all comments regarding the operations and delivery of utility services provided. On occasion, there may be delays or an interruption in utility services due to acts of nature, normal system maintenance or vehicle accidents. If the customer wishes to express positive or negative feedback regarding the quality of services supplied by AUB beyond discussions with a Customer Service Representative, they may do so by contacting AUB general manager, assistant general manager or other appropriate management representative at 745-4501, in written form, via electronic mail at aub@aub.org or by visiting the main AUB offices located at 100 Englewood Road in Athens, Tennessee.

In general, the goal of each member of the AUB organization is to expedite the handling and successful closure of any customer complaint, regardless of the “level” of complaint, the customer’s history, industrial/residential/commercial status, or any other factor. That is not to say that resolution of the complaint will always be exactly what the customer wants. For example, a customer complaining that AUB disconnected their services will not necessarily be reconnected simply in response to a complaint if our records show that the customer failed to honor a pay agreement to keep their services on. However, the complaint should be handled with calm respect and helpful explanation of the situation, why actions had to be taken, and how it could be bettered.

### **6.11.1 In the Field**

When a customer voices a complaint to an AUB crewmember in the field, a decision should be made by that crewmember regarding the handling of the complaint based on his/her role, current knowledge and on other protocols outlined in this policy.

If the complaint is the type that can be fully handled to successful closure on the spot by the field rep then he or she should handle it by answering questions, giving helpful information, and/or noting any follow-up that will need to be done by others within AUB and then ensuring the follow-up needs are communicated to the proper people. For instance, crewmembers should try to take care of complaints pertaining directly to the work area of the crewmember; complaints addressed in handout material carried in crew vehicles; complaints of subject matter on which the crewmember is fully knowledgeable; etc. AUB field personnel cannot make commitments that would financially bind AUB to customer corrective actions. Only the appropriate Local Control Authority or General Manager can authorize financial commitments.

If the complaint cannot be handled fully in the field, he or she should decide who within AUB can most promptly and accurately handle the issue and then communicate the need to that person or his/her supervisor for handling. At no time should a crewmember give answers as definitive if he/she does not truly know for certain, nor should a crewmember simply leave “I don’t know” or “I can’t help you” or similar non-closure responses as an answer for the customer. Likewise, if the complaint needs to be handled by someone in the organization other than the field rep, the field rep should offer to contact that person for the customer, not tell the customer “you have to call so-and-so.” Further, the field rep should



fully brief the AUB colleague on the complaint and current status to facilitate a successful and quick response and closure.

Regardless of whether the complaint is handled on the spot or referred back to the office, the best practice would be for the crewmember to communicate the nature of the complaint back to the assistant general manager so that all pertinent AUB personnel are aware of the issue. This will put AUB in the best position to help the customer if the customer calls back some time later to follow up, ask more questions, etc.

### **6.11.2 In Customer Service**

When complaints come in through Customer Service, whether in person, in writing, or on the phone, a Customer Service Representative (CSR) shall handle the complaint to closure when at all possible. CSRs are empowered to work to the full extent of their ability to gather information from outside entities if applicable, within AUB, the AUB website, policy and procedures manuals, radio calls to the field, or other avenues of information.

Customer complaints should be elevated to a higher level, such as a supervisor or superintendent, only after all avenues of explanation and closure have been worked and where the customer insists on speaking with a superintendent. The CSR should have handled the complaint in a manner that comfortably assures them that the manager's handling of the complaint will be consistent with what the CSR has already conveyed to the customer.

An exception to a Customer Service policy can be made by the AUB assistant general manager, or the Superintendent of Accounting as is pertinent to the subject of the complaint. If necessary and applicable, the decision for an exception to policy may be elevated to the AUB General Manager, as communicated by the assistant general manager and/or the Superintendent of Accounting.

Customers can also file comments and complaints via the AUB web page at [www.aub.org](http://www.aub.org) under the "contact us" section.

### **6.11.3 In Other AUB Offices**

Customer complaints made to other offices within AUB, e.g., a divisional office, the cashier's desk or drive-thru window, the switchboard, or dispatch, should be handled in a manner like that of complaints in the field. If the complaint is the type that can be handled on the spot by AUB representative to whom the complaint has been made, he or she should handle it by answering questions, giving helpful information, and/or noting any follow-up that will need to be done by others within AUB and then ensuring the follow-up needs are communicated to the proper people. Otherwise, the complaint should be passed along to the Director of Communications for dispensation to a CSR or other AUB representative through the appropriate area superintendent.

As with complaints in the field, if the person receiving the complaint cannot handle it fully to closure, he or she should offer to contact the appropriate AUB personnel for the customer. They should not tell the customer "you have to call so-and-so." Further, the AUB representative should fully brief the AUB colleague on the complaint and current status to facilitate a successful and quick response and closure.

## Athens Utilities Board

<b>AUB Policies and Procedures Manual Standard Policies and Procedures</b>	
<b>Policy Number – AUB-01-01</b>	<b>Revision Number: 2</b>
<b>Subject Information to Customers</b>	<b>Effective Date: 03-01-2015</b>
	<b>Superintendent Approval:</b>
	<b>General Manager Approval:</b>

### **1.0 General**

Information regarding all rates, rate classifications, and all policies of the Athens Utilities Board (AUB) are freely available to members of the public via links on the homepage of the AUB website at [www.aub.org](http://www.aub.org). The Rates page is updated monthly to reflect the change created by TVA's fuel cost adjustment for the month. Members of the public can also obtain all rate information simply by coming to or calling the AUB offices. This information is freely available and offered to customers applying for service and can be provided by any AUB Customer Service Representative.

### **1.1 Rate Actions**

AUB communicates all retail rate actions initiated by the utility via local/region media outlets. This includes not only base rate actions or rate changes, but also the effect on rates by every monthly TVA fuel cost adjustment.

### **1.3 Consumption Data**

AUB operates in a fully open and transparent manner regarding all information about the utilities operations, finances, policies and practices. This includes, of course, providing monthly consumption and billing data to customers for any time period they request.

Athens Utilities Board

<b>AUB Policies and Procedures Manual Standard Policies and Procedures</b>	
<b>Policy Number – AUB-02</b>	<b>Revision Number: 4</b>
<b>Subject Altering or Tampering with AUB Property</b>	<b>Effective Date: 10-01-2009</b>
	<b>Superintendent Approval:</b>
	<b>General Manager Approval:</b>

**1.0 PURPOSE**

The purpose of this policy is to outline the requirements and/or consequences associated with the tampering, maintenance or alteration of AUB property.

**2.0 SCOPE**

This policy applies to all residential and industrial users who are physically connected to or have the potential to be physically connected to the associated AUB utility distribution systems.

**3.0 REFERENCES**

- (1) Athens Utilities Board Division of Power, Policies and Procedures
- (2) Athens Utilities Board Division of Gas, Policies and Procedures
- (3) Athens Utilities Board Division of Water, Policies and Procedures
- (4) Athens Utilities Board Division of Wastewater, Policies and Procedures

**4.0 GENERAL**

All equipment up to and including the utility metering boxes are the property of AUB and shall be maintained by only authorized AUB personnel.

Any exceptions to this policy will be made at the sole discretion of the responsible AUB representative.

**5.0 DEFINITIONS**

**AUB** – means the Athens Utilities Board and its duly authorized employees, agents, and representatives

**Board** – means the Chairman and all Commissioners but does not include any employees

**Customer** – Any person, business, or other entity that receives utilities from Athens Utilities Board, any division

**Division** – The Athens Utilities Board, Division of Power, Gas, Water or Wastewater

**Local Control Authority** – Superintendent, director or manager of the responsible division or duly authorized representative

**Service Connection** – Shall mean the point of connection between the customer’s termination point (weather head or meter base) where AUB makes the physical connection to his/her facilities. For meters located elsewhere on private property the service connection is considered to extend from only the tap of the main to the property line, plus the meter and meter installation.

## 6.0 PROCEDURES/POLICY

### 6.1 Utility Distribution Tampering, or Distribution Line Maintenance and Alterations

The service line from the main or distribution line to the customer's meter location shall remain the property of AUB and will be maintained by the applicable AUB Division. All lines, piping and equipment up to and including meter outlet connection shall be the property of and maintained by AUB. The lines and meter set are the wholly owned property of AUB. The customer can in no way encumber AUB's access to the lines or meter set.

All meters, service connections, and other equipment furnished by AUB shall be and remain the property of AUB. The customer shall provide a space for and exercise proper care to protect the property of AUB on their premises. In the event of loss or damage to AUB's property arising from neglect of customer, the customer shall pay the cost of necessary repairs or replacements to AUB.

The customer shall not permit any work to be done, or any device to be installed, which would in any manner effect the proper registration of any AUB utility meter. Any unauthorized work or device installation shall constitute a violation of the service policies and procedures and are subject to service termination by AUB. All persons are cautioned against tampering with the meter or its associated facilities. Individuals who tamper with AUB meters or associated property are subject to a \$500.00 tampering fee that will be applied to the account and may be prosecuted to the full extent of the applicable laws and/or utility codes.

Where applicable, after the customer's lines, piping, equipment and/or appliances have been installed, the customer's installing contractor must contact AUB to arrange an inspection. Upon completion of a successful inspection the appropriate division's lock will be removed from the meter set. *Under no circumstances* will a contractor or customer be allowed to operate, unlock, or tamper with a meter set. *Under no circumstances* will a customer or contractor use any utility in any way except through an inspected and accepted piping/appliance system. AUB reserves the right to refuse or discontinue service to any piping, equipment, or appliances, not in accordance with cited regulatory authority. Any failure to exercise this right shall not render AUB liable or responsible for any loss or damage resulting from defects in the installation, piping, or appliances.

Any alterations or relocation of components for the customer's benefit will be upon AUB approval and at the customer's expense.

The customer shall grant AUB a right of way to enter the customer's property and the unit to inspect and repair the facilities, when deemed appropriate.

All maintenance of AUB-owned property shall be performed **only** by AUB authorized personnel. The customer **shall not**, in any way, attempt to perform maintenance on AUB equipment. Problems with AUB equipment should be immediately reported to the responsible utility division at **745-4501**.

### 6.2 Customer's Responsibility for AUB Property

The customer shall provide a space for and shall exercise proper care to protect the property of AUB on his/her premises. In the event of loss or damage to AUB's property arising from neglect by the customer, the customer shall reimburse AUB for all costs of necessary repairs and/or replacement. The customer shall not construct any structure or

Athens Utilities Board

<b>Division of Power – Policies and Procedures Manual Standard Policies and Procedures</b>	
<b>Policy Number – AUB-03</b>	<b>Revision Number: 4</b>
<b>Subject Tree Trimming</b>	<b>Effective Date: 10-01-2009</b>
	<b>Superintendent Approval:</b>
	<b>General Manager Approval:</b>

**1.0 PURPOSE**

The purpose of this policy is to standardize Athens Utilities Board’s (AUB) approach to tree trimming to provide for reliable service, control costs and for the safety of the general public.

**2.0 SCOPE**

This policy applies to all new and existing customers within the AUB electrical service area.

**3.0 REFERENCES**

- (1) Athens Utilities Board, Division of Power, Rules and Regulations
- (2) American National Standards Institute (ANSI) A300, Standard Practices for Trees, Shrubs and other Woody Plant Maintenance

**4.0 GENERAL**

Any exceptions to this policy will be made at the sole discretion of the Board’s local control authority.

All trimming will be done in accordance with recognized and approved principles of modern arboriculture and tree surgery as specified in ANSI standard A300.

**5.0 DEFINITIONS**

**AUB** – means the Athens Utilities Board, and its duly authorized employees, agents, and representatives

**Board** – means the Chairman and all Commissioners but does not include any employees

**Customer** – Any person, business, or other entity that receives electrical service from Athens Utilities Board, Division of Power

**Division** – The Athens Utilities Board, Division of Power

**Local Control Authority** – Superintendent of Power or duly authorized representative

**kWhr** – Kilowatt-hour, the measurement by which the applicable power rate is purchased

**Service Connection** – Shall mean the point of connection between the customer’s termination point (weather head or meter center) where AUB makes the physical connection to his/her facilities.

## **6.0 POLICY/PROCEDURES**

### **6.1 General Safety**

Customers should remember to look up and look out for power lines when working outdoors. Coming into contact with power lines can cause serious injury or even result in death.

Customers should stay away from power lines when using aluminum ladders, tree trimming equipment, pool skimmers, poles for harvesting fruit or other tools that extend above the head. Metal conducts electricity. Customers will receive a dangerous electric shock if holding a metal pole or ladder that comes into contact with power lines.

The customer should not trim trees that have power lines going through them or that are directly touching power lines or those that have fallen onto power lines. For the health and beauty of the tree and the safety of the customer, AUB recommends contacting a licensed, professional arborist to trim and maintain trees.

### **6.2 Proper Tree Location**

Planted in the right place, a tree can add beauty and value to your home and make your community a nicer place to live. In the summer, trees shade your house from the sun and reduce the temperature indoors. In the winter, trees act as windbreakers, shielding your home from cold winter winds.

However, if planted under or near power lines, trees can be a deadly hazard. Children and adults playing or working in trees that come in contact with power lines can be seriously or even fatally shocked.

Before a tree is planted, make sure the location is out of the way of overhead and underground power lines and other utilities, as required by Tennessee State Law. For AUB's help locating underground lines in the prospective planting area, call **Tennessee One Call at 811**. AUB has compiled a list of tree species that should be avoided and those that are recommended if trees are to be planted near power lines.

#### **Trees to Avoid (planting under/near power lines):**

- Ash
- Elm
- Mulberry
- Locust
- Walnut
- Cottonwood
- Jacaranda
- Oak
- Poplar

**Recommended Trees:**

Crape Myrtle  
Carrot Wood  
Birch  
Japanese Black Pine  
Cherry  
Flowering Pear  
Purple-leaf Plum  
Japanese Maple  
Bottle Brush  
Golden Rain Tree  
Dogwood

**6.3 Trimming Methods**

AUB adheres to the American National Standards Institute (ANSI) A300, Standard Practices for Trees, Shrubs and Other Woody Plant Maintenance. This standard, endorsed by the International Society of Arboriculture, the National Arbor Day Foundation and the National Arborist Association, requires tree-trimmers to cut branches back to the “parent limb.” This practice allows the pruning cuts to “heal” more rapidly, reducing the chances of insect and disease damage, and promotes a healthier regrowth of branches that are directed away from the power lines.

Pruning considerations include: species of tree, growth and regrowth rates, location of trees in proximity to power lines, voltage of power lines, type of power-line construction, length of pruning cycle, natural tree shape and branching pattern, general tree condition, appearance after pruning and tree-owner input.

To reduce damage to trees, AUB uses “directional pruning” techniques instead of the old method of topping off or rounding over trees. Giving trees a “crew cut” by using the rounding over method destroys the tree’s natural shape, and branches cut back to stubs often decay or die. The directional technique, favored by tree-care specialists, involves cutting out the branches that affect power lines, rather than trimming them back.

Directional pruning may give the tree a lop-sided crown or a V-shaped gap in the treetop, but it causes less stress to the tree and may allow the tree to reach normal heights, even if it is directly under the utility line. Directional pruning also reduces the wounds to the tree from frequent pruning.

Below are illustrations of the types of trimming that AUB will perform. The style used depends on how the tree is placed in relation to the power line, and the type of tree that is being trimmed.



In V-cutting, branches are pruned back toward the center of the tree crown.



Side-trimming prunes back branches on the side of the tree.





L-trimming prunes branches to create a “L-shape” in the upper tree crown so power lines can pass to the side and above the tree.

Tree trimming activities will involve a minimum clearance of 15 feet between the tree branches to the closest power line. Limbs overhanging lines will be trimmed as high as possible. All efforts will be made to eliminate weak, diseased and dead limbs above the wires that have the potential to fall or blow into electrical wires.

AUB uses the “natural trimming” method for tree trimming activities. It is called natural trimming because branches are pruned back to a natural point of growth in the crown of the tree. Natural trimming is healthier than tree “topping”, which is the indiscriminate cutting back of tree branches to reduce the size of the tree crown. Although topping generally leaves the tree with a more uniform or balanced appearance, this technique causes stress to trees, making them more vulnerable to insect and disease infections and causes decay.

#### **6.4 AUB Tree Trimming Practices**

Provision of right-of-way easements grant AUB the authority to trim trees without property-owner permission to provide for a safe and reliable electric system. However, AUB respects the property of its customer-owners and will notify the property owner of the need for tree work before trimming is done. In unusual or emergency situations, it may be necessary to trim trees without first notifying the property owner in order to restore service or eliminate safety hazards.

AUB recommends the complete removal of trees that will require extensive trimming on a regular basis. However, trees will not be removed without the property owner’s permission.

To assure proper tree trimming and removal, AUB uses professional tree-trimming firms. It is essential that tree trimming be done properly to ensure dependable electric service and to provide for the welfare of the trees on your property.

The premises of the property where tree-trimming activities were performed by AUB crews or crews contracted by AUB, will be left in the same condition as before the trimming to the extent possible. Crews will chip brush and small limbs. All other wood will be left on the property owner’s premises. AUB is not responsible for cutting wood to size or piling brush.

When possible AUB will give two to four weeks advance notice in an area to be trimmed.

The following priority will be followed in determining when and where tree trimming will be done:

1. Reports of electrical outages caused by trees.
2. Areas where trees have been damaged by storms.
3. During the regular tree-trimming cycle.
4. Periodic inspections by AUB personnel.
5. Reports from customers indicating potential tree/power-line problems.

Customers requesting tree-trimming services from AUB should contact **745-4501** and ask to speak to a Customer Service Representative.

#### **6.4.1 Customer Service Lines**

Trees around service drops (the lines running to the customer's house) are the customer's responsibility. For the customer's convenience and safety, AUB crews will lower those lines at the customer's request (Monday through Friday, barring holidays) so that the customer may remove or trim a tree near them.

#### **6.5 Customer Tree Trimming Practices**

Customers have the option of arranging for an independent contractor at their expense to trim their trees to AUB specifications prior to AUB contract crews trimming their neighborhood.

AUB will assist property owners and/or their commercial contractors, at their request, with the trimming and removal of trees that are near AUB electrical wires. An AUB representative will make an inspection and explain to the property owner or contractor what AUB can do to assist when a tree-trimming request is received. AUB's assistance may include one or both of the following activities:

1. The temporary rerouting, de-energizing or removal of electrical wires that may be hazardous to workers. AUB will coordinate with the property owner or contractor the time the work can be done.
2. The trimming of the tree so that it can be safely removed or trimmed by the property owner or contractor. All wood will be left on the property owner's premises. AUB is not responsible for cutting wood to size or piling brush. The customer or contractor will be responsible for removing brush that is blocking sidewalks or driveways.

Athens Utilities Board

<b>AUB Policies and Procedures Manual Standard Policies and Procedures</b>	
<b>Policy Number – AUB-04</b>	<b>Revision Number: 2</b>
<b>Subject Suspension of Nonpayment Disconnects in Times of Extreme Outdoor Temperatures</b>	<b>Effective Date: 06-25-2013</b>
	<b>Superintendent Approval:</b>
	<b>General Manager Approval:</b>

**1.0 PURPOSE**

The purpose of this policy is to provide AUB employees guidance on handling delinquent accounts scheduled for non-payment disconnect during times of temperature extremes.

**2.0 SCOPE**

This policy applies to all AUB employees. It will be particularly pertinent to utility service crews and their direct supervisors in the course of assembling, issuing and working the nonpayment disconnect list.

**3.0 GENERAL**

AUB has an established schedule that includes due dates and nonpayment disconnect dates. Following this prescribed schedule lowers the risk of financial losses by the utility and helps ensure fiscal responsibility and security for AUB ratepayers as a whole.

**4.0 DEFINITIONS**

**AUB** – means the Athens Utilities Board and its duly authorized employees, agents, and representatives.

**Board** – means the Chairman and all Commissioners but does not include any employees

**Customer** – Any person, business, or other entity that receives or has received utilities from Athens Utilities Board, any division.

**Disconnect list** – also called a “cutoff” list or “collections” list; this is a listing of accounts that have gone beyond the due date and any requisite waiting period without proper payment being made to the account to keep services active.

**5.0 PROCEDURE/POLICY**

**5.1 SUSPENSION OF THE NONPAYMENT DISCONNECT LIST AT TIMES OF EXTREME TEMPERATURE CONDITIONS**

AUB management checks weather conditions daily for the Athens area (zip code 37303) at [www.weather.com](http://www.weather.com). In the event that AUB has a nonpayment disconnect list for residential power or natural gas customers on a day when daytime temperatures are forecast not to exceed 32 degrees Fahrenheit or to be in excess of 98 degrees Fahrenheit, AUB management may suspend working the disconnect list on that day. Any residential accounts on the list that day will be placed on the next available cutoff list at such time that temperatures moderate sufficiently to allow the list to be worked normally. Extreme-weather service extensions shall not go beyond the period of extreme temperatures as outlined herein or the customer’s next due date, whichever comes first.

***Division of Accounting – Policies and Procedures  
Manual Standard Policies and Procedures  
Table of Contents***

AUB-05-01	Electronic Communication	18
AUB-05-02	Financial Accounting	22
AUB-05-03	Plant Accounting	26
AUB-05-04	Purchasing	28
AUB-05-05	Cashiers	32
AUB-05-06	Pay Agreements and Collections	37
AUB-05-07	Customer Deposits	42
AUB-05-08	Abandoned Property	45
AUB-05-09	Surplus Property	47
AUB-05-10	Utility Records	49
AUB-05-11	Debt Management Policy	52
AUB-05-12	Vehicle Purchases	69
AUB-05-13	FACTA	72

<b>Division of Accounting – Policies and Procedures</b> <b>Manual Standard Policies and Procedures</b>	
<b>Policy Number-AUB-05-01</b>	<b>Revision Number: 4</b>
<b>Subject:</b> <b>Electronic</b> <b>Communication</b> <b>Appropriate Use</b>	<b>Effective Date: 10-01-2009</b>
	<b>Superintendent Approval:</b>
	<b>General Manager Approval:</b>

## **1.0 PURPOSE**

Athens Utilities Board (AUB) recognizes the increase in technology resources available to employees designed to enable AUB to provide service in a more timely and efficient manner. Employees and contractors are expected to use any utility-owned electronic communications devices in a manner consistent with this policy.

## **2.0 SCOPE**

This policy applies to any and all use of electronic communication equipment by employees or approved contractors. Electronic communication devices include, but are not limited to, radios, telephones, cellular phones, faxes, all computer systems and peripherals, e-mail systems, internet and network resources.

## **3.0 ACCESS AND OWNERSHIP OF INFORMATION**

Electronic communications devices are provided to increase the efficiency with which AUB serves its customers. All information processed through or by any electronic communication device owned by AUB will be the property of AUB. All such information shall be subject to inspection at any time. AUB reserves the right to inspect any electronic communication or related device with no advance notice. Also, all electronic information will be made available to the Network Administrator in the event of absence, transfer, vacation or termination.

## **4.0 MONITORING**

AUB reserves to right to monitor electronic communications of its employees. E-mail may be a public record that is subject to public inspection. AUB shall comply with all federal laws relative to monitoring electronic communications.

## **5.0 PERSONAL USE**

Under no circumstances should AUB electronic communication equipment be used for political purposes or for employment outside AUB. Persons who are not employees of AUB, or approved contractors, should be permitted to use the utility's electronic communications equipment only in case of an emergency. Employees will reimburse AUB for any cost incurred for personal use of any electronic communication equipment.

## **6.0 INAPPROPRIATE USES**

Legal precedence has been established whereby employers may be held liable for their employees' inappropriate use of electronic communication devices. AUB will consider any inappropriate use of electronic communication equipment and systems as a serious offense. Inappropriate uses of electronic communication equipment include, but are not limited to:

- Activity violating AUB policy;
- Any use relative to outside employment, or using any AUB resources for personal gain;
- Disclosure of confidential information;
- Use for any political purposes;
- Use to store, transmit, load, view or download sexually explicit material and images, violent images and material, or any other material or language that may be offensive to others;
- Any use of harassing, intimidating, discriminating, or threatening language;
- Violations of federal copyright laws or software licensing agreements;
- Playing or installing any computer games;
- Activity violating any federal, state or local laws;
- Stealing, using, or disclosing someone else's user ID or password without authorization;
- Sending or posting messages that defame or slander other individuals;
- Refusing to cooperate with any security investigation;
- Political causes or activities, religious activities, or any type of gambling;
- Communicating personal views as representing those of the organization;
- Sending anonymous e-mail messages;

## **7.0 E-MAIL AND INTERNET**

E-mail and internet access are provided to improve productivity. These tools should be used predominantly for company business. Under no circumstance should any use of E-Mail or Internet, other than appropriate business use, result in any additional cost to AUB. Superintendents shall have the responsibility of determining which employees in their respective divisions will have E-Mail and Internet access. This decision will be based on business need only. Superintendents will advise the Network Administrator of all additions and deletions of access to these tools.

AUB reserves the right to monitor all e-mail and internet activity processed through its equipment. Any information processed through, or stored on, any of AUB's computer equipment is the property of AUB. Information transmitted via e-mail is not secure. Because of this fact, employees are prohibited from transferring any confidential information via e-mail.

## **8.0 PERSONAL COMPUTERS AND DATA SECURITY**

Because of the sensitive nature of certain systems within AUB, passwords may be assigned. Passwords are designed to protect systems from unauthorized access. Employees should not use such obvious passwords as a child's or spouse's name. Passwords should be a word or phrase that is not readily determinable. Employees should never share their password with other personnel, or record them in written form. Passwords should be committed to memory. Passwords should never be posted on a computer terminal, under the keyboard, or anywhere accessible to unauthorized users.

No software will be installed on any of the utility's computer equipment without the prior approval of the Network Administrator. Under no circumstances will pirated software be installed on any AUB computer equipment. Any software installed on AUB computers should be properly licensed to AUB. It is a violation of this policy to install any software that is licensed to anyone other than the utility on any AUB equipment. No files should be downloaded from the internet, or copied from any storage medium, without prior approval from the Network Administrator. It will be the responsibility of the Network Administrator to ensure that all virus protection software is updated at an appropriate frequency. All systems will be properly protected by virus detection software. In the event of a serious virus threat, the Network Administrator will have the authority to disable any systems.

Employees should not alter the hardware configuration of any systems. All hardware changes should be performed by the Network Administrator, or his/her designee. No components will be added to, or taken from, any systems without permission from the Network Administrator. Employees should exercise caution with food and drink around any electronic equipment. Persons who are not under the employ of AUB or contracted to provide service to AUB will not be permitted access to any AUB computer systems.

The viewing, altering, transmitting, accessing, copying, or deleting of files belonging to another employee without their prior consent is prohibited. However, the Network Administrator may delete certain files while performing regular maintenance procedures. Each individual user will be responsible for backing up data stored on the local drives of their respective systems. The Network Administrator will be responsible for backing up all data written to network systems. Copies of network backups will be stored offsite. These backup copies will be rotated at a regular frequency.

Division of Accounting – Policies and Procedures Manual Standard Policies and Procedures	
Policy Number – AUB-05-02	Revision Number: 3
Subject: Financial Accounting	Effective date 07-01-2010
	Superintendent Approval:
	General Manager Approval:

### **1.0 General Ledger Chart of Accounts**

A separate general ledger chart of accounts shall be maintained for each of Athens Utilities Board’s (AUB) divisions using the Uniform System of Accounts prescribed for electric utilities by the Federal Energy Regulatory Commission (FERC). Separate bank accounts shall be maintained for each of the division’s operating funds. Excess funds of each division may be commingled to obtain higher rates of return on certificates of deposit and money market account deposits. Subsidiary records will be maintained to account for each division’s ownership of all commingled funds.

### **2.0 Bill Payment**

All bills for expenses of AUB shall be properly approved by purchase order, or they shall bear approval of divisional management. Routine monthly expenditures (e.g. rent) require initial approval. Documentation of approval is not required for subsequent payments. Initial approval documentation of routine monthly expenditures will be maintained by accounting personnel. All bills shall be submitted to accounting for payment. Accounting personnel will verify and maintain approval documentation for all payments. Receipt of materials purchased will be substantiated by reviewing warehouse receipt documentation prior to expense payment. Expenditures for each division will be segregated and paid from separate operating accounts. Checks for each division’s operating account will require two signatures. These checks may be signed by any combination of the division’s Superintendent, the Superintendent of Accounting, the General Manager, or the Accountant II.

### **3.0 Excess Funds**

Each division’s funds in excess of those funds necessary for the day-to-day operation of the division shall be removed from the operating account (typically non-interest bearing accounts) and deposited in an interest bearing deposit account. Funds that will be needed in the near term shall be deposited in a money market deposit account that allows for withdrawal. These funds shall be “swept” in and out of this account as needs dictate. Funds from each division may be commingled in this account to improve interest earnings. This account shall be maintained at an FDIC insured financial institution, and the institution shall pledge acceptable investments from its investment portfolio to secure 105% of the uninsured balance of all deposits in that institution, or the institution will participate in the State of Tennessee Collateral Pool.

Funds that will not be needed in the near term may be deposited in savings accounts, certificates of deposit, short-term treasury bills and certificates, or deposits in the Tennessee Local Government Investment Pool. All deposits in financial institutions shall be maintained only at FDIC insured institutions. The depository institution shall



pledge acceptable investments from its portfolio to secure 105% of the uninsured balance of all funds on deposit, or the institution will participate in the State of Tennessee Collateral Pool.

#### **4.0 Budget/Finance Committee**

The Board of Directors shall appoint a three-member committee consisting of members of the Board of Directors to serve as the Budget/Finance Committee. These members shall serve one-year terms. The Superintendent of Accounting will serve as the liaison between management and the Budget/Finance Committee. It shall be the responsibility of this committee to review the monthly financial performance of each division and report this information to the full board. Furthermore, this committee shall approve the selection of the utility's auditor. It will review the results of the annual audit in detail and report to the full board. Management of AUB shall present the annual budget to the Budget/Finance committee for detail analysis and discussion. Once the committee approves the budget, it will be presented to the full board. All banking relationships shall be the responsibility of the Budget/Finance Committee upon the recommendation of the Superintendent of Accounting and the General Manager. The committee shall also review any and all other financial information as necessary.

#### **5.0 Budgeting**

Each division shall operate under its own unique budget. Budgets shall be prepared annually. They shall be approved first by the Budget/Finance Committee of the Board of Directors and then by the full board prior to commencement of the applicable fiscal year. Preparation and presentation of the annual budget for each division shall be the primary responsibility of the Superintendent of Accounting with input from the divisional superintendents. Each budget shall consist of a financial performance budget and a capital budget. The total annual budget for each division shall be listed by general ledger account. This information will be presented in the form of a budget worksheet. The total of each category of income and expense as enumerated on the budget worksheets shall flow into the financial performance budget. The divisional capital budgets shall provide information relative to each division's planned capitalized expenditures for the fiscal year. These budgets shall provide cash flow information before and after the planned expenditures. Expenditures to be financed by borrowed funds shall be reported separately.

#### **6.0 Financial Reporting**

Preparation of the monthly financial statements for each division shall be the responsibility of the Superintendent of Accounting. These statements shall consist of at least the monthly balance sheet, income statement and cash flow statement for each division. These statements shall contain sufficient comparative data from prior periods to gauge the current period's financial performance for each division. The Superintendent of Accounting shall present each division's financial statement to the Budget/Finance

Committee each month and then to the full Board of Directors. Other financial information may be reported as deemed appropriate. Monthly financial statements will provide information comparing actual performance to the monthly and annual budgets. All statements will be prepared using Generally Accepted Accounting Principles (GAAP).

**7.0 Audit**

An independent certified public accountant shall be employed by the board to make such audits and reports as the board may deem necessary. The selected accountant shall perform a comprehensive audit of each division’s financial records at least annually. The selection of the accountant shall be performed by competitive bid. The board shall select the best bid upon management recommendation. The selected auditor shall be approved by the City Council of the City of Athens Tennessee. The selection of the utility’s auditor may be coordinated with that of the City of Athens, but is not required to be. Results of all work performed by the selected accountant shall be first reported to the Budget/Finance Committee and then to the full board.

**8.0 Banking**

It is the policy of the AUB to make every effort {within legal authority} to patronize local businesses. Banking relationships will be maintained with local financial institutions when possible. Local financial institutions are those institutions that are owned and operated by individuals or holding companies located in McMinn County. The depository financial institutions into which deposits are placed shall pledge acceptable securities from its investment portfolio to secure 105% of the uninsured total at all times, or the financial institution will participate in the state of Tennessee Collateral Pool. Funds of AUB will be deposited only in financial institutions insured by the FDIC. The Superintendent of Accounting may review the financial performance of any financial institution accepting AUB deposits as deemed appropriate. Unacceptable financial performance as revealed by this review may be grounds to terminate any deposit relationship.

**9.0 Travel and Related Expenses**

Travel reimbursement will be divided into three categories to address the diverse needs of the AUB Board and staff.

<b>Employee Classification</b>	<b>Applicable Re-imbusement Policy</b>
Board Members	Actual and Reasonable
Management/Salaried	\$50 Per-diem or Actual and Reasonable

Hourly

\$50 Per-diem

It is the intent of AUB to ensure that all expenses are covered for Board Members on company related business travel. Board members may fill out appropriate forms for cash advances and must turn in receipts for meals. Gratuities may be itemized without the need for receipts. Receipts should be provided for lodging, rental cars, meals, and associated incidental items (such as airport parking).

Management and salaried personnel have the flexibility to choose between actual and reasonable reimbursement dependent upon the nature of the business trip. The individual must use their own discretion upon making this choice dependent upon location and whether they are traveling with board members. Employees electing to take actual and reasonable are entitled to cash advances from AUB.

Hourly employees traveling on business related matters shall be entitled to advances totaling \$50.00 for each day of travel.

### **General**

Travel related expenses must be approved by the appropriate superintendent, or the General Manager, prior to presentation for reimbursement or advance. Advances for travel must be submitted at least five business days prior to the date the advance will be needed. Advances should only include the anticipated per diem amount. Expense reports must be properly completed and approved before any travel related expenses (above advances for per diem) will be paid. The travel expense report must be accompanied by all receipts for incidental expenditures. Per diems cover the daily cost of meals. The cost of meals should not be included on the travel expense report. Employees should attempt to use company automobiles for business travel. The cost of the use of personal automobiles will be reimbursed to employees at the IRS statutory mileage rate when company automobiles are not available. The traveling employee will submit a log of all business miles driven in a personal automobile for reimbursement. This log will disclose beginning mileage, ending mileage and the total miles driven for business purposes. The log must be signed by the traveling employee and the appropriate superintendent (or the General Manager) before reimbursement will be made. Employees traveling in company automobiles will be reimbursed for purchases of fuel on personal credit cards or cash. These amounts should be included on the traveling employee's travel expense report with receipts attached. Failure to attach receipts will negate the availability of reimbursement. AUB will pay all costs associated with travel on common carrier for business travel. The Director of Management Services should make these travel arrangements. These costs will be paid by company credit card and should be included on the employee's travel expense report to properly account for all expenses

associated with the specific trip. All lodging expenses associated with approved business travel will be paid by AUB. These must be evidenced by original receipts and included with the employee's travel expense report. Every effort should be made to pay lodging expenses with a company credit card, but employees will be reimbursed for proper lodging expenses paid by personal credit card or cash when properly approved and documented on the travel expense report. Documentation must include the original receipt. AUB will not reimburse traveling employees for personal expenses such as in room movies or mini-bar charges. AUB will not reimburse for alcoholic beverages purchased on business trips. Employees will not be reimbursed for travel expense of the employee's spouse, with the exception of lodging. Traveling employees will reimburse AUB for any of their spouse's expenses (lodging excluded) charged on a company credit card. All documentation relative to travel expenses shall be submitted to accounting within five business days of the employee's return.

Division of Accounting – Policies and Procedures Manual Standard Policies and Procedures	
Policy Number – AUB-05-03	Revision Number: 4
Subject: Plant Accounting	Effective Date: 10-01-2009
	Superintendent Approval:
	General Manager Approval:

### **1.0 Purpose**

Plant accounting at Athens Utilities Board (AUB) will be performed in compliance with methods and procedures prescribed in the Uniform System of Accounts by the Federal Energy Regulatory Commission (FERC). Plant accounting for each division of the AUB will be centralized under the supervision of the Superintendent of Accounting.

### **2.0 Fixed Assets**

Plant accounting personnel will maintain records of all fixed assets for each division. This information shall include, but not be limited to, cost, periodic depreciation, accumulated depreciation, book value, useful life, and salvage value. As a general rule, all fixed assets with an original purchase value of \$1,000.00 or more will be capitalized on the books of the appropriate division, and depreciation will be recognized over the useful life of the asset as prescribed by the Uniform System of Accounts and Generally Accepted Accounting Principals (GAAP). All assets purchased with an initial cost under \$1,000.00 shall be expensed to the appropriate division’s books during the period in which the asset is purchased.

### **3.0 Construction in Progress**

Plant accounting shall maintain all records pertaining to construction in progress for each of the divisions of AUB. Furthermore, they will maintain records pertaining to work orders and work order completion. Plant accounting will be responsible to close all projects out of construction in progress as soon as practicable upon completion of the project. Every effort shall be made to close the project out of construction in progress in the same month that the project is completed. Projects will not be allowed to remain in construction in progress beyond the fiscal year in which the project is completed.

### **4.0 Annual Inventory**

An inventory of all materials and supplies will be conducted annually. This inventory will be supervised by plant accounting personnel in conjunction with the Warehouse Supervisor. Plant accounting personnel will update the books of each division to reflect losses or gains not previously recognized but identified as a result of the inventory. Adjustments must be approved by the Superintendent of Accounting. The annual inventory will be conducted prior to the end of the fiscal year.

### **5.0 In Lieu of Taxes**

The Power and Gas divisions of AUB will pay “in lieu of tax payments” to each of the taxing jurisdictions in which it maintains investments in physical plant. The calculation of these payments shall be the responsibility of plant accounting personnel. These calculations shall be performed in compliance with the “Municipal Electric System Tax

Equivalent Law of 1987” [TCA Title 7, Chapter 52, Part 3]. The amounts due the various taxing jurisdictions shall be calculated annually. These calculations shall be reviewed and approved by the Superintendent of Accounting. In lieu of tax payments shall be paid to the various taxing jurisdictions monthly.

Division of Accounting – Policies and Procedures Manual Standard Policies and Procedures	
Policy Number – AUB-05-04	Revision Number: 4
Subject: Purchasing	Effective Date: 10-01-2009
	Superintendent Approval:
	General Manager Approval:

Purchasing for Athens Utilities Board (AUB) shall be centralized under the supervision of the Superintendent of Accounting. A purchasing manager shall be employed whose responsibility includes purchasing materials and supplies for all divisions. The purchasing manager’s responsibilities shall also include maintenance of building and grounds at the utility’s main office and stocks of office supplies.

o **Competitive Bidding**

All major purchases (\$10,000.00 or more) for each division shall be performed by the purchasing manager by using a competitive bidding process. Divisional Superintendents will provide the Purchasing Manager specifications detailing needs after approved by the General Manager. The Purchasing Manager will solicit bids based on the specifications supplied. These bids may be solicited by telephone, in writing, or by newspaper or radio advertisement. Bids will be accepted from appropriate vendors, and the Purchasing Manager will select the most appropriate bid to recommend to the requesting Superintendent. All bids will be in writing and supplied in sealed envelopes. AUB will decide which bid to accept after the bid submission deadline. Any bids submitted after the deadline will be rejected. AUB reserves the right to reject all bids. The winner of the bid shall be the lowest qualified and responsible bidder. AUB may consider the following factors in addition to the price quoted in determining the lowest qualified and responsible bidder:

- Apparent ability to perform;
- Quality of the company, product or service;
- Purpose or use of the product or service;
- Discount for prompt payment provided by the vendor;
- Freight method and cost;
- Delivery date;
- Past performance;
- Other pertinent factors such as experience in providing products or services to similar utilities, references on similar jobs, and compatibility with existing utility equipment.

AUB is not obligated to purchase a product or service from the bidder with the lowest price. All major purchase bids will be presented to, and approved by, the Board of Directors. Upon board approval, the purchase will be completed by the Purchasing Manager. When a bid is accepted and approved by the Board of Directors, AUB will notify the vendor in writing of its acceptance.

○ **Purchases not Requiring Competitive Bids**

The following purchases **do not** require competitive bids:

- Items or groups of items costing less than \$10,000.00;
- Contracts to provide a continuous work force through independent contractors for the maintenance, installation and repair of the system;
- Purchase of goods or services for which there is a single source of supply;
- Purchases for immediate delivery in actual emergencies arising from unforeseen causes;
- Purchases of real property (permanent, immovable property such as land, buildings and improvements);
- Purchases from any federal, state or local government unit or agency;
- Purchases of items for resale;
- Contracts for professional services as set forth in [TCA 12-4-106];
  - Legal services;
  - Fiscal agent;
  - Financial advisor or advisory services;
  - Similar services by professional persons or groups of high ethical standards;
  - Engineering services;
  - Architectural services;
  - Accounting services;

○ **Bid and Performance Bonds**

AUB may require vendors to submit a bid bond with their bids under the following guidelines:

- The bid bond must be issued by a surety company licensed to do business in the State of Tennessee;
- Bid bonds submitted by unsuccessful vendors will be returned upon award to contract;
- Personal or vendor company checks are not acceptable in lieu of bid bonds; however, bank cashier's checks will be accepted.

AUB may require vendors to submit a performance bond under the following guidelines:

- A performance bond must be issued by a surety company licensed to do business in the State of Tennessee;
- When required, the amount of the bond will be stated by AUB in writing;
- The vendor must file a performance bond with AUB within ten working days after receipt of the request for bid;
- Personal or vendor company checks are not acceptable in the place of performance bonds; however, bank cashier's checks will be accepted;
- An irrevocable letter of credit from a state or national bank or state or federal savings and loan association having its principal office in Tennessee may be acceptable in lieu of a performance bond. The terms and conditions of the letter of credit are subject to the approval of AUB.



○ **File for Competitive bids**

When a purchase requires competitive bidding, the purchasing manager shall create a file for this purchase transaction which shall include the following:

- Written requests for bids;
- Written notation of bid deadlines that AUB requests by telephone;
- Written bids received from vendors;
- Any vendor’s written confirmation of telephone bids;
- All written contracts that relate to competitive bids;
- Other related written materials;
- If a bid is awarded to someone other than the lowest bidder, a memo shall be placed in the file stating the reason the winning vendor was selected over the low bidder. The purchasing manager shall be responsible for placing this information in the file.

**3.0 Purchase Orders**

AUB uses a purchase order system. All major purchases require the signature of the Purchasing Manager on a long-form purchase order. These will be submitted to accounting prior to payment for the purchase. The Purchasing Manager shall issue “local purchase order” books to each of the divisions. Local purchase orders may be used by field personnel for small purchases of needed items in the field. Local purchase orders shall be pre-numbered forms identifiable by division. These will be three part forms. One copy of each local purchase order shall be submitted to accounting to substantiate the purchase upon receipt of the vendor’s bill. The original will be submitted to the vendor, and one copy shall be retained in the purchase order book. Accounting copies of local purchase orders must be submitted to accounting on the day the purchase order is executed.

**4.0 Materials and Supplies**

The purchasing manager and/or the Warehouse Manager shall be responsible for purchasing inventories of materials and supplies for all divisions. These supplies shall be purchased based on requisitions made by Warehouse personnel or specific divisional Superintendents. Large purchases shall be completed using the bidding process previously described, but the Purchasing Manager shall research and obtain the best price for all purchases under the bidding threshold.

**5.0 Record Retention**

The following shall be the record retention requirements for records relative to the purchasing function. It shall be the responsibility of the Purchasing Manager to maintain all purchasing and bidding records:

- |                       |             |
|-----------------------|-------------|
| a) Correspondence     | Two years   |
| b) Bank deposit slips | Three years |
| c) Inventory Records  | Three years |
| d) Invoices           | Three years |

➤ Purchase orders	Three years
➤ Contracts	Six years
➤ Leases	Six years
➤ Insurance policies	Six years
➤ Deed and other title documents	Six years after retirement
➤ Fixed asset records	Fifty years

## **6.0 Omissions and Exceptions**

In the absence of specific rules or policies, the disposition of purchasing procedures shall be made by the Board of Directors in accordance with its usual and customary practices. Any exception to the purchasing policy must be approved by the appropriate divisional Superintendent and the General Manager. Under no circumstances will any policy exceptions that violate any state, federal, or local statute be approved.

<b>Division of Accounting – Policies and Procedures Manual</b> <b>Standard Policies and Procedures</b>	
Policy Number: AUB-05-05	Revision Number: 3
Subject: Cashiers, Payment Acceptance, Check Cashing, and Employee Payments	Effective Date:
	Superintendent Approval:
	General Manager Approval:

**1.0 Purpose**

Athens Utilities Board (AUB) provides cashier service for the convenience of its customers. Customers shall be served at the counter in the lobby of the utility’s main office, and via a drive-through window. After-hours service is provided via an after hours-depository. The counter and drive-through service shall be provided from 7:30 a.m. until 5:00 p.m. Monday through Thursday. These services will be provided from 7:30 a.m. through 4:00 p.m. on Fridays. Night depository service is available for the convenience of the utility’s customers at all times.

**2.0 Reconciliation**

Currency supplies for use in the drive through facility shall be maintained separate from the supplies used at the inside counter. Both funds shall be reconciled at least once each business day. The reconciliation process will consider all amounts received in currency and checks during the business day. The ending currency supply shall be reconciled to the “packet control total” generated in the course of each day’s transactions.

**3.0 Currency Access**

The area behind the cashier counter shall be secured at all times during the business day. Only authorized personnel will be permitted behind the counter. The lobby area at the counter is intended to be a customer service area. Employees will not loiter in the lobby area. Outside visitors behind the counter will not be permitted, and visitors at the counter should be discouraged.

o **Petty Cash**

Petty cash and working funds will be established by withdrawals from the general fund and kept under general ledger control. Petty cash funds are established for the purpose of convenience when it is not feasible to pay for incidentals and small items by check or local purchase order. Local purchase orders should be used in all cases where monthly billing is, or can be made, to AUB. Working funds are established for the sole purpose of receiving money and making change for payment of utility bills. There shall be only one petty cash fund under the sole responsibility of one cashier who reports directly to the Superintendent of Accounting. Petty cash fund shall be reconciled daily, and responsibility for this reconciliation shall be rotated among different cashiers at least once each week.

o **Petty Cash Disbursements**

A formal cash voucher must be completed in ink and approved by a superintendent before any disbursement is made from the fund. A separate voucher shall be used for

each disbursement from the fund and supporting data such as receipts, invoices, freight bills, etc., should be used supplementary to, and not in lieu of, the voucher. Supporting data shall be attached to the voucher. Checks will not be cashed out of petty cash.

○ **Reimbursement to Petty Cash**

Petty cash will be reimbursed as frequently as the fund requires, but always at the close of each monthly accounting period. Reimbursement will be made by check on the general fund to the custodian for amounts paid out of the petty cash fund. The petty cash custodian will present a “schedule of disbursements” with all cash vouchers and related documentation to substantiate amounts to be reimbursed. Reimbursement checks shall always be in the exact amount of the disbursements made from the petty cash fund.

**5.0 Night Deposit**

AUB provides a night depository for the convenience of its customers. The depository safe will remain closed and locked at all times. Cashiers will open the depository safe each morning prior to 7:30 under dual control. All payments in the depository will be processed and posted to the customers’ accounts. The depository safe will be opened again at 7:30 a.m., and any additional payments received will be processed. Any payments made in the night depository after 7:30 a.m. will be processed the following business day. Penalties for payments received in the night depository that were due the prior day will be forgiven. These payments will be processed as though they were received on their due date. All night depository envelopes will be retained for documentation. Cashiers will record the appropriate account number, customer name, and amount received on the face of the night deposit envelopes.

**6.0 Mail Receipts**

Customer payments received via mail will be processed by the cashiers daily. They will be processed on the date received, however the post date placed on the envelope by the postal service will determine whether late payment penalties will be assessed. Payments in envelopes bearing post dates on or before the due date will be assessed no late payment penalties. Late payments with post dates after the due date will be assessed the appropriate penalty. Cashiers will retain the portion of the envelope containing the post date and return address for all late payments received in regular mail when the customer has not included the penalty amount in the payment. This portion of the envelope will be attached to the corresponding payment stub.

**7.0 Employee Utility Payments**

AUB expects its employees to be above reproach. Employees are expected to pay their utility bills on or before the due date. Under no circumstances will late payment penalties be waived for any employees when they would not ordinarily be waived for other

customers. Any employee payment received prior to 7:30 a.m. will be processed as though it was received in the night depository, and late payment penalties may be waived if the payment was due the day before. All payments paid at the counter, or in the drive through, after 7:30 a.m. will be processed on the date received, and appropriate late payment penalties will be applied. Cashiers will not process their own personal transactions. These transactions should be processed by another cashier.

## **8.0 Returned Checks**

As a matter of practice, AUB will accept personal checks for utility payments. The utility will process all checks on the date received, and under no circumstances will it accept post-dated checks. All customers having checks returned to AUB will be assessed a fee of \$20.00. This fee will be added to the customer's utility account. Cashiers will advise customers via telephone or personal contact that a check has been returned and that the fee has been added to their balance due the utility. Utility service may be interrupted at any time if the customer fails to pick up the check and pay all requisite charges and fees in cash. AUB will not accept checks in payment of utility bills for customers with two checks returned.

## **9.0 Credit Cards**

For the convenience of its customers, AUB accepts certain credit cards. Master Card, Visa, and Discover cards will be accepted. Customers may present the cards for payment of utility bills in person or call AUB and provide their credit card information via phone to make payment during normal business hours. A link for on-line credit card payment is also available on the AUB web page at [www.aub.org](http://www.aub.org). Credit cards may only be used to pay for utility service. Cash advances will not be allowed for any customers or employees.

### **9.1 Budget Bill**

Athens Utilities Board provides a Budget Billing system whereby customers can pay an equal amount each month. The customer must have been at their current residence for at least twelve months to qualify for budget billing, as the monthly bill amount is set by averaging the most recent twelve months' usage history. The annual budget billing period commences on July 1 and ends on June 30. Equal payments paid throughout the budget billing year are accumulated as the Budget Billing Balance. This amount can be compared to the actual amount used at any time during the year to arrive at the year-to-date difference. As of June 30 each year, this difference is calculated. Any deficiency between budget payments paid and actual used of \$50.00 or more is included on the June utility bill, and customers are required to pay the difference. The utility will pay the customer for any overage between the budget bill payments and actual utility service used as of June 30 each year. Customers may request that the utility leave any credit balance (overage between budget and actual) on their account to continue into the next

budget bill year. Any difference under \$50.00 (deficiency or overage) will be applied to the utility account. Once all deficiencies and overages are settled at the end the budget billing year (June 30), the monthly budget bill payment amount is recalculated using the most recent twelve months usage history. The set monthly budget bill amount must be paid each month. Failure to do so will result in delinquent account status regardless of the account's actual balance and may result in service disconnection. Budget bill customers may elect to pay more than the set monthly budget bill amount. Any amount paid over the budget amount will be applied to the account balance. Customers may elect to discontinue budget billing at any time. Any deficiency between the total of budget payments paid and actual usage since July 1 of the current budget bill year must be satisfied to discontinue budget billing. Any excess budget bill payments over actual usage will be applied to the utility account upon discontinuance from budget billing. Budget bill accounts stay in the budget bill system until the customer requests removal.

#### **10.0 Automatic Bank Draft**

AUB will accept bank drafts on any commercial bank. The customer must complete and sign a preauthorization form and attach a voided check for the account from which the payment is to be made. AUB will mail a bill to the customer with a message indicating that the payment has been automatically deducted from the customer's checking account. These bills are mailed approximately fifteen days prior to the payment processing date providing the customer opportunity to review the bill before the payment is drafted. The customer's draft will be presented to the bank for payment on the date the "Net" amount is due. If funds are not available in the account at the time the draft is presented and the draft is returned unpaid, AUB will notify the customer by mail, phone or personal contact that the draft was returned unpaid. Upon return of the draft, an additional charge of \$20.00 will be added to the customer's utility account. The customer account will be subject to forfeiture of the discount and/or the adding of any penalties due and subject to the utility's cut-off policy. Any customer whose draft is returned unpaid twice will be removed from the bank draft program. Customers wishing to revert to regular payment options may do so at any time by calling AUB and requesting to be removed from the bank draft program. Upon receipt of this request, the customer will be removed from the program at the next available billing cycle.

#### **11.0 Check Cashing**

AUB will not cash checks as a matter of practice. All checks accepted by cashiers must be made payable to AUB. These instruments must be for the amount the customer wishes to pay. Checks may be made for more than the amount due, but the entire amount of the check must be applied to the customer's account. "Cash back" transactions will not be processed. AUB will not accept any third-party checks. These instruments will not be accepted for cash or for payment of utility bills. Customers with third-party

checks will be advised to have the instrument negotiated at their bank. Employees of AUB may cash a total of \$100.00 in checks during a business day. Cashiers will only accept personal checks made payable to AUB from employees. Third-party checks will not be cashed. The only exception to the third party check exclusion mentioned above is checks made payable to an employee by the Athens Utilities Board Employees' Credit Union. The \$100.00 limit applies to credit union checks.

### **12.0 Record Retention**

All records related to customer billing and payments will be maintained for at least five years.

Division of Accounting – Policies and Procedures Manual Standard Policies and Procedures	
Policy Number: AUB-05-06	Revision Number: 6
Subject: Pay Agreements and Collections	Effective Date: 01/29/2014
	Superintendent Approval:
	General Manager Approval:

**1.0 Purpose**

In order to protect the rate payers of Athens Utilities Board (AUB), standard collection policies must be followed consistently. While AUB is a non-profit entity, it must protect its financial integrity in order to maintain rates as low as possible. Because of the nature of the utility industry, all customers in our service area must be serviced. This fact requires that collection efforts be diligently administered on a daily basis.

**2.0 Collectors**

Sufficient staff will be maintained to administer the collection process. This will consist of at least two outside collectors (at most times) and sufficient internal support personnel to provide information to the outside collection personnel. Outside collections will usually be performed by a minimum of two employees. Employees will never be expected to place themselves in dangerous situations. In the event that a collector feels unsafe, he should remove himself from the situation and advise management.

**3.0 Daily Collections**

Listings of delinquent accounts will be generated by collections support personnel daily. This list will not be generated until all night depository and mail receipts have been processed.

**4.0 Pay Agreements**

From time to time customers may experience financial difficulties rendering them unable to pay the entire amount due for their utility service. This situation may be especially aggravated during the winter months. AUB provides pay agreements as a mechanism to assist these customers in satisfying their obligation. Requests for pay agreements will be taken by Customer Service Representatives (CSR). Upon payment of 50% of the past due amount, the customer may be granted an additional five business days beyond the scheduled cut-off date to satisfy the remaining balance. Extension dates are prescribed by a schedule that each Customer Service Representative has. The Superintendent of Accounting, or Assistant General Manager may approve extensions up to ten days beyond the scheduled cut-off date. Any extensions beyond ten business days will be considered an exception to this policy and must be approved by the Assistant General Manager or General Manager. CSR's will complete a pay agreement form for all extensions granted, and customers will be required to initial each of the provisions on the form. They will be required to provide picture identification and sign the pay agreement document acknowledging their agreement with its provisions. Failure to honor the terms of a pay agreement may disqualify the customer's eligibility for future pay agreements. Pay agreement forms will be forwarded to collections personnel where they will be maintained. Customers whose accounts have been disconnected for nonpayment will be allowed to execute a pay agreement only upon approval of the Superintendent of Accounting,



Assistant General Manager or the General Manager. Collections personnel will maintain all records pertaining to pay agreements. These will be organized by due date as identified on the pay agreement form. Field collection personnel will disconnect service for customers' failure to honor the covenants of pay agreements. Collections personnel will maintain records identifying customers that have failed to honor pay agreements. From this information, a listing of customers ineligible for future pay agreements will be prepared and forwarded to all CSRs. Collections personnel will add notes to customers' accounts identifying them as ineligible for future pay agreements.

## **5.0 Collections**

Collections personnel will generate a listing of all past due accounts each day. From this information, a list of all accounts in disconnect status will be prepared. Accounts appearing on the disconnect list for the first or second time may not be disconnected. Field collection personnel will leave a reminder for these customers advising that their utility payment is in arrears. Service for these accounts may be disconnected approximately one week after the reminder has been left. Service for accounts appearing on the list three or more times may be disconnected. Meters that have been disconnected for nonpayment will be identified by a red meter seal. Field collection personnel may use discretion as to whether or not a particular account is disconnected. Field collection personnel will communicate decisions to internal collections personnel so the decisions can be properly documented. Pay agreements are not available to customers once service has been disconnected for nonpayment unless approved by the General Manager, Assistant General Manager or the Superintendent of Accounting. Field collections personnel will report each day's activities to the collection department. Collection personnel will prepare a listing of all accounts that have been disconnected for non-payment prior to the close of business each day. This information will be provided to after-hours personnel.

Field personnel may accept payment for past due utility accounts when reconnecting a customer after hours and also when servicemen arrive at a location during business hours to perform a non-payment disconnect. After hours reconnects will be subject to a reconnect fee as outlined in section 6.0 below. If a customer wants to pay a serviceman to avoid a disconnect after the serviceman has made the trip to the customer location for the purpose of disconnecting the service for non-payment, the customer must pay the full past-due amount and an additional \$15.00 (Fifteen dollar) trip charge. Otherwise, the serviceman's job is to perform the disconnect before leaving the location. The charge is designed to help defray the cost of the collection trip to the location, which was necessitated by non-payment on the account and which otherwise would be borne by the ratepayer base at large.

Field personnel will consistently provide receipts for all amounts collected. These receipts will be a three-part form. The original will be given to the customer at the time the payment is accepted, the second copy will be given to the cashiers when funds are submitted, and the third will be retained by the field personnel accepting the payment.

## **6.0 Reconnections**

Once a service has been disconnected for nonpayment, the entire amount due plus a reconnect fee must be satisfied before the service may be reconnected. Customers paying a utility bill for disconnected accounts may have service reconnected in the current

business day. The fee to have service reconnected in the current business day is \$50.00. The fee for customers agreeing to wait until the following business day to have the service reconnected is \$15.00. Every effort will be made to have these services reconnected as early as possible. The fee for all reconnections between the hours of 5:00 p.m. and 10:00 p.m. will be \$130.00. There will be no reconnections after 10:00 pm., on weekends or on holidays. These reconnection fees may be waived only with the approval of the General Manager, Assistant General Manager or the Superintendent of Accounting.

## **7.0 Unauthorized Service Restoration and Meter Tampering**

AUB will consider the unauthorized restoration of service by any person to be a serious offense. Unauthorized persons will not tamper with, remove, reconnect or disconnect any meter, service connection, or any device attached to any meter or service connection. Tampering with any of these items will result in a \$500.00 fee per occurrence and may result in prosecution. This fee applies to water and gas connections as well as power. Cutting a meter seal is considered meter tampering. Any AUB personnel observing evidence of meter tampering will report the tampering to the collection department. Once the tampering has been verified, the service will be disconnected by removing the meter from the meter base and replacing it with a glass cover, whether the account is current or past due. The meter tampering fee, any past due balance and the appropriate reconnect fee must be paid before the service may be reconnected.

### **o Discontinuance of Service**

AUB reserves the right to discontinue service to any residence or business within its service for any of the following reasons:

- Nonpayment of any bill or any other charges;
- Partial payment of bill or other charges not specifically identified by payment agreement;
- Failure to comply with utility rules, regulations or policies;
- Any threat to public health on the customer's premises which may endanger other persons;
- Tampering with utility equipment or unauthorized use of service;
- In the event that a customer has allowed more than one service per meter.

For the benefit of the customer, normal service cut-offs will generally not be made on a Friday or on the day immediately preceding a holiday. In the following situations the utility reserves the right to discontinue service without customer notice:

- When in the opinion of the Manager a situation exists that may endanger public;
- Where there is evidence of tampering with utility equipment or stealing of service;
- Where it is discovered that a misrepresentation of identity was made in obtaining service.

Utility bills are recurring charges. Failure by the customer to receive a utility bill will not entitle the customer to be relieved of payment. Discontinuance of service by the utility shall not release the customer from liability for payment for service already received or from liability from payments that thereafter become due under the minimum bill provisions or other provisions of the customer's contract. AUB shall not be liable for any

loss or damage resulting from the discontinuance of service. A landlord shall not use the discontinuance of service to his or her property to force a tenant or occupant to surrender possession of the property.

### **9.0 Final Notice**

AUB's monthly billing statement to customers contains all of the legally required language to serve as a single notice to pay, including a date certain for payment and the customer's rights and remedies for disputing bills. As a courtesy to the customer and pursuant to TVA regulatory oversight, AUB also provides separate, final notification of the need to pay to avoid service interruption. In the event the due date passes and no payment is made a dated, written notice is generated and mailed to the customer's mailing address on record notifying the customer that no payment has been received at AUB, reminding the customer of the need to pay, and providing the time frame in which the account will be disconnected in the event of nonpayment. The notice's language reads:

*Dear Customer: As of today, we have not received your payment for last month's utilities usage. Perhaps you have misplaced your bill or making the payment has slipped your mind. If you have paid the amount in question prior to receiving this, please accept our thanks and disregard this notice. However, if we have not received the payment in full within five (5) days of the date shown above, we may have to disconnect your service. If that happens, we will need full payment plus a reconnect fee before reinstating your service. We don't want to see your service interrupted. If you have any questions or need to verify this payment with AUB, please call us at (423) 745-4501.*

### **10.0 Disputed Bills**

When a customer considers the bill to be incorrect, the customer may request a review of the bill. To request a review, the customer may contact any Customer Service Representative in person within five days after the date of the final notice. The customer's service will not be discontinued for failure to pay a disputed bill until the investigation of the customer's complaint has been completed. The Customer Service Representative taking the dispute request will advise the appropriate member of the AUB management team of the customer complaint so that a determination can be made regarding the need for an appropriate adjustment. All customer bill complaints will be resolved, and the customer advised of the outcome of the investigation, within five business days of receipt of the complaint. If the investigation reveals that the customer's complaint is invalid, the customer will be allowed five days from the date they are advised of the outcome of the investigation to pay the total amount due. A first class mailing to the customer's last known address constitutes notification. After that time, service may be interrupted. CSRs will inform customers of the steps that will be taken and when the customer should expect the dispute to be resolved when the review request is taken. They will also advise customers that the bill should be paid in full within five days after the dispute has been resolved. Customers may take the dispute to the utility's Board of Directors if they feel management has not adequately resolved the dispute. The customer must provide written notice to the General Manager of his/her intent to have the dispute heard by the Board of Directors. Such request will not delay discontinuance of service.

### **11.0 Customers' Responsibility**

The customers whose names appear on the application for service are the customers

responsible for payment of all charges. These customers are also responsible for any rules or policy violations that occur regarding the utility service to that property. Personal participation by the customer in any such violation shall not be necessary to impose personal responsibility on the customer. In the event any customer fails to pay any utility fee or charge, the customer shall pay all costs of collection including court costs and reasonable attorney's fees incurred by AUB in collecting such sums.

### **12.0 Refusal of Service**

AUB reserves the right to refuse to render service to an applicant or to any member of an applicant's household who is living at the same address whenever such persons are delinquent on any payment to AUB or had his or her service discontinued because of a violation of the regulations or policies of AUB. This service will be refused until all amounts owed to AUB are paid in full. Upon payment of all amounts owed, service will be rendered.

### **13.0 Customers not Subject to Discontinuance of Service**

AUB shall only disconnect the service to any customer on a life support system or dialysis machine in accordance with this policy. It is the responsibility of the customer to notify AUB if service discontinuance is life threatening. This notification must be accompanied by written acknowledgement of appropriate health care providers that the customer is dependent on life support. After notification, AUB will flag the customer's account as an "Emergency Medical Service" to ensure that the service is not cut off. If an emergency medical service customer cannot pay a bill or other charge, it shall be the customer's responsibility to find a social service agency or charitable group to assist the customers to prevent the eventual discontinuance of service for payment. Service for emergency medical service accounts will be provided a thirty-day notice once a utility bill has become delinquent. The service will be disconnected for nonpayment after the thirty days have lapsed. However, personal contact with the customer must be made before the service may be disconnected.

### **14.0 Service Termination at the Customer's Request**

The customer in whose name the service is furnished may request termination of service by mail, in person at the AUB office or by phone. Each customer must give a minimum of seven days notice to AUB of service termination. The customer will be responsible for all charges which accrue to the end of the seven-day period. Mail requests must be signed by the customer in whose name the service was provided. Customers requesting disconnection in person must provide identification unless the employee accepting the request knows the individual making the request. Employees accepting telephone requests for service discontinuation should make every applicable effort to determine the identity of the person making the request. At the time the request for termination of service is made, the customer must provide a forwarding address.

### **15.0 Record Retention Requirements**

All records regarding collections, discontinuance of service and reconnections shall be maintained for a minimum of ten years.

Division of Accounting – Policies and Procedures Manual Standard Policies and Procedures	
Policy Number: AUB-05-07	Revision Number: 6
Subject: Customer Deposits	Effective Date: 11/01/2015
	General Manager Approval:
	Superintendent Approval:

## 1.0 PURPOSE

To maintain a reasonably low rate structure for its services, Athens Utilities Board (AUB) must charge deposits for services based on the loss risk of applicants. Deposits provide security for the utility’s ratepayers in the event customers unexpectedly leave a service address or abandon an account and fail to pay the final utility bill(s).

## 2.0 POLICY

Applicants for utility service shall complete AUB’s customer application or contract. In the case of renters, AUB requires all adults named on the lease/rent receipt to sign as AUB account holders on the subject account. From the information provided, a Customer Service Representative will determine the customer’s classification, such as residential or commercial. Each classification has associated deposit amounts when applicable. Deposits are charged based on a credit score obtained from the major Credit Reporting Agencies via a service called Online Utility Exchange. In the case of multiple account holders a credit check will be processed on each applicant and the deposit determination will be based on the highest risk applicant.

## 3.0 APPLICABLE CUSTOMERS

### Residential

All applicants for AUB service are subject to pay applicable deposits at signup before services can be initiated. Deposits will be waived for residential customers who have had service with AUB within the past 24 months and had an acceptable payment history for the most recent 12 months, or for those whose credit rating qualifies them for a deposit waiver as outlined in section 4.0 below.

### Commercial

All applicants for AUB service are subject to pay applicable deposits at signup before services can be initiated. Deposits will be waived for commercial customers that supply an irrevocable letter of credit from an acceptable financial institution in an amount sufficient to secure payment equal to the applicable deposit amount. Other acceptable security may be considered. Irrevocable letters of credit that have an expiration date shall be renewed prior to that expiration date so that the account is always secured by a valid instrument. Failure or refusal to provide an updated irrevocable letter of credit will constitute grounds for interruption of service. Commercial account deposits will be waived for applying customers that have had a commercial service account with AUB within the past twelve months with acceptable payment history. Because of the potential for larger monthly bills and a risk for larger losses with a commercial account, a residential account cannot be used as credit consideration for opening a commercial account.

## 4.0 DEPOSIT AMOUNTS

AUB utilizes credit scores to determine deposit amounts required of applicants. The credit score places the applicant into one of three deposit requirement tiers:

- Credit score breakpoints:
  1. 669 – 850: No deposit required
  2. 576 – 668: Tier 1 deposit required
  3. 300 – 575: Tier 2 deposit required

	<b>Tier 1 Deposit Amount</b>	<b>Tier 2 Deposit Amount</b>
<b>Power</b>		
Residential	\$100.00	\$280.00
Small Comm.	\$200.00	\$480.00
Large C/I	\$7,000.00	\$18,000.00
<b>Water</b>		
Residential	\$20.00	\$60.00
Small Comm.	\$50.00	\$145.00
Large C/I	\$1,500.00	\$3,000.00
<b>Wastewater</b>		
Residential	\$30.00	\$95.00
Small Comm.	\$100.00	\$160.00
Large C/I	\$5,500.00	\$9,000.00
<b>Natural Gas</b>		
Residential	\$100.00	\$165.00
Small Comm.	\$300.00	\$360.00
Large C/I	\$18,000.00	\$18,000.00
Interruptible	\$85,000.00	\$85,000.00

## 4.1 USE OF A CO-SIGNER UPON APPLICATION FOR SERVICE

As outlined above, certain credit score levels will trigger the requirement for a deposit. If an applicant has no credit history returned from the credit reporting agency, a tier two deposit requirement will be indicated.

Alternatively, when an applying customer has no credit history, the customer may bring a co-signer to AUB. This willing party must be at the AUB main office in person, sign the application for services as a co-signer, provide all information and/or documentation required of any applicant, and agree to have a credit report run by AUB. The results of the co-signer's credit report will form the basis of any deposit required or for a waiver of deposit. The co-signer must remain on the account as an active account holder for the life of the account. The co-signer is agreeing to guarantee payment on the account and shall be responsible for any and all debts on the account if the primary account applicant does not pay. AUB can pursue the collection of any bad<sup>43</sup> debt on the account from the co-signer

using the same collection methods as are used with the primary applicant, including garnishing wages and filing suit if necessary. If the debt on the account is ever in default and written off as a loss, that fact may become part of the co-signer's credit report.

#### **4.2 FROZEN CREDIT REPORTS, SSN REFUSAL**

If an individual has frozen his/her credit report and does not wish to provide AUB with the Personal ID number that will allow a credit check to be run and a credit score obtained, a Tier Two deposit will be required.

Likewise, if an applicant refuses to provide his/her Social Security Number to allow a credit history to be checked and a score obtained, a Tier Two deposit will be required.

#### **5.0 DEPOSIT TERM**

Deposits, including any earned interest, shall be refunded to customers after one year if the customer maintains acceptable payment history. Interest will be credited to customers' utility accounts for all deposits held or refunded for more than one year. Interest will be credited annually to customers' utility accounts for all deposits that have not been refunded. The rate of interest to be paid will be based upon the rate of interest that the utility earns on its invested funds. Refunds of any remaining deposit monies will be made in the form of a credit to the customer's active utility account or, if the account is being closed, via a check sent via USPS mail.

Deposit balances, including any earned interest, are subject to review by the customer and AUB.

#### **6.0 TERMINATION OF SERVICE**

Deposits, including any earned interest, will be refunded to all customers upon termination of the applicable service. All customers requesting service termination should be referred to Customer Service. The Customer Service Representative accepting the termination request should first determine if the customer has an open deposit with the utility. Any amount on deposit should be applied to the customer's final utility bill. The Customer Service Representative will obtain a forwarding address for the customer. Any credit balance on the account after the deposit has been applied will be forwarded to the address supplied by the customer.

#### **7.0 Record Retention**

All records pertaining to customer deposits will be retained for six years after refund of the deposit.

Division of Accounting-Standard Policies and Procedures Manual Standard Policies and Procedures	
Policy Number: AUB-05-08	Revision Number: 4
Subject: Abandoned Property	Effective Date: 10-01-2009
	Superintendent Approval:
	General Manager Approval:

○ **PURPOSE**

Under [TCA 66-29-100/153], state law declares the following:

“The following funds held or owing by any utility are presumed abandoned:

- Any deposit made by a subscriber with a utility to secure payment, any sum overpaid, or any sum paid in advance for utility services to be furnished, less any lawful deductions, that has remained unclaimed by the person appearing on the records of the utility entitled thereto for more than two (2) years after the termination of the services for which the deposit, overpayment, or advance payment was made;
- Any sum that a utility has been ordered to refund by a court or administrative agency, together with any interest thereon, less any lawful deductions, which has remained unclaimed by the owner for more than two (2) years after it became payable in accordance with the final determination or order requires any person entitled to a refund to make a claim for it; and
- Property described above, without regard to any activity or inactivity within specified abandonment periods, whose owner is known to the holder to have died and left no one to take the property by will and no one to take the property by intestate succession.”

○ **UNCLAIMED PROPERTY**

All unclaimed property is required by law to be reported and turned over to the state treasurer, based on the following timetable:

- Utility deposits – 2 years after termination of service
- Wage checks – 1 year
- All other property – 5 years

**3.0 REPORTING**

All unclaimed property will be reported and turned over to the state treasurer’s office by May 1<sup>st</sup> each year. The abandoned property report will consist of property held as of the previous December 31. The report will be sent to the following address:

State Treasurer  
Division of Unclaimed Property  
Andrew Jackson Building, 11<sup>th</sup> Floor  
Nashville, TN 37243-0242



All unclaimed property reporting will be performed by financial accounting personnel under the supervision of the Superintendent of Accounting.

#### **4.0 CUSTOMER CONTACT**

If a customer's unclaimed property in the amount of \$50.00 or more is held, Athens Utilities Board (AUB) will attempt to contact the owner by first class mail between January 1, and May 1 of the year property is to be remitted to the state treasurer. Lists of unclaimed property held by AUB will not be published. Any customer's unclaimed property less than \$50.00 will be remitted to the state treasurer on May 1, as no customer contact is required.

#### **5.0 RECORD KEEPING DURATION**

All deposit records and employee payroll records shall be kept permanently. Under [TCA 68-29-113], utilities shall maintain a record of the name and last known address of the owner of unclaimed property for the (10) years after the property becomes reportable. Records of all unclaimed property shall be maintained by financial accounting personnel under the responsibility of the Superintendent of Accounting.

#### **6.0 EXCEPTIONS**

There shall be no exceptions to the above policy. In the event that any of the provision of the above policy conflict with Tennessee Code, the practice of AUB shall comply with the code.

Division of Accounting – Policies and Procedures Manual Standard Policies and Procedures	
Policy Number: - AUB-05-09	Revision Number: 4
Subject: Surplus Property	Effective Date: 10-01-2009
	Superintendent Approval:
	General Manager Approval:

## 1.0 Purpose

In order for Athens Utilities Board (AUB) to serve the public and to comply with the regulations and laws of the State of Tennessee and the Federal government, a consistent method of disposing of property that is no longer in use should be employed. By properly disposing of surplus property, AUB demonstrates proper stewardship of its responsibility to its customers.

### o Property with Value less than \$1,000.00

For property worth less than \$1,000.00, the General Manager will submit a list of property that should be declared surplus to the Board of Directors at a regular board meeting. This list should include, but not be limited to, the following:

- A brief description of the property;
- Location of the property;
- Property identification number(s);
- Estimated value of the property;

The board will approve, disapprove, or modify all or any part of the list and may assign higher or lower reasonable values to any items on the list. A copy of this list and the values assigned will be made part of the minutes of that board meeting. Once the listed property with values less than \$1,000.00 has been approved as surplus by the board, Management may dispose of the property in any of the following methods:

- Take proposals for purchase and accept the most appropriate;
- Sell the property as scrap, where the cost of other disposal exceeds the value of the property;
- Destroy the property, where the cost of other disposal exceeds the value of the property;
- Barter or exchange the property;
- Sell, trade or barter with any local government.

The General Manager will provide the Board of Directors a written report detailing the methods used to dispose of surplus property at the next Board meeting. The report should include the following information:

- The method of disposal;
- Payment received, if any;
- Who or what entity received the property;

- Receipt from the person or entity receiving the property, including itemized list of property with the dollar amount paid, and a signature of the person receiving the property;
- Any other information the General Manager feels appropriate.

- **Property with Values greater than \$1,000.00**

For property worth more than \$1,000.00, the General Manager will submit a list of property that should be declared as surplus to the Board of Directors at a regular Board meeting. This list should include, but not be limited to the following information:

- A brief description of the property;
- Location of the property;
- Property identification number(s);
- Estimated value.

The board will approve, disapprove, or modify all or any part of the list and may assign higher or lower reasonable values to any items on the list. A copy of this list and the values assigned will be made part of the minutes of that Board meeting. When the property has been declared surplus by the Board of Directors, Management may dispose of the property by advertising for bids for sale of the property in the local newspaper. The ad should be specific as to the method of bidding; the date, time and place of auction; date the bid must be received by AUB; method of payment required; location and inspection period; brief description of property; and other appropriate information deemed necessary. Upon completion of the surplus property sale, the General Manager will report to the Board in writing regarding the method of disposal. The report should include the following:

- 1 The method of disposal;
- 2 Payment received;
- 3 Who or what entity received the property;
- 4 Receipt from the person or entity receiving the property, including an itemized list of property with the dollar amount paid, and a signature of the person receiving the property.
- 5 Any other information deemed appropriate.

#### **4.0 Responsibility**

The Purchasing Manager will dispose of all surplus property under direction of the General Manager.

#### **5.0 Record Retention**

All records regarding disposition of surplus property will be kept ten years after disposition.

Division of Accounting – Policies and Procedures Manual Standard Policies and Procedures	
Policy Number: AUB-05-10	Revision Number : 5
Subject: Utility Records	Effective Date: 10-01-2009
	Superintendent Approval:
	General Manager Approval:

## 1.0 Purpose

Utilities in Tennessee must abide by the Public Records Act, [TCA 10-7-(101-606)]. This act requires that most utility documents must be open for public inspection by any citizen of the State of Tennessee. Athens Utilities Board (AUB) is run for the benefit of all present and future customers, and while no customer shall intentionally be treated unfairly, no customer shall be treated in a way that compromises the interests of other customers. The utility is subject to various state and federal regulations and has no discretion to provide or withhold utility records in a manner which would violate these regulations.

## 2.0 State Law Regarding Utility Records

All state, county and municipal records... shall at all times, during business hours, be open for public inspection by any citizen of Tennessee, and those in charge of such records shall not refuse such right of inspection to any citizen, unless otherwise provided by state law. [TCA 10-7-503]

Public records... mean all documents papers, letters, maps, books, photographs... electronic data... sound recordings or other material regardless of physical form or characteristics made or received pursuant to law or ordinance or in connection with the transaction of official business by any governmental agency. [TCA 10-7-301(6)]

### 6.1 Records Open to Public Inspection

In accordance with state law, the following is an example of utility records subject to public inspection:

- 6.1.2 Customer bills and usage records;
- 6.1.3 Customer mailing lists;
- 6.1.4 Customer payment delinquencies, cut-offs and payment histories;
- 6.1.5 Payroll records;
- 6.1.6 Minutes of meetings of the governing board;
- 6.1.7 Real and personal property records of the utility;
- 6.1.8 Purchases;
- 6.1.9 Accounting and bookkeeping records;
- 6.1.10 Operations and safety records and reports.

AUB will make these records available for inspection upon request of any resident of the state of Tennessee.

Customers of AUB can obtain all available historical information about their account during normal business hours simply by requesting the information from an AUB Customer Representative.

All of AUB's Policies and Procedures, as well as rate schedules for all rate classes across all divisions, are on AUB's website at [www.aub.org](http://www.aub.org) via links from the homepage.

Further, AUB issues news releases to regional media regarding all rate actions across all divisions, including monthly news releases regarding TVA's Total Fuel Cost adjustments and the resulting effective rates for the month to come.

○ **Records not Open for Public Inspection**

The following are records which are not subject to public inspection:

- Records relating to drug tests of employees;
- Records relating to an employee's treatment in a state or local government Employee Assistance Program;
- Medical records restricted by the Americans with Disabilities Act.

Before any employee medical records shall be divulged, the board will consult with the utility's attorney.

**5.0 How records will be provided**

Any customer or other state citizen requesting utility records will be provided them at the convenience of office staff. Original records are not to be taken from the offices of AUB except by court authority. Photocopies of records will be made available by the utility at the rate of \$.15 per one-sided page or as otherwise priced from time to time by the governing board. Computer disks will not be made available to the public [TCA 10-7-121(a)(2)]. Any person(s) requesting utility records will complete a "Request for Utility Records" form (copy attached). AUB employees will verify that the requestor is a citizen of the State of Tennessee and the information requested will not be resold or used for any commercial or illegal purpose. Records will only be provided for residents of the State of Tennessee or other customers of AUB.

**6.0 Record Retention**

The following will be used as a basis to determine how long records generated in the normal course of business will be retained. The list is not all inclusive.

1. **Years**
  - a. Correspondence
  
2. **Years**
  - a. Daily cash summaries
  - b. Bank deposit slips
  - c. Inventory records
  - d. Employee time records
  - e. Invoices

- f. Purchase orders
- g. Customer billing stubs
- h. Garnishments

### **6 Years**

1. Contracts (after maturity or cancellation)
2. Leases (after maturity)
3. Insurance policies
4. Claims records
5. Duplicate receipts
6. Canceled checks
7. Redeemed bond/interest coupons
8. Canceled certificates of deposit

### **10 years**

2. Accounts receivable detail records
3. Inventory ledgers
4. Cost records
5. Journal vouchers
6. Subsidiary revenue ledgers
7. Expense ledgers
8. Voucher or check register

### **PERMANENT Records**

- Audit and financial reports
- Bond and interest ledgers
- Certificate of bonds and interest coupons destroyed
- Charts of accounts and procedure manuals
- Deeds and other title documents
- Employee payroll records
- Fixed asset records
- General ledgers and cash journals
- Investment security or trust records
- Deposit records
- Special assessment ledgers

## Request for Utility Records

Division of Accounting – Policies and Procedures Manual Standard Policies and Procedures	
Policy Number – AUB-05-11	Effective date: December 15, 2011
Subject: Debt Management Policy	Superintendent Approval:

Any citizen of the State of Tennessee may inspect utility records during normal business hours, as restricted by TCA 10-7-503. To assist the utility in verifying your right to inspect its records and to locate the records you desire to inspect, please complete the following:

Your name: \_\_\_\_\_

Mailing Address: \_\_\_\_\_

Street Address: \_\_\_\_\_

Tennessee Driver License No.: \_\_\_\_\_

Or Voter Registration Card: \_\_\_\_\_

Specific Description of Records Requested: \_\_\_\_\_

\_\_\_\_\_  
\_\_\_\_\_  
\_\_\_\_\_

I certify that I am a citizen of the State of Tennessee and this information is NOT requested for resale or any commercial or illegal purpose.

Signature: \_\_\_\_\_

Date and Time: \_\_\_\_\_

:By \_\_\_\_\_

Signature of utility staff person overseeing request.

	General Manager Approval:
--	---------------------------

**ATHENS UTILITIES BOARD  
ATHENS, TENNESSEE**

**Debt Management Policy**

Formally Adopted: December 15, 2011



## TABLE OF CONTENTS

Introduction .....	55
Introductory Statement.....	56
Goals and Objectives.....	56
Procedures for the Issuance of Debt.....	57
Credit Quality and Credit Enhancement.....	58
Affordability.....	58
Debt Structure .....	58
Debt Types .....	60
Use of Derivatives.....	62
Refinancing Outstanding Debt .....	62
Methods of Issuance.....	63
Professionals .....	65
Compliance .....	67
Debt Policy Review.....	68

## **INTRODUCTION**

This Debt Management Policy (the “Debt Policy”) is a written guideline with parameters that affect the amount and type of debt that can be issued by the Athens Utilities Board (the “Utility”), the issuance process, and the management of the Utility’s debt. The purpose of this Debt Policy is to improve the quality of management and legislative decisions and to provide justification for the structure of debt issuances consistent with the Debt Policy’s goals while demonstrating a commitment to long-term capital planning. It is also the intent of the Utility that this Debt Policy will signal to credit rating agencies, investors, and the capital markets that Athens Utilities Board is well managed and will always be prepared to meet its obligations in a timely manner. This Debt Policy fulfills the requirements of the State of Tennessee regarding the adoption of a formal debt management policy on or before January 1, 2012.

This Debt Policy provides guidelines for the Utility to manage its debt and related annual costs within both current and projected available resources while promoting understanding and transparency for our citizens, rate payers, businesses, investors and other interested parties.

Athens Utilities Board may, from time to time, review this Debt Policy and make revisions and updates, if warranted.

**Athens Utilities Board  
DEBT MANAGEMENT POLICY**

**8 INTRODUCTORY STATEMENT**

In managing its Debt (defined herein as tax-exempt or taxable bonds, capital outlay notes, other notes, capital leases, interfund loans or notes, and loan agreements); it is the Utility’s policy to:

**1.0** Achieve the lowest cost of capital within acceptable risk parameters

(1) Maintain or improve credit ratings

3 Assure reasonable cost access to the capital markets

4 Preserve financial and management flexibility

**2** Manage interest rate risk exposure within acceptable risk parameters

**9 GOALS AND OBJECTIVES**

Debt policies and procedures are tools that ensure that financial resources are adequate to meet the Utility’s long-term capital planning objectives. In addition, the Debt Policy helps to ensure that financings undertaken by Athens Utilities Board have certain clear, objective standards which allow the Utility to protect its financial resources in order to meet its long-term capital needs.

The Debt Policy formally establishes parameters for issuing debt and managing a debt portfolio which considers Athens Utilities Board’s specific capital improvement needs, ability to repay financial obligations, and existing legal, economic, and financial market conditions. Specifically, the policies outlined in this document are intended to assist in the following:

a. To guide the Utility in policy and debt issuance decisions

a. To maintain appropriate capital assets for present and future needs

a. To promote sound financial management

- To protect the Utility’s credit rating

**1.0** To ensure the Utility’s debt is issued legally under applicable state and federal laws

5.0 To promote cooperation and coordination with other parties in the financing

- To evaluate debt issuance options

## 10 PROCEDURES FOR ISSUANCE OF DEBT

### 10.1 Authority

1. The Utility will only issue debt by utilizing the statutory authorities provided by *Tennessee Code Annotated* (“TCA”) as supplemented and revised and the Internal Revenue Code (the “Code”).
2. The Utility will adhere to any lawfully promulgated rules and regulations of the State and those promulgated under the Code.
3. The Utility is a component unit of the City of Athens, Tennessee. It is an enterprise fund of the City consisting of four distinct divisions (Power, Water, Gas and Wastewater Treatment). Each division is a separate economic entity with its own separate funds and accounting records. Each division is managed by a Superintendent, and each of the Superintendents reports directly to the General Manager who manages the all divisions of the Utility. The General Manager reports to a five-member Board of Directors that is responsible for the Utility as a whole. The Board of Directors is composed of four stake holders of the Utility and one City Council representative of the City of Athens, Tennessee. All of the Utility’s debt will be presented to, and approved by, the Utility’s Board of Directors. As a component unit of the City, all debt of the Utility must be presented to, and approved by, the City Council after approval of the Utility’s Board of Directors.

### 10.2 Transparency

- 1 It is recognized that the issuance of debt must have various approvals and on occasion, written reports provided to the State of Tennessee Comptroller’s office either prior to adoption of resolutions authorizing such debt, prior to issuance and/or following issuance. The Utility, in conjunction with any professionals (including, but not limited to, financial advisors, underwriters, bond counsel, etc. which may individually or collectively be referred to herein as “Financial Professionals”) will ensure compliance with TCA, the Code and all federal and state rules and regulations. Such State compliance will include, but not be limited to, compliance with all legal requirements regarding adequate public notice of all meetings of the Utility related to consideration and approval of debt. In the interest of transparency, all costs (including interest, issuance, continuing and one-time) shall be disclosed to its legislative body, citizens and other interested parties in a timely manner. Additionally, the Utility shall provide the Tennessee Comptroller’s office sufficient information on the debt to not only allow for transparency regarding the issuance, but also assuring that the Comptroller’s office has sufficient information to adequately report or approve any formal action related to the sale and issuance of debt. The Utility will also make this information available to its legislative body, citizens and other interested parties.
- 2 The Utility will file its Audited Financial Statements and any Continuing Disclosure document prepared by the Utility or it’s Dissemination Agent. To promote transparency and understanding, these documents should be furnished to members of the Legislative Body and made available by usual and customary means to its citizens, taxpayers, rate payers, businesses, investors and other interested parties.

## **11 CREDIT QUALITY AND CREDIT ENHANCEMENT**

The Utility's Debt management activities will be conducted in order to maintain or receive the highest possible credit ratings. The Utility, in conjunction with any financial professionals that the Utility may choose to engage, will be responsible for maintaining relationships and communicating with one or more rating agencies.

The Utility will consider the use of credit enhancements on a case-by-case basis, evaluating the economic benefit versus cost for each case. Only when clearly demonstrable savings can be shown shall an enhancement be considered. The Utility will consider each of the following enhancements as alternatives by evaluating the cost and benefit of such enhancements.

### **3 Insurance**

The Utility may purchase bond insurance when such purchase is deemed prudent and advantageous. The predominant determination shall be based on such insurance being less costly than the present value of the difference in the interest on insured bonds versus uninsured bonds.

### **4 Letters of Credit**

The Utility may enter into a letter-of-credit ("LOC") agreement when such an agreement is deemed prudent and advantageous. The Utility or its financial professionals, if any, may seek proposals from qualified banks or other qualified financial institutions pursuant to terms and conditions that are acceptable to the Utility's Board of Directors.

## **12 AFFORDABILITY**

The Utility shall consider the ability to repay debt as it relates to the total budget resources, the financial performance of the applicable division of the Utility, and other revenues available to service the Debt. The Utility may consider debt ratios and other benchmarks compared to its peers when analyzing its debt including materials published by the nationally recognized credit rating agencies.

## **13 DEBT STRUCTURE**

The Utility shall establish all terms and conditions relating to the issuance of debt and will invest all bond proceeds pursuant to the terms of its investment policy, if any. Unless otherwise authorized by the Utility's Board of Directors, the following shall serve as the Debt Policy for determining structure.

### **a) Term**

All capital improvements financed through the issuance of debt will be financed for a period not to exceed the useful economic life of the improvements and in consideration of the ability of the Utility to absorb such additional debt service cost. The term of debt shall be determined by, but not limited to, the economic life of the assets financed, conditions in the capital markets, the availability of

adequate revenue streams to service the debt, and the existing pattern of debt payable from the applicable division of the Utility, but in no event will the term of such debt exceed forty (40) years.

**b) Capitalized Interest**

From time to time, certain financings may require the use of capitalized interest from the date of issuance until the Utility is able to realize beneficial use and/or occupancy of the financed project. Interest may be capitalized through a period permitted by federal law and TCA if it is determined that doing so is beneficial to the financing by the Utility's Board of Directors and is appropriately memorialized in the legislative action authorizing the sale and issuance of the debt.

**c) Debt Service Structure**

General Obligation debt issuance shall be planned to achieve relatively net level debt service or level principal amortization considering the Utility's outstanding debt obligations, while matching debt service to the useful economic life of facilities. Absent events or circumstances determined by its Board of Directors, the Utility shall avoid the use of bullet or balloon maturities (with the exception of sinking fund requirements required by term bonds) except in those instances where such maturities serve to make existing overall debt service level or match specific income streams. Debt which is supported by project revenues and is intended to be self-supporting should be structured to achieve level proportional coverage to expected available revenues.

**d) Call Provisions**

In general, the Utility's Debt should include a call feature no later than ten (10) years from the date of delivery of the bonds. The Utility will avoid the sale of long-term debt which carries longer redemption features unless a careful evaluation has been conducted by the Utility and/or financial professionals, if any, with respect to the value of the call option and the financial goals of the Utility.

**e) Original Issuance Discount/Premium**

Debt with original issuance discount/premium will be permitted.

**f) Deep Discount Bonds**

Deep discount debt may provide a lower cost of borrowing in certain capital markets. The Utility and/or financial professionals, if any, should carefully consider their value and effect on any future refinancing as a result of the lower-than-market coupon.

## 14 DEBT TYPES

When the Utility determines that debt is appropriate, the following criteria will be used to evaluate the type of debt to be issued.

### I. Security Structure

#### 1) Revenue Debt

The Utility may issue debt supported exclusively with revenues generated by one of its four divisions (“Revenue Debt”), where repayment of the debt service obligations on such Revenue Debt will be made through revenues generated from that division of the Utility.

#### 2) Capital Leases

The Utility may use capital leases to finance projects assuming the Utility and/or financial professionals, if any, determine that such an instrument is economically feasible.

### II. Duration

#### 1) Long-Term Debt

The Utility may issue long-term debt when it is deemed that capital improvements should not be financed from current revenues or short-term borrowings. Long-term debt will not be used to finance current operations or normal maintenance. Long-term debt will be structured such that financial obligations do not exceed the expected useful economic life of the project(s) financed.

- a) *Serial and Term Debt*. Serial and Term Debt may be issued in either fixed or variable rate modes to finance capital infrastructure projects;
- b) *Capital Outlay Notes (“CONs”)*. CONs may be issued to finance capital infrastructure projects with an expected life up to twelve years; or
- c) *Capitalized Leases*. Capitalized Leases may be issued to finance infrastructure projects or equipment with an expected life not greater than its expected useful life.

#### 2) Short-Term Debt

Short-term borrowing may be utilized for:

- a) Financing short economic life assets;
- b) The construction period of long-term projects;
- c) For interim financing; or
- d) For the temporary funding of operational cash flow deficits or anticipated

revenues subject to the following policies:

- *Bond Anticipation Notes (“BANs”)*. BANs, including commercial paper notes issued as BANs, may be issued instead of capitalizing interest to reduce the debt service during the construction period of a project or facility. The BANs shall not mature more than 2 years from the date of issuance. BANs can be rolled in accordance with federal and state law. BANs shall mature within 6 months after substantial completion of the financed facility.
- *Revenue Anticipation Notes (“RANs”)* shall be issued only to meet cash flow needs consistent with a finding by bond counsel that the sizing of the issue fully conforms to the Code and state requirements and limitations.
- *Lines of Credit*. Lines of Credit shall be considered as an alternative to other short-term borrowing options. A line of credit shall only be structured to federal and state requirements.
- *Other Short-Term Debt*. Other Short-Term Debt including commercial paper notes, BANs, Capitalized Leases and CONs may be used when it provides an interest rate advantage or as interim financing until market conditions are more favorable to issue debt in a fixed or variable rate mode. The Utility will determine and utilize the most advantageous method for short-term borrowing. The Utility may issue short-term Debt when there is a defined repayment source or amortization of principal.

### **III. Interest Rate Modes**

#### **1) Fixed Rate Debt**

To maintain a predictable debt service schedule, the Utility may give preference to debt that carries a fixed interest rate.

#### **2) Variable Rate Debt**

The Utility recognizes the value of variable rate debt obligations in certain circumstances and that government entities have benefitted from the use of variable rate debt in the financing of infrastructure and capital improvements. The Utility also recognizes that there are inherent risks associated with the use of variable rate debt. To mitigate these risks, the Utility will:

- a) Monitor historical and projected interest rates for variable rate debt
- b) Reasonably limit the total outstanding variable rate debt in relation to total debt. Management will monitor interest rates and take appropriate steps to fix interest rates in the event of increasing interest costs. The analysis of variable rate debt costs will take into consideration the amount and investment strategy of the Utility’s operating cash. Long term financial planning will consider the possible impact of increasing interest costs associated with variable rate debt.



## 15 USE OF DERIVATIVES

As of 7/1/2011, the Utility has no outstanding derivatives with its debt portfolio. The Utility has no plans to use derivatives or other similar financial structures in the future. Prior to any reversal of this provision:

**15.1** A written management report prepared by the Utility and/or financial professionals, if any, outlining the potential benefits and consequences of utilizing these structures must be submitted to the Utility's Board of Directors and the City Council; and

**15.2** The Utility's Board of Directors must adopt a specific amendment to this policy concerning the use of derivatives or interest rate agreements that complies with the State Funding Board guidelines.

## 16 REFINANCING OUTSTANDING DEBT

Athens Utilities Board may refund debt when it is in the best financial interest of the Utility to do so. The Utility in conjunction with financial professionals, if any, shall have the responsibility to analyze outstanding debt for refunding opportunities. The decision to refinance must be explicitly approved by the Utility's Board of Directors and the City Council, and all plans for current or advance refunding of debt must be in compliance with all state laws and regulations.

The General Manager, Assistant General Manager and Superintendent of Accounting will consider the following issues when analyzing possible refunding opportunities:

### **16.1 Onerous Restrictions**

Debt may be refinanced to eliminate onerous or restrictive covenants contained in existing debt documents.

### **16.2 Restructuring for economic purposes**

The Utility may also refund debt when it is in its best financial interest to do so. Such a refunding will be limited to restructuring to meet unanticipated revenue expectations, achieve cost savings, mitigate irregular debt service payments, release reserve funds or remove unduly restrictive bond covenants or any other reason approved by the Utility Board of Directors in its discretion.

### **16.3 Term of Refunding Issues**

Normally, the Utility will refund debt equal to or within its existing term. However, the Utility may consider maturity extension, when necessary to achieve desired outcomes, provided that such extension is legally permissible and it is approved by the Utility's Board of Directors and the City Council. The Utility may also consider shortening the term of the originally issued debt to realize greater savings. The remaining useful economic life of the financed facility and the concept of inter-generational equity should guide these decisions.

## **16.4 Escrow Structuring**

The Utility shall use the least costly securities available in structuring refunding escrows. In the case of open market securities, a certificate will be provided by a third party agent, who is not a broker-dealer stating that the securities were procured through an arms-length, competitive bid process, that such securities were more cost effective than State and Local Government Obligations (SLGS), and that the price paid for the securities was reasonable within Federal guidelines. In cases where taxable debt is involved, the Utility, with the approval of bond counsel, may make a direct purchase as long as such purchase is the most efficient and least costly. Under no circumstances shall an underwriter, agent or any financial professionals sell escrow securities involving tax-exempt debt to the Utility from its own account.

## **16.5 Arbitrage**

The Utility shall take all necessary steps to optimize escrows and to avoid negative arbitrage in its refunding. Any positive arbitrage will be rebated as necessary according to Federal guidelines.

## **METHODS OF ISSUANCE**

- a) The Utility may consult with a financial professional regarding the method of sale of debt. Subject to approval by the Utility's Board of Directors and the City Council, the Utility will determine the method of issuance of debt on a case-by-case basis consistent with the options provided by prevailing State law.

### **Competitive Sale**

- In a competitive sale, the Utility's debt will be offered in a public sale to any and all eligible bidders. Unless bids are rejected, the debt shall be awarded to the bidder providing the lowest true interest cost as long as the bid adheres to the requirements set forth in the official notice of sale.

In a competitive sale, a financial advisor may bid on an issue for which they are providing advisory services only if:

- Authorized by the rules and regulations of the Municipal Securities Rulemaking Board (the "MSRB"), including Rule G-23, as may be amended and modified;
- The Legislative Body or designated official grants in writing specific authority on a transaction by transaction basis;
- Such sale is properly carried out through a widely and publicly advertised sale, during normal bond sale hours, and through an industry standard, electronic bidding platform; and

- The financial advisory fee is separately disclosed and billed from the underwriting fee.

- **Negotiated Sale**

The Utility recognizes that some securities are best sold through a negotiated sale with an underwriter or group of underwriters. The Utility shall assess the following circumstances in determining whether a negotiated sale is the best method of sale:

- State requirements on negotiated sales;
- Debt structure which may require a strong pre-marketing effort such as those associated with a complex transaction generally referred to as a "story" bond;
- Size or structure of the issue which may limit the number of potential bidders;
- Market conditions including volatility wherein the Utility would be better served by the flexibility afforded by careful timing and marketing such as is the case for debt issued to refinance or refund existing debt;
- Whether the debt is to be issued as variable rate obligations or perhaps as zero coupon debt;
- Whether an idea or financing structure is a proprietary product of a single firm;

- In a publicly offered or privately placed, negotiated sale, a financial advisor, if any, shall not be permitted to resign as the financial advisor in order to underwrite or privately place an issue for which they are or have been providing advisory services;
- The underwriter shall clearly identify itself in writing as an underwriter and not as a financial advisor from the earliest stages of its relationship with the Utility with respect to the negotiated issue. The underwriter must clarify its primary role as a purchaser of securities in an arm's length commercial transaction and that it has financial and other interests that differ from those of the Utility. The underwriter in a publicly offered, negotiated sale shall be required to provide pricing information both as to interest rates and to takedown per maturity to the legislative body (or its designated official) in advance of the pricing of the debt.

- **Private Placement**

From time to time, the Utility may elect to privately place its debt. Such placement shall only be considered if this method is demonstrated to be advantageous to the Utility.

## b) **PROFESSIONALS**

### 1) **Financial Professionals**

As needed, the Utility may select financial professionals to assist in its debt issuance and administration processes. In selecting financial professionals, consideration should be given with respect to:

- relevant experience with municipal government issuers and the public sector;
- indication that the firm has a broadly based background and is therefore capable of balancing the Utility's overall needs for continuity and innovation in capital planning and debt financing;
  - experience and demonstrated success as indicated by its experience;
  - the firm's professional reputation;
  - professional qualifications and experience of principal employees; and
- the estimated costs, but price should not be the sole determining factor.

## 2) Miscellaneous

- **Written Agreements**

- Any financial professionals engaged by the Utility shall enter into written agreements including, but not limited to, a description of services provided and fees and expenses to be charged for the engagement.
- The Utility shall enter into an engagement letter agreement with each lawyer or law firm representing the Utility in a debt transaction. No engagement letter is required for any lawyer who is an employee of the Utility or lawyer or law firm which is under a general appointment or contract to serve as counsel to the Utility. Athens Utilities Board does not need an engagement letter with counsel not representing the Utility, such as underwriters' counsel.
- The Utility shall require all financial professionals engaged in the process of issuing debt to clearly disclose all compensation and consideration received related to services provided in the debt issuance process by both the Utility and the lender or conduit issuer, if any. This includes "soft" costs or compensations in lieu of direct payments.
- If the Utility chooses to hire financial advisors, it will enter into a written agreement with each person or firm serving as financial advisor for debt management and transactions. Whether in a competitive sale or negotiated sale, the financial advisor will not be permitted to bid on, privately place or underwrite an issue for which they are or have been providing advisory services for the issuance.
- If there is an Underwriter, the Utility will require the underwriter to clearly identify itself in writing (e.g., in a response to a request for proposals or in promotional materials provided to an issuer) as an underwriter and not as a financial advisor from the earliest stages of its relationship with the Utility with respect to that issue. The underwriter must clarify its primary role as a purchaser of securities in an arm's-length commercial transaction and that it has financial and other interests that differ from those of the Utility. The underwriter in a public offered, negotiated sale will be required to provide pricing information both as to interest rates and to takedown per maturity to the Utility's Board of Directors and the City Council in advance of the pricing of the debt.

### 1) Conflict of Interest

- Financial professionals involved in a debt transaction hired or compensated by the Utility shall be required to disclose to the Utility existing client and business relationships between and among the professionals to a transaction (including but not limited to financial advisors, swap advisors, bond counsel, swap counsel, trustee, paying agent, underwriter, counterparty, and remarketing agent), as well as conduit

issuers, sponsoring organizations and program administrators. This disclosure shall include that information reasonably sufficient to allow the Utility to appreciate the significance of the relationships.

Financial Professionals who become involved in the debt transaction as a result of a bid submitted in a widely and publicly advertised competitive sale conducted using an industry standard, electronic bidding platform are not subject to this disclosure. No disclosure is required that would violate any rule or regulation of professional conduct.

### c) **COMPLIANCE**

- **Continuing Annual Disclosure**

Normally at the time debt is delivered, the Utility will execute a Continuing Disclosure Certificate in which it will covenant for the benefit of holders and beneficial owners of the publically traded debt to provide certain financial information relating to the Utility by not later than twelve months after each of the Utility's fiscal years, (the "Annual Report) and provide notice of the occurrence of certain enumerated events. The annual report (and audited financial statements, if filed separately) will be filed with any State Information Depository (the "SID") established in the State of Tennessee. If the Utility is unable to provide the annual report to the SID by the date required, notice of each failure will be sent to the SID on or before such date. The notices of certain enumerated events will be filed by the Utility with the SID. The specific nature of the information to be contained in the annual report or the notices of significant events is provided in each Continuing Disclosure Certificate. These covenants are made in order to assist underwriters in complying with SEC Rule 15c2-12(b) (the "Rule").

- **Arbitrage Rebate**

The Utility will also maintain a system of record keeping and reporting which complies with the arbitrage rebate compliance requirements of the Internal Revenue Code (the "Code").

- **Records**

The Utility will also maintain records required by the Code including, but not limited to, all records related to the issuance of the debt including detailed receipts and expenditures for a period up to 6 years following the final maturity date of the debt or as required by the Code.

d) **DEBT POLICY REVIEW**

- **General Guidance**

The guidelines outlined herein are only intended to provide general direction regarding the future issuance of debt. The Utility maintains the right to modify this policy and may make exceptions to any of its guidelines at any time to the extent that the execution of such debt achieves the goals of the Utility as long as such exceptions or changes are consistent with TCA and any rules and regulations promulgated by the State.

This policy should be reviewed from time to time as circumstances, rules and regulations warrant.

- **Designated Official**

The General Manager and Superintendent of Accounting are responsible for ensuring substantial compliance with this policy.

<b>Division of Accounting – Policies and Procedures Manual</b>	
<b>Standard Policies and Procedures</b>	
<b>Policy Number – AUB-05-12</b>	<b>Revision Number: 1</b>
<b>Subject: Evaluation Process for Vehicle Purchases</b>	<b>Effective Date: 7/1/2014</b>
	<b>Superintendent Approval:</b>
	<b>General Manager Approval:</b>

1) **PURPOSE**

The purpose of this policy is to establish the policy of Athens Utilities Board (AUB) for evaluating vehicles for purpose of purchasing.

2) **SCOPE**

This policy applies to all vehicles purchased by AUB.

3) **REFERENCES**

- ✓ Athens Utilities Board Accounting Policy, AUB-05-04, Purchasing

4) **GENERAL**

All vehicles purchased by AUB will typically be subject to Accounting Policy AUB-05-04, because any vehicle purchased will likely be above the threshold of \$10,000 and will require competitive bidding. The Board has adopted a general guideline for the purchase/replacement of vehicles that specifies that a vehicle must be at least 5 years old and/or have at least 100,000 miles registered on the odometer before it is considered for replacement. Another consideration is that the Board is making a conscious effort to convert the fleet to CNG. Currently AUB has a contractual agreement to purchase CNG from Waypoint until June 2018. After this date, AUB will install slow fill stations to fuel our CNG fleet at a reduced cost compared to current pricing from Waypoint. This will significantly change the lifetime cost evaluation of a CNG vehicle as presented in Section 6.2 of this policy.

5) **DEFINITIONS**

- AUB** – the Athens Utilities Board, and its duly authorized employees, agents and representatives
- Board** – the Chairman and all Commissioners but does not include any employees
- CNG** – Compressed Natural Gas
- GGE** – Gasoline Gallon Equivalent

6) **POLICY/PROCEDURES**

AUB vehicle purchases shall be conducted in accordance with AUB-05-04, Purchasing.



Superintendents will be responsible for planning vehicle replacement and including those vehicles to be replaced into the strategic plan and eventually the annual capital budget. Only in extreme situations (for example a vehicle destroyed in an accident) will a vehicle purchase be considered if the vehicle has not been included within the fiscal year capital budget. Vehicles that are being used as a “trade-in” will be made available for dealers to inspect within the normal operating hours of AUB. The Board has also specified that all vehicles to be purchased will include an alternate converted CNG bid or, at a minimum, have the capability to be converted to CNG when possible.

## **6.1 VEHICLE SPECIFICATIONS**

The superintendent (or designee) of the division that is purchasing a vehicle will be responsible for providing a completed specification check list to the purchasing manager. The purchasing manager will then provide these specification sheets to the appropriate vendors dependent upon the type of vehicle being purchased. In some instances, more than one vendor is required if ancillary equipment or work beds are required to be installed on base vehicle frames. The purchasing manager will collect bids and present them to the superintendent for evaluation.

## **6.2 BID EVALUATION**

The purchasing manager will return all bids to the division superintendent (or designee) for evaluation of the bid as compared to specifications and pricing. The initial evaluation will be to determine the responsiveness of the bid. For example, does the bid meet all specifications? If not, are the items that do not meet specification of such value, or of such need for daily operations, that the bid is considered non-responsive or “not meeting specifications” and is rejected for further consideration.

All responsive bids will be organized in tabulated form including the dealer/vendor name, original value of the vehicle being bid, any discounts (fleet, TVPPA, state, or dealer discounts), trade-in value, and net price, EPA estimated COMBINED MPG (from “fueleconomy.gov which is the official U.S. government source for fuel economy information), estimated cost of fuel for 120,000 miles calculated at current fuel cost plus escalation factor of 15% for five year life of vehicle, estimated CNG fuel cost for 120,000 miles calculated at current Waypoint price less \$.50 (AUB’s current margin per GGE) with no anticipated escalation. An example is shown below using initial market values (before adjustment) of \$3.25 for gas and \$2.49 for Waypoint CNG:

Dealership	Gross Bid	Discount	Trade In	Net Bid	MPG	Fuel Cost \$ 3.74	CNG Cost \$ 1.99	CNG Conv	Cost plus Fuel	Cost plus CNG
Jackie Jones Ford	No Bid									
Ted Russell Ford	No Bid									
L & M Motors	\$ 35,954.00	\$ 7,750.00	\$ -	\$28,204.00	15	\$29,900.00	\$15,920.00	\$10,000	\$58,104.00	\$54,124.00
Ted Russell Nissan	\$ 40,492.00	\$ 7,000.00	\$ -	\$33,492.00	14	\$32,035.71	\$17,057.14	\$10,000	\$65,527.71	\$60,549.14
Don Ledford	\$ 37,950.00	\$ 6,900.00	\$ -	\$31,050.00	18	\$24,916.67	\$13,266.67	\$10,000	\$55,966.67	\$54,316.67

The information provided in this table will allow a number of comparisons based on factors ranging from gross bid to overall cost of vehicle plus fuel. Input data for the table can be changed to reflect the actual values for fuel and expected lifetime mileage at the time of bid. Conversion costs for CNG vehicles will vary dependent upon type vehicle and tankage requirements, but should begin to reduce in price as production increases to meet demand. Likewise, CNG fuel rates will decrease as contractual terms are met with Waypoint and AUB installs its own CNG slow-fill facilities for vehicles.

### 6.3 Recommendation to Board

The division superintendent will use the bid tabulation to provide a write-up for the Board that will recommend the *best* bid for the vehicle. Cost should always be considered a primary factor when evaluating bids. However, low-bid does not always mean lowest cost (in terms of lifetime cost). In essence, low bid is not always the best bid unless one is comparing identical products.

With regard to comparing CNG and Fuel (gas or diesel), a number of factors must be considered. The evaluation of whether to move forward with a CNG conversion involves more than just the possible break-even or reduction in overall cost plus fuel. There are intrinsic values associated with CNG including: it is a lower carbon emission fuel than gasoline or diesel; it is a domestic product of the United States (reduces our dependency on foreign oil); it is a “cleaner” fuel from a total emissions standpoint than gasoline or diesel; CNG engines tend to cost less to maintain; CNG vehicles require less frequent oil changes; and volatility in the natural gas market is significantly lower (primarily a US Market) than in the gasoline and diesel markets (worldwide petroleum markets) providing fleet managers with long term and predictable fuel cost. To account for these favorable “cost” factors, plus the eventuality of AUB building its own fueling stations on-site at a greatly reduced fuel cost rate compared to the current Waypoint station pricing, AUB will favor and recommend CNG vehicles when overall costs are within 5 % of petroleum.

Division of Accounting – Policies and Procedures Manual Standard Policies and Procedures	
Policy Number: AUB-05-13	Revision Number : 0
Subject: Fair and Accurate Credit Transactions Act (FACTA) Compliance	Effective Date: Nov. 1, 2008
	Privacy Officer Approval: WS
	General Manager Approval:ETN

- **Purpose**

Utilities in Tennessee must abide by the Fair and Accurate Credit Transactions Act (FACTA). This act requires that most creditors (including municipal utilities by definition) develop a documented program designed to detect, prevent, and mitigate identity theft in connection with the opening of an account or an existing account. This policy and procedure will serve to document the Athens Utilities Board’s program and compliance with the requirements of the FACTA.

- **References**

(1) “Identity Theft Red Flags and Address Discrepancies under the Fair and Accurate Credit Transactions Act of 2003; Final Rule” - Federal Register, Volume 72, Number 217, Friday, November 9, 2007

- **Definitions**

**AUB** – means the Athens Utilities Board, and its duly authorized employees, agents, and representatives

**Board** – means the Chairman and all Commissioners but does not include any employees

**Customer** – Any person, business, or other entity that receives electrical service from Athens Utilities Board, Division of Power

**Division** – The Athens Utilities Board, division of Power, Water, wastewater, or gas

**FACTA** – Fair and Accurate Credit Transactions Act

**IDT** – Identity Theft

#### **4.0 Identity Theft Prevention Plan**

The Identity Theft Prevention Plan lays out the basic steps that will be taken by AUB to prevent, identify, and mitigate IDT consistent with the purpose of FACTA and to protect our customer base from IDT.

The Identity Theft Plan is included in this Policy and Procedure as Attachment PP AUB-05-11- A1

- **Designation of Privacy Officer**

As required by FACTA, AUB has designated the Assistant General Manager as the current privacy officer responsible for the establishment and oversight of the compliance program. Wayne Scarbrough is the designated Privacy Officer and all concerns or inquiries regarding FACTA should be directed to the Privacy Officer as a single point of contact to investigate and address any issues related IDT Red Flags.

1. **Updates to Plan on “As Needed” Basis**

The Privacy Officer is also responsible for ensuring that the program is updated whenever risks parameters change that could affect safety and soundness of the security of customer data.

2. **Annual Report**

The Privacy Officer will present an annual report of the Privacy Committee’s activity to AUB’s board of directors for review and approval. The report will include any incidents reported during the period and will outline the Privacy Committee’s plans regarding necessary program revisions.

- **Designation of Privacy Committee**

As required by FACTA, AUB has appointed a Privacy committee that represents at least three critical areas that are most susceptible to identity theft and have responsibility for identifying Red Flags to help detect and mitigate IDT.

## Privacy Committee Members

<b>Member Name</b>	<b>Title</b>	<b>Key Area(s)</b>
Chuck Forrest	IT Manager	Information Technology, Internal/External communications portals and protocols, customer database, system security
Phil Graves	Director of Management Services	Human Resources, internal personnel databases, internal medical records, payroll database information
Eric Newberry	General Manager	Executive Management, General Oversight
Doug Rodgers	Director of Accounting	Chief Financial Officer, general accounting, plant accounting, account payments, bank draft, information technology
Wayne Scarbrough	Assistant General Manager	Executive Management, Customer Service, customer account initiation, customer data collection, overall compliance

### 6.1 Privacy Committee Roles and Responsibilities

#### 6.1.1 Needs Assessment

The Privacy Committee, in consultation with various task area employees at AUB, will complete a Needs Assessment to help the Privacy Committee identify AUB's strengths and weaknesses relative to ID Theft prevention, identification, and mitigation.

The Needs Assessment is included in this Policy and Procedure as Attachment PP AUB-05-11-A2

## **1. FACTA Compliance Checklist**

The Privacy Committee will complete a checklist of FACT act planning/implementation activities, AUB operations relative to collection/use of sensitive customer information, IT/data security measures, and other pertinent task areas to ensure we cover all requirements and/or needs to implement and maintain a successful ID Theft Prevention, Identification and Mitigation Program.

The FACTA Compliance Checklist is included in this Policy and Procedure as Attachment PP AUB-05-11-A3

### **6.1.3 Develop New and Revise Existing Policies to Ensure FACTA Compliance**

The Privacy Committee will write/revise policies and procedures relative to:

- a) Training pertinent employees on a need-to-know basis regarding identification of Red Flags that may indicate ID theft activity.
- b) Actions to be taken arising from Red Flags.
- c) Preventing, Identifying and Mitigating Security Breeches
- d) IT audits to monitor risks for theft
- e) Reporting ID theft
- f) Responding to address discrepancies

#### **1. Training Employees Responsible for FACTA Related Information**

Members of the Privacy Committee will train all pertinent employees on a need-to-know basis relative to their role in AUB's program. Refresher training will occur at least once annually.

#### **2. Meeting of Privacy Committee**

The Privacy Committee will meet at least quarterly to discuss any reported incidents or red flag occurrences and will document any AUB actions including necessary revisions to this plan or to policies/procedures.

- **Miscellaneous Administrative Policies/Procedures**

As required by FACTA, AUB has developed a number of policies/procedures related to various aspects of Red Flag identification, training and response by employees. These miscellaneous policies and procedures are listed below and included as Attachment PP AUB-05-11- A4.

A - Employee Training

B - Defining Actions from Red Flag Identification

C - Preventing, Detecting, and Mitigating Security Breaches

D - Disposal of Records

E - IT Audits to Monitor Risk

F - Response to Address Discrepancies

G - Request for Customer Account Information

H - Reporting ID Theft

## **Attachment AUB PP 05-11-A4**

### **Miscellaneous Policies and Procedures Relating to FACTA**

A - Employee Training

B - Defining Actions from Red Flag Identification

C - Preventing, Detecting, and Mitigating Security Breaches

D - Disposal of Records

E - IT Audits to Monitor Risk

F - Response to Address Discrepancies

G - Request for Customer Account Information

H - Reporting ID Theft



## A - Providing Designated Employees with Identity Theft Prevention Training

<p>1. Designated employees will be trained on a need to know basis according to job responsibilities.</p>
<p>2. <b>Initial Training</b> is provided on three levels:</p>
<p>1. The <b>Privacy Officer</b> attended a 1.5 day seminar regarding FACTA compliance.</p>
<p>2. <b>Privacy Committee members</b> participated in a two-hour work session on Identity Theft Prevention Program covering principles of needs assessment, program design, development, implementation and evaluation. Strategies for revision and reporting were included.</p>
<p>3. <b>Employees</b> will be trained on a need to know basis in an initial session of approximately two hours. Training will include and may not be limited to: a recap of the overall program and the utilities role; lessons in identifying and reacting to red flags; prudent steps to take to protect sensitive data; steps for reporting ID theft; ID theft vs. fraud; document disposal</p>
<p>3. <b>Annual Updates</b> will be provided for all designated employees. Sessions to be a minimum of 30 minutes will include, but not limited to the same topics as in initial training, plus possible recaps of the Privacy Committee's activities on a need to know bases.</p>
<p>4. <b>Documentation of Training</b></p>
<p>1. Training will be documented by the secretary for the Privacy Committee in the same way committee meetings are documented with minutes. For training, an agenda of the session will be included in the documentation. The agenda and minutes will be filed in the Privacy Officer's electronic FACTA files.</p>
<p>5. New employees hired into positions handling secured information will receive initial training within 30 days of employment.</p>

**B - Defining Action(s) to be taken for each of the Red Flags that relate to the opening of new accounts and the monitoring to existing accounts.**

**Procedure:**

AUB has identified the following steps to help detect, prevent and mitigate identity theft in connection with establishing accounts or servicing existing accounts.

AUB submits the follow actions relative to Red Flags. Responses may include but may not be limited to actions in the following table.

Flag	Next Step	Mitigation (Steps to Control Losses)
<b>Alerts</b>		
Consumer report indicates fraud or active duty alert.	<b>CSR notes the alert to the applicant and attempts to call the applicant via the phone number he/she provided to the CRA when requesting the alert be placed on the file.</b>	<b>If alert contact info on file with the CRA does not allow contact with the AUB applicant, CSR explains that no account can be opened until the applicant takes necessary steps with the CRA regarding contact information for creditors.</b>
Credit freeze.	<b>CSR informs applicant of the current freeze on the consumer's credit information.</b>	<b>AUB will not open an account for the subject applicant until he/she has taken appropriate steps with the CRA to lift the freeze on the report.</b>
Notice of address discrepancy from CRA.	<b>If applicant is unknown to AUB, CSR will work to obtain identification from the applicant that provides a reasonable certainty as to the applicant's identity and validity of the new address.</b>	<b>CSR reports new address, once AUB is confident, to the CRA for the purpose of records updating.</b>
Unusual patterns in activity.	<b>CSR notifies applicant of alert regarding activity.</b>	<b>If applicant is unaware of the reported activity, CSR will work with the customer at his/her will to contact the CRA so that the applicant can obtain further information.</b>
<b>Presentation of Suspicious Documents</b>		
Identification documents appear altered or forged.	<b>CSR explains to applicant that we cannot establish an account using such apparently altered/forged documents. Requests customer to return after obtaining proper documentation.</b>	<p><b>If subject document is an official government issued ID, such as DL, AUB may contact local law enforcement to alert them to the situation.</b></p> <p><b>If subject document is a "lower level" document such as a lease agreement or rent receipt, CSR may contact the landlord to discuss/verify the situation.</b></p>

Photo/physical description does not match applicant.	<b>CSR explains that a new account cannot be opened using the subject form of ID. Requests prospect to return at later time with proper ID.</b>	<b>If subject document is an official government issued ID, such as DL, AUB may contact local law enforcement to alert them to the situation.</b>
Other information on identification is inconsistent information given from applicant.	<b>CSR may raise issue to supervisor level. If the inconsistency is material in nature, AUB may reject application pending receipt of proper ID.</b>	<b>If subject document is an official government issued ID, such as DL, AUB may contact local law enforcement to alert them to the situation.</b>
Information in utility files in inconsistent with information provided. Example – signatures do not match on signature card.	<b>This type issue occurs most often regarding very old AUB information, such as old signature card that predates AUBs use of gov't ID when establishing account. Works through the issue with prospect to determine reason for inconsistency.</b>	<b>Ensure that any new account is established using current proper ID. If transaction raises level of suspicion to the point where ID theft is suspected, AUB may contact local law authorities with information.</b>
Application looks altered or forged or destroyed and reassembled.	<b>Applications are not brought in from outside, but are filled out in AUB offices.</b>	<b>NA</b>
<b>Suspicious Personal Identifying Information</b>		
Identification is inconsistent with external source such as: 1.Address v. Address on Consumer Report 2.Social security number not issued. 3.Social security number on Death Master file. 4.Inconsistent information, such as lack of correlation between date of birth and social security number.	<b>CSR informs applicant of any discrepancies and works to gain a reasonable assurance of the applicant's identity by use of alternative means, such as other forms of official ID.</b>	<b>If applicable, CSR aids applicant in contacting local SSN administration office.</b>
Identification is known to be associated with fraudulent activity: 1.The address is fictitious, a prison or a mail drop on application.	<b>If ID is <u>known</u> to be associated with fraud, AUB may contact local law enforcement.</b>	<b>AUB may notify a current customer if an applicant comes in with fraudulent info pertaining to the current customer's account, and would recommend that the customer then start the process of</b>

<p>2. The phone number is invalid or associated with a pager or answering service.</p> <p>3. The social security number is the same as that submitted by other persons opening an account.</p> <p>4. The address is the same address as that submitted by other persons opening an account.</p>		<p><b>notifying law enforcement and other pertinent entities such as their CC companies, etc.</b></p>
<p>Applicant fails to provide all personal ID requested.</p>	<p><b>CSR informs applicant that service cannot be established until required ID is presented.</b></p>	<p><b>No acct opened until ID submitted.</b></p>
<p>Personal ID is inconsistent with utility records.</p>	<p><b>AUB will initially work with applicant to understand reason for discrepancy. If fraud/theft is suspected, AUB may take mitigations steps.</b></p>	<p><b>AUB may contact local law enforcement if discrepancy indicates that ID fraud/theft is a possible motive.</b></p>
<p>For institutions using challenge questions, the person attempting to access or open the account cannot provide any information beyond what would typically be found in a wallet or consumer report.</p>	<p><b>AUB does not use challenge questions because we do not give out sensitive information over the phone, only public information.</b></p>	<p><b>NA</b></p>
<p>Change of billing address is followed by request for adding additional properties to the account (or shortly following the notification of a change in address, the utility receives a request for the addition of authorized users on the account).</p>	<p><b>CSR notifies customer that additional properties cannot be added to an additional account; new properties would require new accounts that must past scrutiny like any other. Further, to add any new names as account holders, the new holders must come to AUB and fill out application paperwork including DL info, etc.</b></p>	

Payments are made in a manner associated with fraud. For example, deposit or initial payment is made and no payments are made thereafter.	<b>In this case, account would be terminated.</b>	<b>Initial applicant would not be able to open new AUB accounts without clearing old account and without using legitimate supporting ID documentation.</b>
Existing account with a stable history shows irregularities.	<b>If this condition came to our attention, CSR may contact customer to gain understanding of issues.</b>	
Mail sent to customer is repeatedly returned.	<b>CSR may request service to attempt to verify whether location is still occupied. CSR may attempt to contact customer.</b>	<b>Account will be terminated if billings are returned unpaid.</b>
Customer notifies utility that they are not receiving their bill.	<b>CSR verifies mailing address. If same, CSR recommends customer contact USPS and to consider beginning ID theft/fraud steps.</b>	
The utility is notified of unauthorized charges or transactions in connection with a customer's account.	<b>NA to our operations.</b>	
<b>Notice of Theft</b>		
Utility is notified by law officials or others, that it has opened a fraudulent account for a person engaged in identity theft.	<b>Cooperate with law enforcements wishes.</b>	

## **C - Preventing, Detecting and Mitigating Breaches in Security**

- |                                                                                                                                                                                                                                                                                                                                                                                                                                                                      |
|----------------------------------------------------------------------------------------------------------------------------------------------------------------------------------------------------------------------------------------------------------------------------------------------------------------------------------------------------------------------------------------------------------------------------------------------------------------------|
| <ul style="list-style-type: none"><li>• In the event of a breach of security involving sensitive customer information, the following precautions will be taken to mitigate damage:<ol style="list-style-type: none"><li>1. Disconnect external connections.</li><li>2. Revoke /change access passwords.</li><li>3. Evaluate risk associated with breach.</li><li>4. Check for data integrity.</li><li>5. Load archive copy of firewall settings.</li></ol></li></ul> |
| <ul style="list-style-type: none"><li>• Notification within the utility will follow: The IT manager will notify his direct supervisor (AUB's Accounting Superintendent), the company Privacy Officer, and the General Manager.</li></ul>                                                                                                                                                                                                                             |
| <ol style="list-style-type: none"><li>3. Customers whose accounts are known to be affected by the breach will be contacted by the best available communications method to ensure timely contact, such as by phone if the number is available or USPS by using the current billing address. These customer contacts will begin with 48 hours of verification of any breach.</li></ol>                                                                                 |

## **D - Disposing of Records**

- AUB contracts with an outside vendor, Shred It, Inc., to dispose of all sensitive printed or written documentation. Locked receptacles have been placed in designated locations within the AUB offices near work areas where such information may be generated or stored, such as the customer service area and the billing/data processing area. The vendor picks up and shreds once-a-month. A certificate of shred is provided by the vendor upon request by AUB.
- Some records may be stored for reference rather than placed in the locked receptacles. For such records, AUB has records retention schedules and policies.

## **E - Conducting IT Audits to Monitor Risk for Identity Theft**

1. AUB will utilize the Identity Theft Prevention Program Checklist to audit and evaluate internal and external identity theft risk in information technology security.

- AUB will conduct walk through inspections every 4 months by the AUB IT Manager and his assistant and complete audits will be completed on a yearly basis by these same IT personnel.

The IT Manager will conduct the following checks:

Passwords are changed regularly

Physical assets are secure and accounted for

Data backlogs and restores are tested

Access logging is functional

Virus and spam filters are updated

Train and warn employees regarding spam, phishing, and other threats as well as password training.

3. Recommendations to reduce risk of identity theft will be submitted for program review and evaluation upon completion of an audit checklist. Results will be submitted to the privacy officer 2 weeks of completion of the evaluation.



## **F - Responding to Notices of Address Discrepancies**

1. <u>AUB</u> will furnish a confirmed address to a consumer reporting agency (CRA) under the following conditions:
e. Utility has established relationship with the CRA. Currently AUB does not use any CRA.
b. Utility can form a reasonable belief the consumer report relates to the consumer about whom the user request the report.
c. The consumer under review is a current customer with an active account.
d. Request involves a customer opening a new account.
e. CRA provides request ( <i>state your terms- in writing-time period</i> )

## **G - Responding to Requests for Customer Account Information**

1. AUB will furnish publically available information from utility accounts under the following conditions:
a. That the information requested is deemed public information pursuant to applicable federal and state law and in no way includes sensitive financial or identifying information, such as bank numbers, CC numbers, SSNs, gate codes, alarm codes, etc.
b. That the requested information is in no way subject to an Order of Protection and is not part of a formally established Protection Document File.
c. That the requested information is not relative to the location of a Protected establishment such as a Domestic Violence Shelter or Rape Crisis Center.

## **H -Handling Reports of Suspected Identity Theft**

<p>1. When a consumer suspects identity theft, he must notify the utility in writing, completing the Federal Trade Commission Affidavit. Instructions for completion are included as part of the form.</p>
<p>2. Customer will be asked to submit a copy of affidavit with police report to AUB's Privacy Officer.</p>
<p>3. Privacy Officer or designee will make a copy of the customer's photo ID.</p>
<p>4. Privacy Officer or designee will record the receipt of documents.</p>
<p>5. Privacy Officer or designee will, in cooperation with the customer, submit the copies of the FTC affidavit, police report and photo ID to local law enforcement.</p>
<p>6. Pertinent AUB personnel may go over the customer's account with the customer to verify all information and activity as legitimate and will change/purge information as necessary in conjunction with information provided by the customer, such as change in credit card information, etc.</p>

Effective 07/01/13

*Division of Power – Policies and Procedures Manual*  
*Standard Policies and Procedures*  
*Table of Contents*

AUB-04-01 Obtaining Electrical Service	89
AUB-04-02 Standard Electrical Service	92
AUB-04-03 Meter and Wiring Specifications	100
AUB-04-04 Underground Service	104
AUB-04-05 LED Change-out Conversions	108
AUB-04-06 Forms/Drawings/Specifications for Division of Power	111
SCHEDULE OF RULES AND REGULATIONS	131

Athens Utilities Board

<b>Division of Power – Policies and Procedures Manual</b>	
<b>Standard Policies and Procedures</b>	
<b>Policy Number – AUB-04-01</b>	<b>Revision Number: 4</b>
<b>Subject</b> <b>Obtaining Electrical Service</b>	<b>Effective Date: 10-01-2009</b>
	<b>Superintendent Approval:</b>
	<b>General Manager Approval:</b>

**1.0 PURPOSE**

The purpose of this policy is to outline the Athens Utilities Board (AUB), Division of Power requirements associated with obtaining electrical service from AUB.

**2.0 SCOPE**

This policy applies to all residential, commercial and industrial customers who are physically connected to or have the potential to be physically connected to the AUB Power Distribution System.

**3.0 REFERENCES**

- (1) Athens Utilities Board Division of Power, Rules and Regulations and Extension Policies

**4.0 GENERAL**

A formal application for original or additional service must be made at the offices of AUB or with a duly appointed agent of AUB. The application must be approved before service connection. A meter will not be set or service connected before payment of the service line installation charge and any additional applicable charges are made.

Any exceptions to this policy will be made at the sole discretion of AUB’s local control authority.

**5.0 DEFINITIONS**

- AUB** – means the Athens Utilities Board, and its duly authorized employees, agents, and representatives
- Board** – means the Chairman and all Commissioners but does not include any employees
- Customer** – Any person, business, or other entity that receives electrical service from Athens Utilities Board, Division of Power
- Division** – The Athens Utilities Board, Division of Power
- Local Control Authority** – Superintendent of Power or duly authorized representative
- kWhr** – Kilowatt-hour, the measurement by which the applicable power rate is purchased
- Service Connection** – Shall mean the point of connection between the customer’s termination point (weather head or meter center) where AUB makes the physical connection to his/her facilities.

## **6.0 PROCEDURES/POLICY**

### **6.1 Application and Contract for Service**

Each customer or prospective customer desiring original or additional electrical service shall make a formal application with an authorized employee of AUB. Applicants will supply requested information relating to the connected load, the service voltage, phase requirement, and the manner in which the service will be utilized. All applicants must sign AUB's standard form of application for service, or a general power contract.

### **6.2 Contracts**

AUB's standard form of application for service is the basic contract for all electrical service. However, large commercial or industrial customers may be requested to execute a General Power Contract containing provisions and stipulations as may be desirable to protect the interests of AUB and the customer. The use of electricity by a customer shall be interpreted as binding the customer by the terms of the applicable standard contract even though such contract may not actually be signed.

### **6.3 Customer's Obligations**

If the customer does not take the service after signing the contract, he/she shall reimburse AUB for the total expense incurred by reason of AUB's endeavor to furnish said service.

### **6.4 Building Permits**

An application for a building permit must be received by AUB prior to construction of any facilities to serve the customer, and the building permit must have been issued to the prospective customer before any service in those areas where such permits are required by governmental authority will be connected.

### **6.5 Land Development Projects**

Two copies of a developer's preliminary plat will accompany electric service applications in land development projects. Plans for distribution and service facilities will be added to the copies of the plat. The plans must be agreed upon by AUB and the developer. Affirmative action will be noted on each copy of the preliminary plat. All approved plats will be signed by the Local Control Authority or the General Manager

One copy of the plat will be attached to the Local Control Authority or the General Manager letter of certification to the Planning Commission having jurisdiction over the land development project. The other copy will be retained by AUB.

Further action by AUB will be deferred until the preliminary plat has been approved by the Planning Commission and returned to AUB with a letter of certification by the Local Control Authority or General Manager. Pending receipt of such authorization, AUB will neither authorize, accept, construct, nor connect to any utility installation under AUB's jurisdiction in a land development area.

Approval of the plans for the installation of power distribution facilities in land development projects will be certified by a letter from the Local Control Authority or General Manager to the developer following affirmative action by AUB in a regular or called meeting.

#### **6.6 Taxes**

All taxes applicable to electric service to customers of AUB shall constitute an additional charge to the amount billed.

#### **6.7 Customer Responsibility**

The customer(s) whose name(s) appear(s) on the service application shall be responsible for all charges for electric service until a notice is received at the office of AUB ordering the service disconnected. Failure to notify AUB shall not release the customer of any obligation due AUB for any service rendered or made available.

#### **6.8 Estimated Bills**

AUB reserves the right to render an estimated bill to the customer based on the best information available if the employees of AUB are unable, for any reason, to obtain access to the billing meter, if AUB has reason to doubt the registration of the meter or if an error has been discovered in the computation of the bill. AUB will either make a compensated adjustment in a later bill or will adjust the estimated bill to compensate for error if investigation of the condition, or when subsequent meter readings indicate the estimated bill was incorrect.

Athens Utilities Board

<b>Division of Power – Policies and Procedures Manual Standard Policies and Procedures</b>	
<b>Policy Number – AUB-04-02</b>	<b>Revision Number        4</b>
<b>Subject Standard Electrical Service</b>	<b>Effective Date:        10-01-2009</b>
	<b>Superintendent Approval:</b>
	<b>General Manager Approval:</b>

**1.0 PURPOSE**

The purpose of this policy is to outline Athens Utilities Board’s (AUB) standard electrical service power requirements.

**2.0 SCOPE**

This policy applies to all existing and new customers within the Athens Planning Region of Athens, Tennessee.

**3.0 REFERENCES**

- (1) Athens Utilities Board Division of Power, Rules and Regulations and Extension Policies
- (2) National Electrical Safety Code
- (3) Athens Utilities Board, Schedule of Rates and Fees
- (4) Athens Utilities Board Division of Power, Underground Service, AUB-04-05

**4.0 GENERAL**

Final review and approval of all aspects of the electrical supply system will be by the local control authority representing AUB as dictated by Reference 3-1.

Any exceptions to this policy will be made at the sole discretion of the local control authority.

Material specifications and installations shall meet the inspection and approval of the local control authority.

The entire cost and expense of installing the required electrical supply system including the connection to the existing electrical supply and including but not limited to the cost of pipe, conduit, wiring, breakers, trenching, backfilling, and services shall be borne by the developer and/or customer including the stipulated payment for connecting and metering the system to serve each lot.

**5.0 DEFINITIONS**

**AUB** – means the Athens Utilities Board, and its duly authorized employees, agents, and representatives

**Board** – means the Chairman and all Commissioners but does not include any employees

**Customer** – Any person, business, or other entity that receives electrical service from Athens Utilities Board, Division of Power

**Division** – The Athens Utilities Board, Division of Power

**Local Control Authority** – Superintendent of Power or duly authorized representative  
**kWhr** – Kilowatt-hour, the measurement by which the applicable power rate is purchased  
**Service Connection** – Shall mean the point of connection between the customer’s termination point (weather head or meter center) where AUB makes the physical connection to his/her facilities.

## **6.0 POLICY/PROCEDURES**

### **6.1 Residential Customers**

Standard residential electric service shall be single-phase, 120/240 volt, three-wire service. Customers have the option of requesting three-phase service on the premises in question. Customers desiring three-phase, four-wire, 120/240 volt, or 120/208 volt, service on a single meter for all residential requirements shall pay the difference between all AUB’s expense of providing single-phase service and the expense of providing three-phase service.

AUB will require the customer to execute an Aid of Construction Agreement for incremental costs of providing three-phase service in cases where three-phase electric service is not readily available.

A combined load of single-phase and three-phase may be served at 120/240 volts, or 120/208 volts, depending on the location. AUB reserves the right to require that such service be 120/208 volts when the single-phase load totals more than 25 kW regardless of location.

AUB may require the customer to enter into an Aid of Construction Agreement in cases where electric service is not readily available.

Customers desiring electric service at voltages exceeding 240 volts will be considered individually.

### **6.2 Commercial Customers**

Single-phase service is not available for commercial customers that use between 50 to 100 kW. Single-phase loads will be divided among the phases of a 120/208-volt service. A combined load of single-phase and three-phase, where the single-phase part of the load does not exceed 25 kW, may be served at 120/240 volts, three-phase, four-wire configurations.

AUB will consider commercial customers individually when the customer’s demand exceeds 100 kW. AUB shall be under no obligation for commitments or investments by the customer made prior to agreement of service conditions.

### **6.3 Motor Loads**

Customers desiring motor applications should obtain information concerning the types of service available from AUB in the immediate area.

#### Single-Phase Motors

Motors of five horsepower (HP) and smaller may be started across the line, provided such starting does not cause undue interferences to other customers served from the same transformer. On equipment containing two or more motors exceeding five HP in total, the controls should be connected and operated so that motors will not be started simultaneously.



Any single-phase motor of 10 HP rating and smaller whose starting characteristics limit the locked rotor current to 300% of full-load current may be started across the line. Single-phase motors larger than 10 HP will be considered as special applications and will be served only when the customers meet the requirements of AUB.

#### Three-Phase Motors

Motors 15 HP and smaller operated singly may be started across the line. Controls should be connected and operated so that motors will not be started simultaneously on equipment containing two or more motors exceeding 15 HP.

Motors larger than 15 HP up to and including 75 HP, must be equipped with starting devices to limit the locked rotor current to 300% of full load current.

Motors in excess of 75 HP, up to and including 100 HP, must be equipped with starting devices to limit the locked rotor current to 250% of full load current.

Motors in excess of 100 HP shall be considered a special application and will be served only when the customer meets AUB's requirements for the application.

All exceptions to these policy requirements must have written approval from the local control authority.

### **6.4 Temporary Service**

Customers shall provide a suitable meter pole, or other structure, with entrance conductors, meter sockets, and protective devices properly installed for connection with AUB's service line. Such pole, or structure, shall have sufficient height and mechanical strength to support the overhead or underground service line. The complete temporary service installation shall meet all requirements of the National Electrical Safety Code, the National Electric Code, and local regulations. (See Specification Drawing OH-3).

The location of the temporary service connection will be determined by a duly authorized employee of AUB, and all costs incidental to relocating a temporary service connection for the convenience of the customer shall be at the customer's expense.

The customer will specify the date and period of time temporary service will be needed.

### **6.5 Outdoor Lighting**

AUB will own, install and maintain all facilities required for outdoor lighting service under Part B of the Rate Schedule LS in AUB's Schedule of Rates and Fees. The customer shall, by signing the application for outdoor lighting, agree to a 1 year contract.

Any relocation costs shall be borne by the customer.

Customers with outdoor lighting service requirements other than the standard wooden pole and overhead service will be eligible for participation in the Lease Lighting Program.

Mutual agreement of the customer and an authorized representative of AUB shall select the location of the light(s). The light and pole location must be no more than 15 feet from the driveway or graveled road.

#### **6.6 Mobile Homes**

Service for mobile homes shall be limited to single-phase, 120/240 volts unless covered by special contract. AUB may require the customer to enter into an Aid of Construction Agreement prior to construction in cases where electric service is not readily available.

The location of the temporary service connection will be determined by a duly authorized employee of AUB, and all costs incidental to relocating a mobile home service for the convenience of the customer shall be at the customer's expense.

An electrical inspection will be required for the meter and/or service entrance installation prior to initiation of service (See Specification Drawings OH-4).

#### **6.7 Mobile Home Courts**

AUB will install overhead distribution facilities throughout the court based on the most economical design with overhead service lines to metering poles. The mobile-home court owner will own, install and maintain a wiring system connecting the point of delivery located on the meter poles with each mobile home. Installation will include meter sockets and protective devices for each mobile home position grouped such that a minimum of four mobile homes and a maximum of eight mobile homes may be served from a single metering pole. Such wiring system should be adequate to maintain standard voltage to each mobile home, and delivery of electric service at the metering point of voltage within commercial limits shall constitute delivery of electric service for the purpose of this section.

AUB may require the customer to enter into an Aid of Construction Agreement prior to construction in cases where additional facilities are needed.

Underground service is available provided the system is installed as per underground regulations.

#### **6.8 Discontinuance of Service by AUB**

AUB shall have the right to terminate service to any customer for violation of any provision of the Rules and Regulations, Contract for Service, or the requirements listed in this policy. The right to discontinue service will apply to all services received through the account involved although more than one customer may receive service therefrom.

Discontinuance of service by AUB, for any cause, shall not release the customer's responsibility for payment for service already received, from liability for payments that may become due under the Minimum Bill Provision, or other provisions of the Application for Service or contract.

## **6.9 Termination of Service by Customer**

Any customer may request service discontinuance at any time. Termination of service for any reason shall not relieve the customer of any obligation due AUB under the terms of the service agreement or contract.

Only the person in whose name the account is carried may order service discontinued. In the event the customer(s) in whose name(s) the account is carried does not occupy the premises and service is ordered discontinued by the customer, AUB reserves the right to permit the occupant of the premises to apply for service at that location. The occupant will then become responsible for all obligations for service rendered at the location. Under no circumstances will AUB become a party to owner-occupant relationships, AUB shall consider each as individual customers or applicants.

## **6.10 Rights of Ingress and Egress**

Upon identification, AUB employees, agents and representatives shall have access to the customer's premises at any time for the purpose of installing, removing, operating, maintaining, inspecting, testing, replacing, or repairing any equipment or facilities owned, operated, or maintained by AUB.

## **6.11 Easement Rights**

Customers shall grant, at no cost to AUB, adequate easement rights for any and all such facilities to provide service at the location requested. It shall be the customer's responsibility to observe and preserve AUB's easement rights required for rendering service at the requested location.

## **6.12 Notice of Trouble**

It will be the customer's responsibility to immediately notify AUB should the service be unsatisfactory or interrupted, or in the event of any defects, trouble, accidents, or interruption affecting the supply of electrical energy.

## **6.13 System Disturbances**

Electric service shall not be used in a manner that causes unusual voltage fluctuations or disturbances on AUB's system. The customer may be required to install, at his/her own expense, such apparatus or equipment that will limit fluctuations and disturbances. The need and the extent of corrective measure shall be determined by AUB.

## **6.14 Load Balance**

The customer shall exercise reasonable care to maintain a load balance, especially during periods of maximum or near maximum loads. AUB will, within reasonable limits, require that current taken from each phase conductor of the customer's electric service be reasonably balanced.

## **6.15 Added or Increased Loads**

The transformers, meters, and service equipment supplied by AUB have rated capacities. It shall be the customer's responsibility to notify AUB of any addition to the electrical requirements in advance. Failure to notify AUB of such major additions or increase in electrical requirements shall render the customer liable for any injury or damage to persons or property caused by additional loads.

## **6.16 Interruption of Service**

AUB will endeavor to supply continuous electric service at a reasonably constant voltage. However, AUB cannot guarantee uninterrupted service or any fixed voltage. In the construction, operation, and maintenance of the electric system, AUB shall have the right to temporarily interrupt electric service to any customer, or group of customers, when interruption is necessary for the safety of employees or the public.

## **6.17 Customer's Responsibility for AUB's Property**

The customer shall provide a space for and shall exercise proper care to protect, AUB property on his/her premises. In the event of loss or damage to AUB's property arising from neglect of the customer, the customer shall reimburse AUB for all costs of necessary repairs and/or replacement.

## **6.18 Resale Service**

All electrical energy used on the customer's premises, other than emergency or stand-by service, shall be supplied exclusively by AUB. The customer shall not directly or indirectly dispose of the electrical energy to any other person or premises.

## **6.19 Unauthorized Operation of AUB's Equipment**

No person shall operate nor attempt to operate, repair, maintain, or remove, any of AUB's facilities or equipment unless directed to do so by AUB under emergency conditions. The customer assumes all liability and responsibility and renders him/herself subject to prosecution should he/she participate in, or permit, authorize, or direct the violation of the terms of this policy.

## **6.20 Curtailment**

AUB reserves the right to restrict the purposes for, and the amount of, electricity used by a customer during times that may be necessary.

## **6.21 Service Lines**

### **6.21.1 Overhead Service Lines**

The customer shall own, install and maintain all wiring and associated equipment on the load side of the delivery point with the exception of AUB's meters which shall be owned and maintained by AUB.

The location of the meter center and the point of delivery shall be designated by an authorized employee of AUB. AUB reserves the right to decline service to any point or installation which has not been approved by a duly authorized employee. The location will be at a point that would permit AUB to serve the customer efficiently and economically. The cost of providing service at a different location will be shared by the customer and AUB. The customer will reimburse AUB for the actual cost of the additional materials required. AUB will assume the additional cost of labor. Architects, engineers, and contractors should obtain this information prior to preparation of building plans, proposals and bids.

The customer will provide, own, install, and maintain a point of attachment of sufficient height and mechanical strength to support AUB's overhead service line. Where service masts are required, no joint will be permitted in the vertical section within 10 feet of the point of attachment.

Service entrance leads shall extend a minimum of three feet beyond the weatherhead for sizes No. 2 AWG and smaller; four feet for sizes No. 1/0 AWG – 500 MCM; and six feet for sizes larger than 500 MCM.

Metering equipment shall be located outside of the building, be readily accessible at all times and placed in a location that will not subject it to accidental damage, with a minimum clearance from obstructions of 12 inches on either side, above and below the meter, and 36 inches in front of the meter. The meter center shall be mounted by the customer on a vertical surface in a manner such that the meter shall not be tilted in any direction (See Specification Drawing OH-1 and OH-2).

### **6.21.2 Underground Service Lines**

The customer shall install, to AUB's specification (See Drawings UG-1, UG-2, and UG-3), conduit from the point of demarcation to the customer's meter center. AUB will own, install, and maintain all facilities from the service connection to the AUB overhead system or distribution transformer.

The meter center shall be located at a point designated by AUB. On residential services, AUB shall install all conductors from the meter center to the connection with the overhead system or the distribution transformer. Where CT metering is required, the customer's conduit and wiring shall continue to the point of connection to the overhead system or the distribution transformer.

All underground electrical services shall conform to the requirements as listed in AUB Underground Service Policy, AUB-04-04.

All meters, service connections, and other equipment furnished by AUB are and shall be the property of AUB. The customer shall provide a space for, and exercise proper care to protect, the property of AUB on his/her premises. In the event of loss or damage to AUB's property arising from customer neglect, the customer shall pay the cost of repairs or replacements.

Existing 400 amp or less pole metered or CT metered residential services that must be replaced or upgraded shall require the customer to install a new meter center on the structure and meet all current standards.

### **6.22 Non-Standard Service**

Any type of service not described in the preceding sections of this policy shall be considered non-standard and the customer shall confer with AUB regarding the form and type of service requested.

The customer shall contact AUB prior to purchasing any equipment related to non-standard electric service. AUB will furnish information of the character of service available, the location of facilities, and the ability of AUB to meet special requirements. Nothing contained herein shall obligate AUB to provide special services. The customer shall pay the costs of any special installation made to meet his/her special requirements for non-standard service or for the supply of closer voltage regulation than required by standard practice.

Services listed below are considered non-standard:

1. Commercial customers with a total demand not exceeding 50 kW desiring electric service at voltages exceeding 240 volts.
2. Individual motors in excess of 100 H.P.
3. Appliances requiring relatively close voltage regulation.
4. Residential services over 400 amps.

Athens Utilities Board

<b>Division of Power – Policies and Procedures Manual</b>	
<b>Standard Policies and Procedures</b>	
<b>Policy Number – AUB-04-03</b>	<b>Revision Number: 4</b>
<b>Subject</b> <b>Meter and Wiring Specifications</b>	<b>Effective Date: 10-01-2009</b>
	<b>Superintendent Approval:</b>
	<b>General Manager Approval:</b>

**1.0 PURPOSE**

The purpose of this policy is to outline the meter and wiring specification policy for the Athens Utilities Board (AUB).

**2.0 SCOPE**

This policy applies to all existing and future power accounts serviced by AUB.

**3.0 REFERENCES**

- (1) Athens Utilities Board, Division of Power, Rules and Regulations and Extension Policies
- (2) National Electrical Safety Code of the National Board of Fire Underwriters as approved by the American Standards Association
- (3) State of Tennessee Department of Insurance and Banking
- (4) National Electrical Safety Code
- (5) TCA 65-35-101 through 107

**4.0 GENERAL**

Future connections to the Athens Power Distribution System are required to be coordinated through the local control authority for AUB. All policy requirements listed in **Section 6.0** are applicable to new electrical connections.

**5.0 DEFINITIONS**

**AUB** – means the Athens Utilities Board, and its duly authorized employees, agents, and representatives

**Board** – means the Chairman and all Commissioners but does not include any employees

**Customer** – Any person, business, or other entity that receives electrical service from Athens Utilities Board, Division of Power

**Division** – The Athens Utilities Board, Division of Power

**Local Control Authority** – Superintendent of Power or duly authorized representative

**kWhr** – Kilowatt-hour, the measurement by which the applicable power rate is purchased

**Service Connection** – Shall mean the point of connection between the customer’s termination point ( weather head or meter center) where AUB makes the physical connection to his/her facilities.

## **6.0 POLICY/PROCEDURES**

### **6.1 Meter Installation and Removal**

All meters and metering equipment shall be owned and maintained by AUB. Only authorized employees of AUB shall be permitted to install, seal, unseal, adjust, connect, disconnect, remove, or relocate any meter or metering device installed for the purpose of measuring electrical energy. The customer shall not permit any work to be done, or any device to be installed, which would in any manner effect the proper registration of any electric meter. Any unauthorized work done, or device installed, when discovered by AUB, shall constitute a violation of the service policies and procedures for the Division of Power and are subject to service termination by AUB. All persons are cautioned against tampering with the meter or its associated facilities. Individuals will be prosecuted to the full extent of codes TCA 65-35-101 through 107 if found guilty of tampering.

### **6.2 Self-Contained Meters**

All services of 400 amps and less will normally be metered with self-contained meters. An approved meter center will be furnished and installed by the customer at a point designated by AUB. All maintenance, parts and repairs of the meter center shall be the customer's responsibility.

In the event the electrical requirements of the customer are increased above the rated capacity of self-contained metering equipment, the customer shall install a proper service entrance for CT type metering at no cost to AUB.

### **6.3 Instrument Transformer Meters**

All services of more than 400 amps will normally be metered with CT type meters. AUB will furnish and install all facilities for CT type metering.

### **6.4 Meter Tests**

AUB will, at its own expense, make such tests and inspections as may be required on its meters and metering equipment to ensure a high standard of accuracy. AUB will make additional tests or inspections of its meters requested by the customer. No adjustment will be made to the customer's bill, and a test charge will be paid by the customer if such tests indicate the meter registration is within two percent. In the event the test indicates the registration is in excess of two percent, an adjustment will be made to the customer's bill for the legal remedy allowed (three years) and the costs of making such tests shall be borne by AUB.

### **6.5 Separate Metering Facilities**

Separate metering facilities shall be provided for each customer, type of service or service classification for each building, structure, or premise.



## **6.6 Wiring Standards**

All equipment and facilities of the customer installed for the use or transmission of electrical energy shall comply with: 1) the requirements and specifications of the National Electrical Safety Code of the National Board of Fire Underwriters as approved by the American Standards Association; 2) the requirements of the State of Tennessee Department of Insurance and Banking; 3) municipal ordinances or regulations as they may apply; and 4) the requirements of AUB. In the event of conflict, the above named authorities shall govern in the order named.

## **6.7 Protective Equipment**

The customer shall be responsible for and shall provide protective equipment necessary to protect his/her own equipment. If three-phase equipment is connected, it is the customer's responsibility to protect against phase failure.

AUB will install protective equipment that, in its opinion, is required to protect only its own facilities.

## **6.8 Inspections**

A certificate of approval shall be required for all new connections or reconnections to new, remodeled, reconstructed, rewired, or relocated buildings, services that have been disconnected for over 6 months, structures, trailers, mobile homes, or premises either permanent or temporary in nature not already approved for electric service before AUB will connect to the customer's wiring. Such certificate of approval shall be issued by an electrical inspector approved by the State of Tennessee Department of Insurance and Banking, or by an authorized municipal electrical inspector.

AUB reserves the right to decline service to any installation when AUB has reason to believe the wiring is hazardous or does not comply with the requirements listed in *Section 6.6*. In the event AUB declines to maintain or restore service, AUB will pay the inspection cost in those cases where such inspection reveals no hazardous or defective wiring and complies with the aforementioned authorities.

A certificate of approval or a written release issued by the inspector shall be required for any building, structure, or premise on which AUB has received a notice of condemnation before electric service may be provided.

In cases of emergency, electric service may be connected after an Emergency Service Order has been signed by an authorized person, assuming all responsibility and liability for any damages or injuries resulting directly or indirectly from the connection of AUB's facilities to such installation. The customer shall provide a certificate of approval or service shall be discontinued pending a receipt of certificate of approval at the offices of AUB.

## **6.9 Grounding**

The grounding conductor shall meet NEC requirements. It shall extend in one continuous run from the weatherhead, or point of delivery, to the grounding electrode. A lead shall be left at the weatherhead, or point of delivery, of equal length as the service entrance conductors. It shall be installed so the service entrance will provide protection against mechanical injury. There shall also be a ground conductor installed from the grounding terminal inside the meter center to the continuous ground conductor bonded with an approved bonding clamp. Where metallic conduit is used, the grounding conductor shall be outside the conduit and bonded to each joint of the conduit above the meter center and immediately below the meter center with approved bonding clamps.

The grounding electrode shall be a driven rod, and at least 18 inches from the foundation of the building, structure or service pole where practical and shall not be set at an angle which would cause the rod to be driven under the building or structure into dry soil. The grounding conductor shall not be “jumped” from the building, or structure, to the electrode but shall go down adjacent to the foundation to not less than 6 inches underground and then over to the electrode. All connections shall be made with approved clamps.

Requirements for grounding for temporary services shall be the same as those required for permanent service.

## **6.10 Interconnections**

No interconnections of any type shall be permitted between the AUB electric system and any other source of electrical energy except through written consent of AUB.

Athens Utilities Board

<b>Division of Power – Policies and Procedures Manual Standard Policies and Procedures</b>	
<b>Policy Number – AUB-04-04</b>	<b>Revision Number: 4</b>
<b>Subject Underground Service</b>	<b>Effective Date: 10-01-2009</b>
	<b>Superintendent Approval:</b>
	<b>General Manager Approval:</b>

**1.0 PURPOSE**

The purpose of this policy is to standardize Athens Utilities Board’s (AUB) approach to the installation of underground electrical service.

**2.0 SCOPE**

This policy applies to all new and existing customers purchasing electrical energy from AUB.

**3.0 REFERENCES**

- (1) Athens Utilities Board, Division of Power, Rules and Regulations and Extension Policies
- (2) Athens Utilities Board, Division of Power, Meter and Wiring Policy, AUB-04-03
- (3) National Electrical Safety Code

**4.0 GENERAL**

No person shall install or attempt to install underground service that utilizes electrical energy supplied by AUB’s Division of Power using piping or equipment that are not specifically approved by AUB in this policy or Policy AUB-04-03, Meter and Wiring Extension Policy.

**5.0 DEFINITIONS**

**AUB** – means the Athens Utilities Board, and its duly authorized employees, agents, and representatives

**Board** – means the Chairman and all Commissioners but does not include any employees

**Customer** – Any person, business, or other entity that receives electrical service from Athens Utilities Board, Division of Power

**Division** – The Athens Utilities Board, Division of Power

**Local Control Authority** – Superintendent of Power or duly authorized representative

**kWhr** – Kilowatt-hour, the measurement by which the applicable power rate is purchased

**Service Connection** – Shall mean the point of connection between the customer’s termination point (weather head or meter center) where AUB makes the physical connection to his/her facilities.

## 6.0 POLICY/PROCEDURES

The following are general requirements for the installation of underground electrical service that apply to residential and commercial customers as specified in *Sections 6.1* and *6.2* of this policy.

1. The meter center shall be mounted securely to a vertical surface so the meter will not be tilted in any direction. It will be located so it will not be subjected to accidental damage and shall have a minimum 12-inch clearance from obstructions on either side, above and below the receptacle, and 36 inches in front.
2. The center of the meter shall be no less than five feet or more than six feet above **finished grade**. Grading and/or fill **must be completed before the meter will be installed**.
3. The meter center shall be utilized as a meter receptacle only, and shall not be utilized for any other purpose, (e.g., a junction box, etc.)
4. Metallic conduits shall be bonded to the ground conductor with approved bonding clamps.
5. All conduit ends shall be free of any burrs and sharp or rough surfaces and shall be equipped with bushings to protect the conductors. Seals are recommended NEC 300-5 (g).
6. Conduits shall be secured to the structure within 12 inches of the meter center and within six inches above final grade.
7. The ground conductor shall be bare copper and shall extend in one continuous piece from the meter center to the ground electrode and shall be installed adjacent to the conduit under the conduit straps. (Aluminum, copper-clad aluminum or steel conductor is not acceptable by AUB.)
8. The grounding electrode shall be a driven rod, and at least 18 inches from the foundation of the building or structure where practical and shall not be set at an angle which would cause the rod to be driven under the building or structure into dry soil. The grounding conductor shall not be “jumped” from the building, or structure, to the electrode but shall go down adjacent to the foundation to not less than 6 inches underground and then over to the electrode. All connections shall be made with approved clamps.

*Drawing UG-1* represents an AUB-approved residential underground electrical service connection. AUB reserves the right to decline service to any installation where the location and/or method of installation has not been approved by an authorized employee of AUB. All costs incidental to relocating a service entrance installation shall be at the customer’s expense.

The developer or customer shall furnish and install primary and secondary conduits according to AUB specifications. The customer will convey title of these facilities to AUB before the installation is energized. Materials specified may vary according to location, type of service, and technique development. The most economical method may be neither desirable nor practical in some situations, in which cases the final decision shall rest with AUB.

## 6.1 Residential

Underground electrical service will be provided when the following conditions have been met:

1. Primary conduit sized, designed and specified by AUB is installed to AUB specifications. AUB will then install primary cable and operate and maintain the primary system. (See Specification Drawing UG-3)
2. On services where underground primary has been installed, the customer will be required to install a three-inch conduit from the meter center on the house to AUB's transformer. This conduit run shall consist of one, ninety-degree turn below the meter center. Any other turns needed will be sweeps. The conduit shall be Schedule 40 PVC and be buried at a minimum depth of 30 inches. All conduit and fittings that extend above finished grade shall be Scheduled 80 PVC. All joints shall be glued together. A ¼-inch pull rope of continuous length shall be installed inside the conduit. AUB will install the service conductor to the house inside the conduit and make the appropriate connections at the meter center and transformer. (See Specification Drawing UG-1 Sheet 1)
3. If the service is across the street from the transformer, AUB will stub out under the street with three-inch PVC and the customer will connect to the stub. AUB will stub out from the transformer, and the customer will be required to attach at this point on services on the same side of the street. AUB will run the service conductor from the transformer to the house and make the appropriate connections when needed. (See Specification Drawing UG-1 Sheet 3)
4. If the customer's service is from an overhead line, he/she will be required to run three-inch conduit from the meter center to the base of the pole and extend the conduit 30 to 36 inches above ground level. AUB will attach to the customer's conduit and extend up the pole to the required height and run the service conductor at no cost. (See Specification Drawing UG-1 Sheet 2)
5. All conduit installations **will** be inspected **prior** to back-filling for proper depth and material used. AUB personnel will do this only during normal business hours. If the ditch is backfilled before inspection, the customer will be required to uncover conduit at locations determined by AUB.
6. The AUB Engineering Department shall determine all AUB meter center locations. Meter centers are preferred to be located on the side of the house closest to the transformer. If a meter center is located in the back of the house, it should not be more than 10 feet from the corner of the house or additional charges may be incurred.
7. Underground-fed security lights shall be installed within 15 feet of a driveway or graveled roadway. The conduit system feeding these lights shall be installed by the customer to AUB specifications.
8. Facilities will be installed in accordance to all applicable codes. Installation of primary conduit and transformers will be such that all applicable depths and clearances will be met after all areas are at final grade. Any relocation, repair or re-installation of any facilities after the initial installation will result in an additional

payment for actual work done. This will be charged to the person or persons responsible and could result in a delay of service.

9. The installation of the underground primary, secondary crossings and service conduits should precede any paved covering or any landscaping. Failure to install the underground electric conduit prior to construction of any roads or landscaping may result in additional costs being billed to the contractor/owner
10. AUB will assume ownership of the conduit system after the service has been energized. This does not include the ditch in which it lies.

## **6.2 Commercial and Industrial**

1. Underground electrical facilities will be installed at no cost for commercial and industrial customers provided there is sufficient load to justify the cost of providing a pad mount transformer.
2. All service entrance conductors from AUB's transformer to the customer's main panel will be owned, installed and maintained by the customer.
3. All primary conduits of underground service shall be installed by the customer and maintained by AUB.
4. A final site plan and load sheet will be provided to AUB prior to any electrical facilities being installed. The location of all transformers, conduits, cable, etc., shall be determined by AUB and agreed upon by the contractor prior to installation. Any relocation, repair or reinstallation made necessary by changes after the initial installation of AUB facilities will result in the associated costs being charged to the contractor/owner and payable prior to final service.
5. The customer will construct a concrete pad to AUB's specifications at the agreed upon location including all necessary primary and secondary conduits being stubbed out.
6. The feasibility of underground electrical facilities shall be based on soil and terrain conditions as determined by AUB's Engineering Department.

Athens Utilities Board

<b>AUB Policies and Procedures Manual</b>	
<b>Standard Policies and Procedures</b>	
<b>Policy Number – AUB-04-05</b>	<b>Revision Number: 1</b>
<b>Subject</b> <b>LED Change-out/Conversions</b>	<b>Effective Date: 03-01-2016</b>
	<b>Superintendent Approval:</b>
	<b>General Manager Approval:</b>

**1.0 Purpose**

Based on the energy efficiency and long life of LED lighting, AUB is committed to converting Mercury Vapor (MV) and High Pressure Sodium (HPS) security and street lights over to LED fixtures. This policy outlines the AUB’s decision matrix and steps to transition current outdoor lighting for individual customers from traditional type lights to more efficient LED fixtures and components.

**2.0 Scope**

AUB has six LED outdoor lights available for individual customers under Part B of the Outdoor Lighting Rate – Schedule LS, dated October 2015.

The lights offered include:

- 64 watt LED open bottom fixture
- 72 watt LED decorative fixture
- 216 watt LED cobra head fixture
- 216 watt LED Flood light fixture
- 284 watt LED cobra head fixture
- 284 watt LED Flood light fixture

AUB will no longer offer HPS lights for new installations. In general, only LED or metal halide (MH) lights will be offered for new installations.

Customers requesting lights, fixtures, or poles not offered under Part B of Schedule LS may be accommodated through and in accordance with AUB’s leased lighting program. These requests will be considered individually.

**3.0 General**

**3.1 Normal Conversion Procedure – Security Lights**

AUB will convert traditional MV and HPS customer security lights with an appropriate LED fixture as the traditional bulbs or fixtures fail in the follow manner:

- 175-watt MV open-bottom and 100-watt HPS open-bottom fixtures will be replaced with a 64-watt open-bottom LED fixture
- 100-HPS Decorative fixtures will be replaced with a 72-watt Decorative LED fixture
- 250-watt HPS, 400-watt HPS, or 400-watt MV security lights, whether they are cobra-head or flood type lights, will be replaced with a corresponding LED fixture only when the fixture fails.

There will be no charge for the conversion under the conditions described above.

However, if it is determined that a bulb or fixture failure for any security light was the result of vandalism such as a gunshot or other malicious behavior, the security light in question will be replaced in kind (e.g., with another 100-watt HPS bulb or fixture) or pursuant to section 3.2 “Change-out At Customer Request” below if the customer wants an LED to replace the damaged fixture.

Metal Halide (MH) bulbs and fixtures will be replaced in kind.

### **3.2 Change-out At Customer Request – Customer Security Lights**

For residential accounts, if the customer requests that AUB change out an existing, working security light to an LED security light there will be a \$100 change-out fee regardless of the age of the light.

If there are multiple lights at the account and the customer would like those changed out also then there will be an additional charge of \$20 per light changed out.

There will be no change-out fee for changing a 175 MV security light to an LED equivalent.

For commercial accounts, if the customer requests that AUB change out an existing, working security light to an LED security light there will be a stranded-cost recovery charge and labor charge.

The stranded-cost recovery charge will be based on the depreciated value of the installed cost of the light. Depreciation is figured at ten (10) percent. The labor charge will be the calculated AUB labor cost for removal of the old light(s) and installation of the new light(s).

### **3.3 Street Light Conversion**

AUB is converting failed HPS and MV street lights to LED lights.

175-watt MV open bottom street lights, 100-watt HPS open-bottom street lights, and 100-watt Decorative street lights will be converted to the appropriate LED light when a bulb or fixture fails.

AUB will convert traditional MV and HPS city street lights with an appropriate LED fixture as the traditional bulbs or fixtures fail in the follow manner:



- 175 MV open bottom and 100 HPS open bottom will be replaced with a 60-watt LED cobra head fixture
- 100 HPS decorative street lights will be replaced with a 72-watt LED decorative fixture

All of these lights will have an R3 light distribution pattern.

250-watt HPS street lights, 400-watt HPS street lights, and 400-watt MV street lights will be replaced with equivalent LED fixtures only when the fixture fails.

- 250-watt HPS cobra head will be replaced with a 215-watt LED cobra head
- 250-watt HPS flood light will be replaced with a 215-watt LED flood light
- 400-watt HPS and MV cobra head will be replaced with a 284 watt LED cobra head
- 400 HPS or 400 MV flood light will be replaced with a 284 watt LED flood light

All of these lights will have an R3 light distribution pattern.

#### **4.0 Definitions**

**AUB** – means the Athens Utilities Board, and its duly authorized employees, agents, and representatives

**Customer** – Any person, business, or other entity that receives electrical service from Athens Utilities Board, Division of Power

**LED** – Light Emitting Diode

**MV** – Mercury Vapor

**HPS** – High Pressure Sodium

AUB-04-06  
Forms/Drawings/Specifications  
For Division of Power



### **OVERHEAD SERVICE MAST**

1. The meter center shall be mounted securely to a vertical surface such that the meter will not be tilted in any direction, located such that it will not be subjected to accidental damage, and shall have minimum clearances from obstructions of 12 inches on either side, above and below the receptacle and 36 inches in front.
2. The center of the meter shall be no less than 5 feet, or more than 6 feet above finished grade. Grading and/or fill must be completed before the meter will be installed.
3. The meter center shall be utilized as a meter receptacle only, and shall not be utilized for any other purpose -- junction box, etc.
4. The weatherhead on the service mast shall not be less than 42 inches above the roof. Where necessary to attach the service drop to the service mast at a point more than 42 inches above the roof line, to comply with other clearance requirements or other reasons, guying will be required as specified by AUB.
5. The service entrance conductor leads shall extend a minimum of 36 inches from the weatherhead of sizes No. 2 AWG and smaller, four feet for sizes 1/0 thru 500 MCM; and six feet for sizes larger than 500 MCM.
6. The uppermost 10 feet of the metallic service mast shall be continuous without sleeve, fitting, or joint of any type.
7. Each metallic conduit joint shall be bonded to the ground conductor with approved bonding clamp at the weatherhead.
8. The ground conductor shall meet NEC requirements, and shall be one continuous piece from the grounding electrode to the weatherhead and shall extend the same length as the service wires from the weatherhead. It shall be installed adjacent to the conduit, under the conduit straps, and outside the meter center. There shall also be a ground conductor installed from the grounding terminal inside the meter center to the continuous ground conductor bonded with an approved bonding clamp. (Aluminum, copper-clad aluminum, or steel conductor not acceptable by AUB.)
9. The grounding electrode shall be a driven rod, and at least 18 inches from the foundation of the building or structure where practical and shall not be set at an angle which would cause the rod to be driven under the building or structure into dry soil. The grounding conductor shall not be "jumped" from the building, or structure, to the electrode but shall go down adjacent to the foundation to not less than 6 inches underground and then over to the electrode. All connections shall be made with approved clamps.
10. Each installation shall meet all requirements of the National Electric Code (NEC), National Electric Safety Code (NESC), and any other applicable codes, regulations, or

requirements of authorities having jurisdiction as would be required for permanent service.

11. Athens Utilities Board reserves the right to decline service to any installation where the location and/or method of installation have not been approved by an authorized employee of AUB. All costs incidental to adding, relocating, and/or re-routing AUB facilities shall be at the customer's expense.

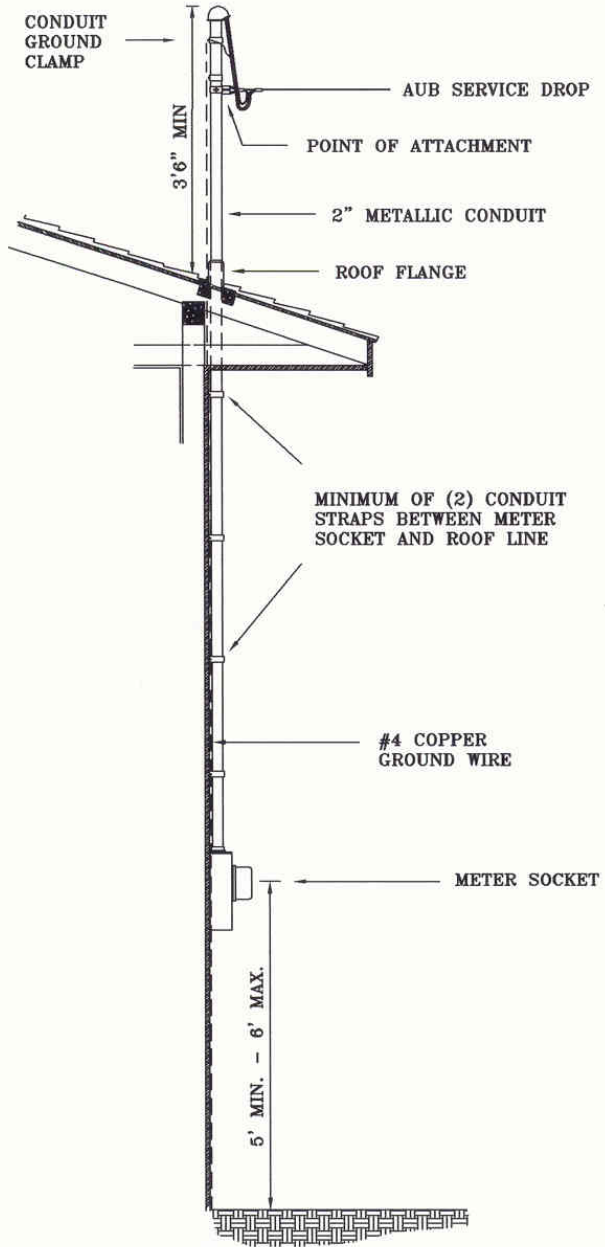

APPROVED:  
 \_\_\_\_\_  
 REVISED DATE:  
 \_\_\_\_\_

**OVERHEAD  
 SERVICE MAST**

ATHENS UTILITIES BOARD  
 ATHENS, TENNESSEE  
 DWG: OH-1

### **OVERHEAD SERVICE ATTACHED TO STRUCTURE**

1. The meter center shall be mounted securely to a vertical surface such that the meter will not be tilted in any direction, located such that it will not be subjected to accidental damage, and shall have minimum clearances from obstructions of 12 inches on either side, above and below the receptacle and 36 inches in front.
2. The center of the meter shall be no less than 5 feet, or more than 6 feet above finished grade. Grading and/or fill must be completed before the meter will be installed.
3. The meter center shall be utilized as a meter receptacle only, and shall not be utilized for any other purpose -- junction box, etc.
4. The point of attachment for the overhead service shall be installed at a height to be determined by an AUB representative, meeting clearance requirements established by the NESC.
5. The customer shall provide a point of attachment which shall be a 5/8" machine bolt and eye-nut or 5/8" eye-bolt mounted through a header, plate, etc. of sufficient strength to support the service drop.
6. The service entrance conductor leads shall extend a minimum of 36 inches from the weatherhead of sizes No. 2 AWG and smaller, four feet for sizes 1/0 thru 500 MCM; and six feet for sizes larger than 500 MCM.
7. The grounding electrode shall be a driven rod, and at least 18 inches from the foundation of the building or structure where practical and shall not be set at an angle which would cause the rod to be driven under the building or structure into dry soil. The grounding conductor shall not be "jumped" from the building, or structure, to the electrode but shall go down adjacent to the foundation to not less than 6 inches underground and then over to the electrode. All connections shall be made with approved clamps.
8. The ground conductor shall meet NEC requirements, and shall be one continuous piece from the grounding electrode to the weatherhead and shall extend the same length as the service wires from the weatherhead. It shall be installed adjacent to the conduit, under the conduit straps, and outside the meter center. There shall also be a ground conductor installed from the grounding terminal inside the meter center to the continuous ground conductor bonded with an approved bonding clamp. (Aluminum, copper-clad aluminum, or steel conductor not acceptable by AUB.)
9. Each installation shall meet all requirements of the National Electric Code (NEC), National Electric Safety Code (NESC), and any other applicable codes, regulations, or requirements of authorities having jurisdiction as would be required for permanent service.
10. Athens Utilities Board reserves the right to decline service to any installation where the location and/or method of installation have not been approved by an authorized employee

of AUB. All costs incidental to adding, relocating, and/or re-routing AUB facilities shall be at the customer's expense.



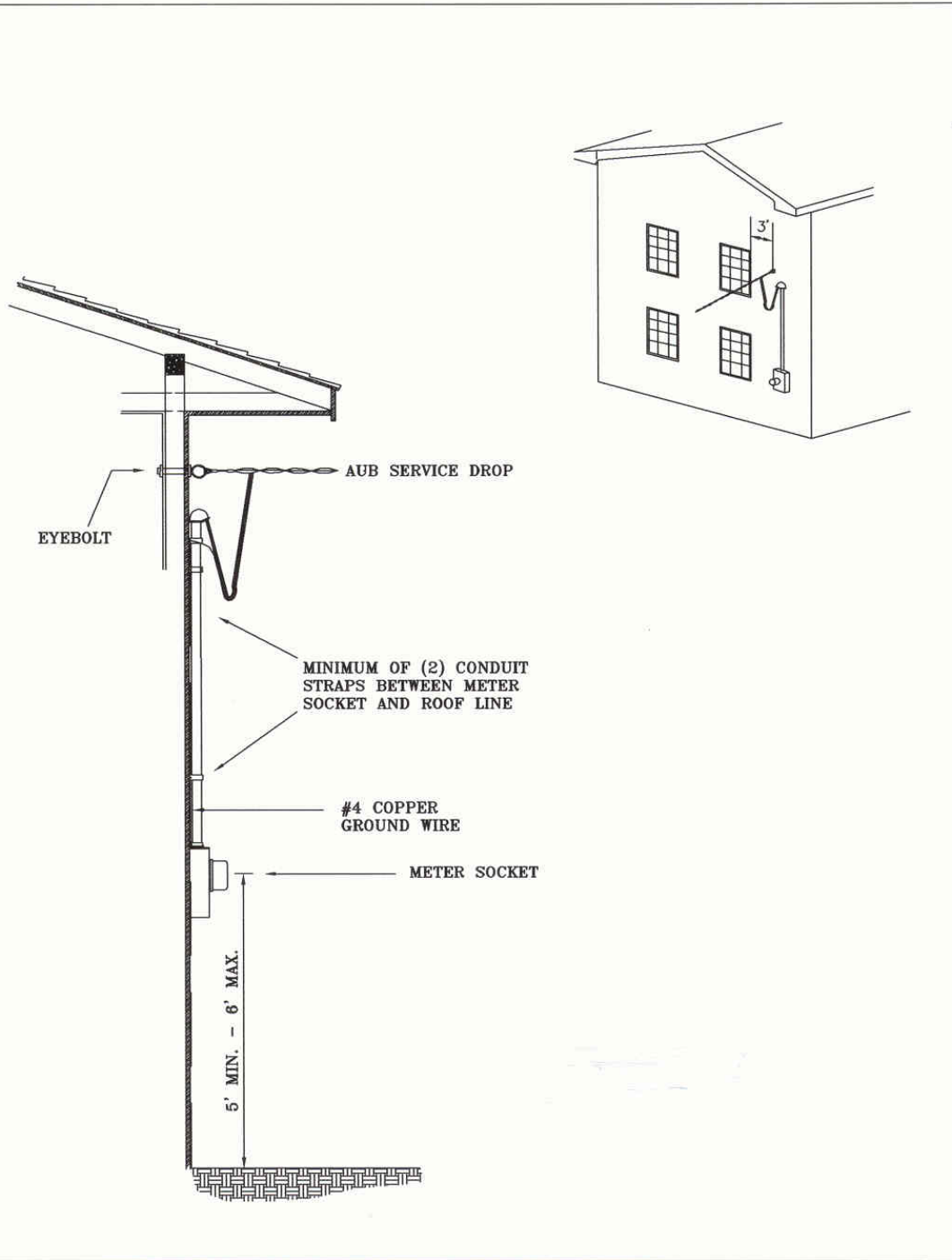

APPROVED:	<b>OVERHEAD SERVICE ATTACHED TO STRUCTURE</b>	ATHENS UTILITIES BOARD ATHENS, TENNESSEE
REVISED DATE:		DWG: OH-2

### TEMPORARY SERVICE POLE

1. The customer shall provide a suitable service pole with entrance conductor, meter center and protective devices properly installed for connection with AUB's service drop. Such pole shall have sufficient height and mechanical strength to support the overhead service drop.
2. The meter center shall be mounted securely to the wood pole such that the meter will not be tilted in any direction, located such that it will not be subjected to accidental damage, and shall have minimum clearances from obstructions of 12 inches on either side, above and below the receptacle and 36 inches in front.
3. A temporary pole shall not be fabricated by joining two or more pieces and shall be solid both in cross section and full length.
4. Service entrance conductors shall be encased in conduit, either Schedule 40 PVC or metallic. Metallic conduit shall be bonded to the ground wire with approved clamps. All metallic conduit ends shall be free of any burrs, sharp or rough surfaces and shall be equipped with bushings to protect the conductors.
5. The service entrance conductor leads shall extend a minimum of 36 inches from the weatherhead.
6. The ground conductor shall meet NEC requirements, and shall be one continuous piece from the grounding electrode to the weatherhead and shall extend a minimum of 36 inches from the weatherhead. It shall be installed adjacent to the conduit, and outside the meter center. There shall also be a ground conductor installed from the grounding terminal inside the meter center to the continuous ground conductor bonded with an approved bonding clamp. (Aluminum, copper-clad aluminum, or steel conductor not acceptable by AUB.)
7. The temporary pole shall be braced with (2) 2" x 4" boards, such that the braces will support the pole against the pull of the AUB service.
8. Temporary service shall be limited to single phase, 120/240 volts or 120/208 volts depending upon availability of electric service at the location. Temporary service at other voltages or for three phase loads or for loads exceeding 25 KW shall be considered as special cases and each shall be dealt with on its merit.
9. The customer shall agree to reimburse Athens Utilities Board an amount equal to the total unrecoverable cost of providing temporary where temporary facilities are required in excess of the service drop.

10. The temporary service pole shall be maintained in safe and good serviceable condition. An electrical inspection will be required each time the service is connected. Having been accepted and connected at a previous job site does not constitute acceptability at the new job site.
11. Each installation shall meet all requirements of the National Electric Code (NEC), National Electric Safety Code (NESC), and any other applicable codes, regulations, or requirements of authorities having jurisdiction as would be required for permanent service.
12. Athens Utilities Board reserves the right to decline service to any installation where the location and/or method of installation have not been approved by an authorized employee of AUB. All costs incidental to adding, relocating, and/or re-routing AUB facilities shall be at the customer's expense.

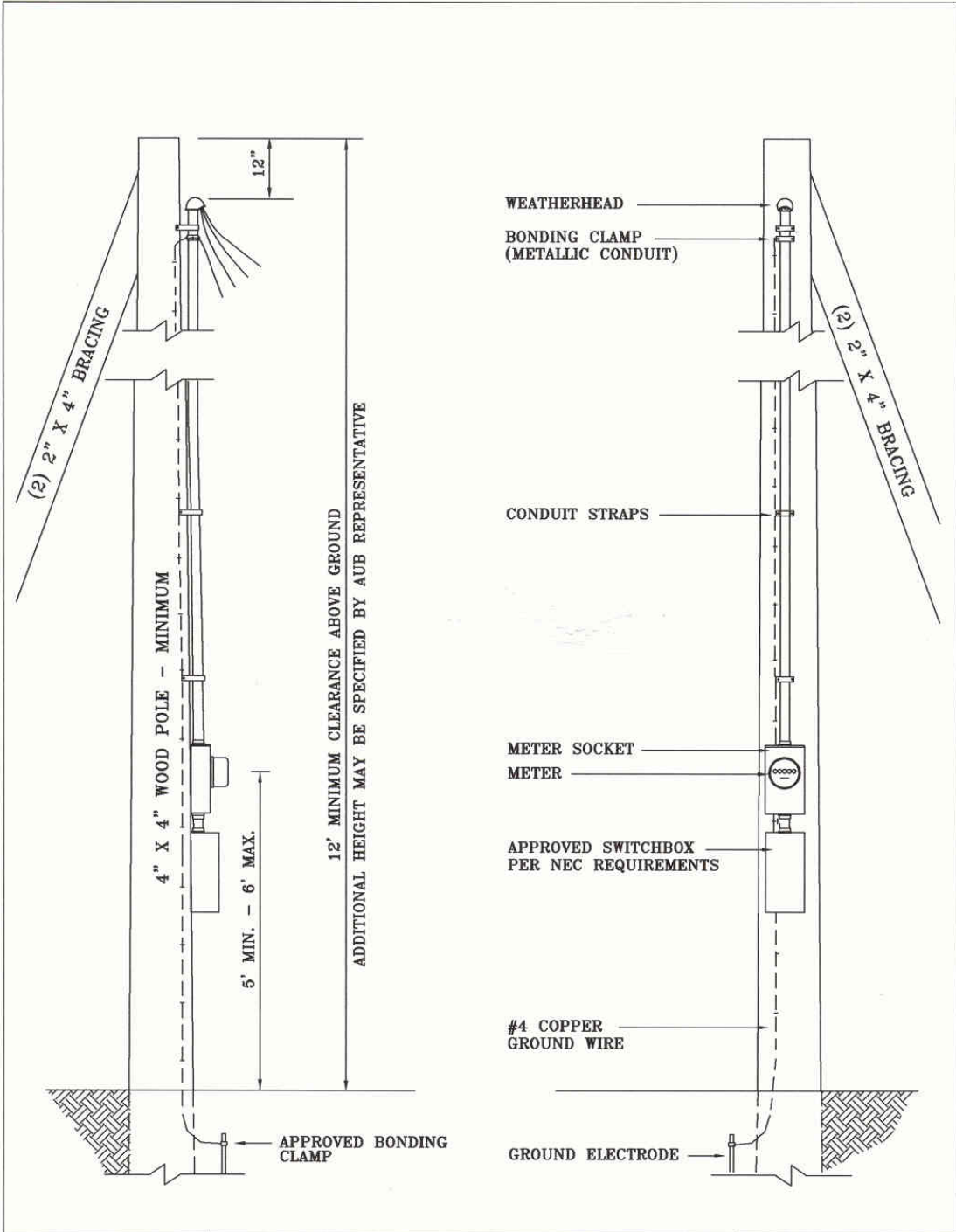

APPROVED:  
 REVISED DATE:

# TEMPORARY SERVICE POLE

ATHENS UTILITIES BOARD  
 ATHENS, TENNESSEE  
 DWG: OH-3

### MOBILE HOME SERVICE POLE

1. The customer shall provide a suitable service pole with entrance conductor, meter center and protective devices properly installed for connection with the Board's service drop. Such pole shall have sufficient height and mechanical strength to support the overhead service drop.
2. The meter center shall be mounted securely to the wood pole such that the meter will not be tilted in any direction, located such that it will not be subjected to accidental damage, and shall have minimum clearances from obstructions of 12 inches on either side, above and below the receptacle and 36 inches in front.
3. The center of the meter shall be no less than 5 feet, or more than 6 feet above finished grade.
4. A mobile home service pole shall not be fabricated by joining two or more pieces and shall be solid both in cross section and full length.
5. The point of attachment shall be a 5/8" machine bolt and eye-nut or 5/8" eyebolt furnished by the customer.
6. Service entrance conductors shall be encased in conduit, either Schedule 40 PVC or metallic. Metallic conduit shall be bonded to the ground wire with approved clamps.
7. The service entrance conductor leads shall extend a minimum of 36 inches from the weatherhead.
8. The grounding electrode shall be a driven rod, and at least 18 inches from the service pole where practical and shall not be set at an angle which would cause the rod to be driven under the building or structure into dry soil. The grounding conductor shall not be "jumped" from the building, or structure, to the electrode but shall go down adjacent to the foundation to not less than 6 inches underground and then over to the electrode. All connections shall be made with approved clamps.
9. The ground conductor shall meet NEC requirements, and shall be one continuous piece from the grounding electrode to the weatherhead and shall extend a minimum of 36 inches from the weatherhead. It shall be installed adjacent to the conduit, under the conduit straps, and outside the meter center. There shall also be a ground conductor installed from the grounding terminal inside the meter center to the continuous ground conductor bonded with an approved bonding clamp. (Aluminum, copper-clad aluminum, or steel conductor not acceptable by AUB.)
10. Each installation shall meet all requirements of the National Electric Code (NEC), National Electric Safety Code (NESC), and any other applicable codes, regulations, or requirements of authorities having jurisdiction as would be required for permanent service.

11. Athens Utilities Board reserves the right to decline service to any installation where the location and/or method of installation have not been approved by an authorized employee of AUB. All costs incidental to adding, relocating, and/or re-routing AUB facilities shall be at the customer's expense.

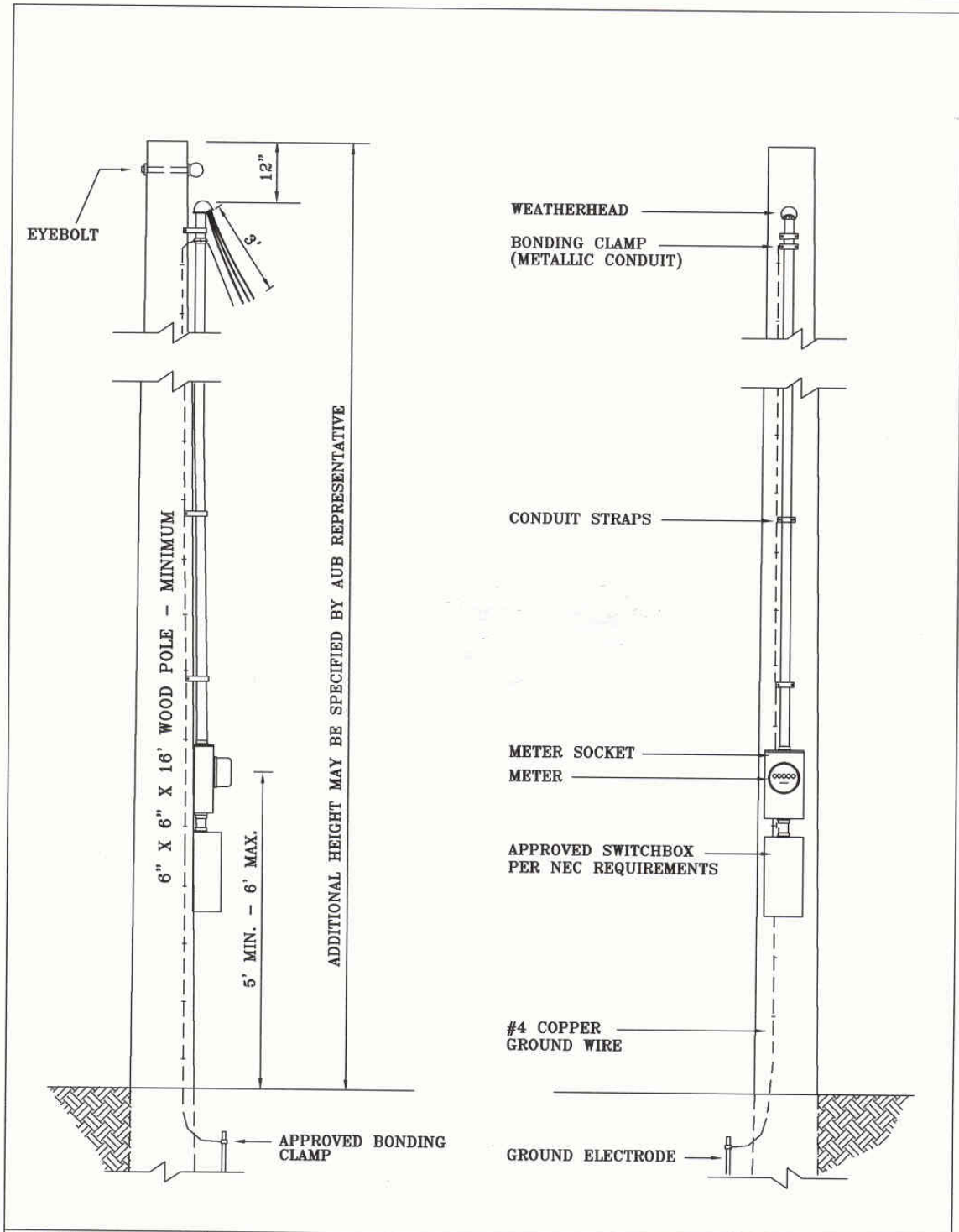

APPROVED:	<h2 style="margin: 0;">MOBILE HOME SERVICE POLE</h2>	ATHENS UTILITIES BOARD ATHENS, TENNESSEE
REVISED DATE:		DWG: OH-4

### RESIDENTIAL UNDERGROUND SERVICE

1. All meter center locations shall be determined by the AUB Engineering Department.
2. The meter center shall be mounted securely to a vertical surface such that the meter will not be tilted in any direction, located such that it will not be subjected to accidental damage, and shall have minimum clearances from obstructions of 12 inches on either side, above and below the receptacle and 36 inches in front.
3. The center of the meter shall be no less than 5 feet, or more than 6 feet above finished grade. Grading and/or fill must be completed before the meter will be installed.
4. The meter center shall be utilized as a meter receptacle only, and shall not be utilized for any other purpose – junction box, etc.
5. The ground conductor shall meet NEC requirements, and shall be one continuous piece from the grounding terminal inside the meter center to the grounding electrode.
6. The grounding electrode shall be a driven rod, and at least 18 inches from the building or structure where practical and shall not be set at an angle which would cause the rod to be driven under the building or structure into dry soil. The grounding conductor shall not be “jumped” from the building, or structure, to the electrode but shall go down adjacent to the foundation to not less than 6 inches underground and then over to the electrode. All connections shall be made with approved clamps.
7. The customer is required to install 3” PVC conduit from the meter center to a point designated by the AUB Engineering Department. This 3” PVC conduit shall be buried at a depth of 30 inches minimum with a continuous length of ¼” pull rope inside.
8. All excavation must be completed to final grade in the area in which the 3” PVC conduit is installed.
9. All underground conduit installations shall be inspected prior to back-filling ditch, for proper depth and material used. This will only be done during normal business hours by AUB personnel.
10. AUB will assume ownership of the conduit after the service has been energized. This does not include the ditch in which it lies.
11. Each installation shall meet all requirements of the National Electric Code (NEC), National Electric Safety Code (NESC), and any other applicable codes, regulations, or requirements of authorities having jurisdiction as would be required for permanent service.
12. Athens Utilities Board reserves the right to decline service to any installation where the location and/or method of installation have not been approved by an authorized employee



of AUB. All costs incidental to adding, relocating, and/or re-routing AUB facilities shall be at the customer's expense.

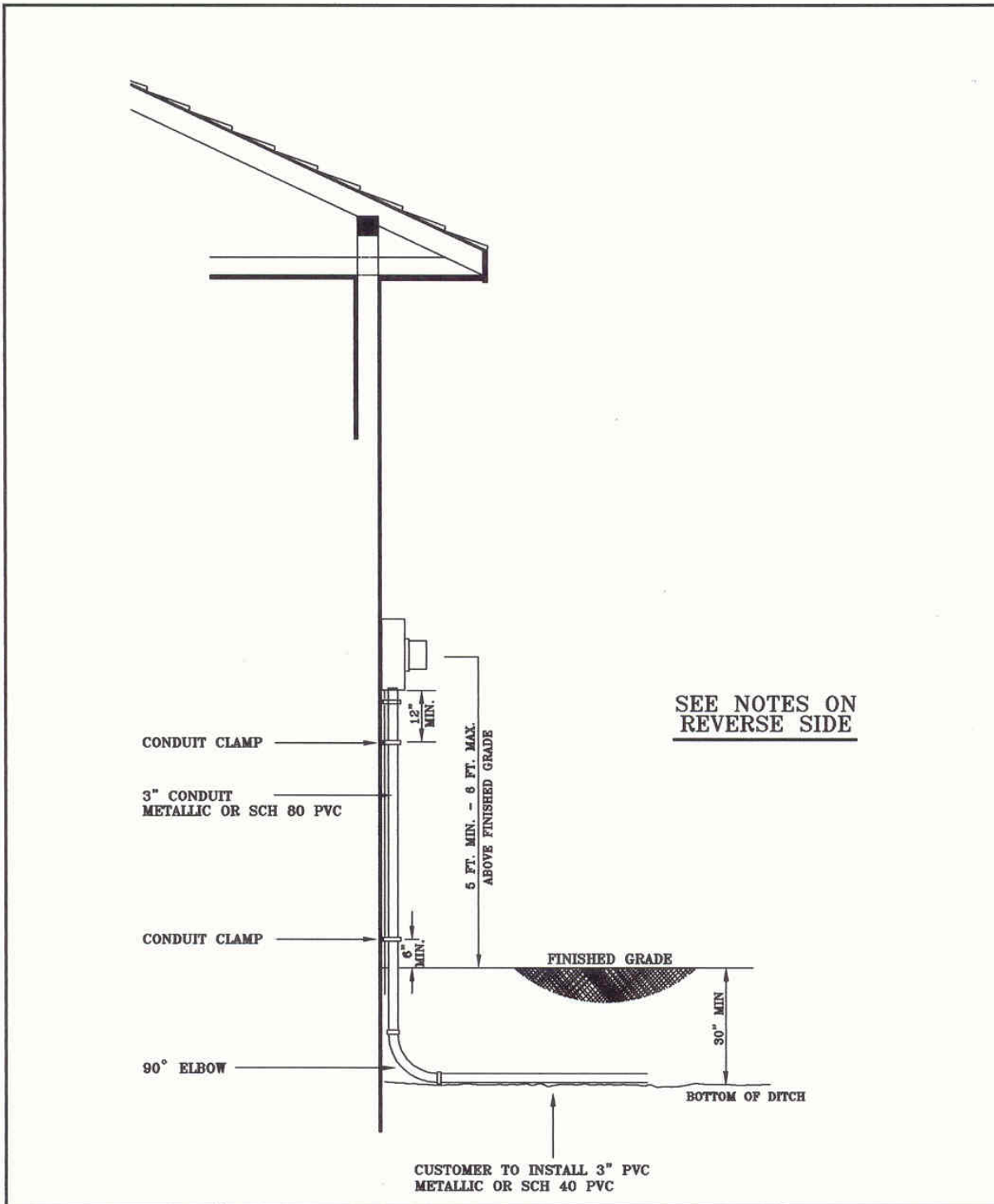

APPROVED	<b>RESIDENTIAL UNDERGROUND SERVICE</b>	ATHENS UTILITIES BOARD ATHENS, TENNESSEE
DATE		DWG. UG-1

### MOBILE HOME UNDERGROUND SERVICE POLE

1. The customer shall provide a 6"X6"X10' service pole with entrance conduit, conductor, meter center and protective devices properly installed.
2. The meter center shall be mounted securely to the wood pole such that the meter will not be tilted in any direction, located such that it will not be subjected to accidental damage, and shall have minimum clearances from obstructions of 12 inches on either side, above and below the receptacle and 36 inches in front.
3. The center of the meter shall be no less than 5 feet, or more than 6 feet above finished grade.
4. The meter center shall be utilized as a meter receptacle only, and shall not be utilized for any other purpose – junction box, etc.
5. The customer is required to dig a ditch and install 3" PVC conduit from the meter center to a point designated by the AUB Engineering Department. This 3" PVC conduit shall be buried at a depth of 30 inches minimum with a continuous length of ¼" pull rope inside.
6. All excavation must be completed to final grade in the area in which the 3" PVC conduit is installed.
7. All underground conduit installations shall be inspected prior to back-filling ditch, for proper depth and material used. This will only be done during normal business hours by AUB personnel.
8. AUB will assume ownership of the conduit after the service has been energized. This does not include the ditch in which it lies.
9. The grounding electrode shall be a driven rod, and at least 18 inches from the service pole where practical and shall not be set at an angle which would cause the rod to be driven under the building or structure into dry soil. The grounding conductor shall not be "jumped" from the building, or structure, to the electrode but shall go down adjacent to the foundation to not less than 6 inches underground and then over to the electrode. All connections shall be made with approved clamps.
10. The ground conductor shall be meet NEC requirements, and shall be one continuous piece from the grounding electrode to the meter center. It shall be installed adjacent to the conduit, under the conduit straps, to the grounding terminal inside the meter center. (Aluminum, copper-clad aluminum, or steel conductor not acceptable by AUB.)
11. Each installation shall meet all requirements of the National Electric Code (NEC), National Electric Safety Code (NESC), and any other applicable codes, regulations, or requirements of authorities having jurisdiction as would be required for permanent service.
12. Athens Utilities Board reserves the right to decline service to any installation where the location and/or method of installation have not been approved by an authorized employee of AUB. All

costs incidental to adding, relocating, and/or re-routing AUB facilities shall be at the customer's expense.

**RESIDENTIAL UNDERGROUND PRIMARY**

1. The primary conduit system will be designed and staked by the AUB Engineering Department.
2. The customer shall install the conduit system as specified by AUB.
3. The customer is required to dig a ditch and install 3" or 4" PVC conduit. This conduit shall be buried at a minimum depth of 36 inches with a continuous length of ¼" pull rope inside.
4. The minimum depth must be maintained after the area in which the conduit is installed has been cut or filled to final grade.
5. Conduits terminating at a pole must be schedule 80 PVC and extend 30" to 36" above final grade. Conduits terminating at junction boxes and pad mount transformers must extend 6" to 8" above final grade.
6. All underground conduit installations shall be inspected prior to back-filling ditch, for proper depth and material used. This will only be done during normal business hours by AUB personnel.
7. AUB will assume ownership of the conduit after the service has been energized. This does not include the ditch in which it lies.
8. Each installation shall meet all requirements of the National Electric Code (NEC), National Electric Safety Code (NESC), and any other applicable codes, regulations, or requirements of authorities having jurisdiction as would be required for permanent service.
9. Athens Utilities Board reserves the right to decline service to any installation where the location and/or method of installation have not been approved by an authorized employee of AUB. All costs incidental to adding, relocating, and/or re-routing AUB facilities shall be at the customer's expense.

## SCHEDULE OF RULES AND REGULATIONS

1. **Application of Service:** Each prospective Customer desiring electric service may be required to sign Distributor's standard form of application for service or contract before service is supplied by the Distributor.
2. **Deposit:** A deposit or suitable guarantee approximately equal to twice the average monthly bill may be required of any Customer before electric service is supplied. Distributor may at its option return deposit to Customer after one year. Upon termination of service, deposit may be applied by Distributor against unpaid bill of Customer, and if any balance remains after such application is made, said balance shall be refunded to Customer. **Additional information regarding Deposits can be found in AUB 05-07 SPP entitled Customer Deposits.**
3. **Point of Delivery:** The point of delivery is the point, as designated by Distributor, on Customer's premises where current is to be delivered to building or premises. All wiring and equipment beyond this point of delivery shall be provided and maintained by Customer at no expense to Distributor.
4. **Customer's Wiring Standards:** All wiring of Customer must conform to Distributor's requirements and accepted modern standards, as exemplified by the requirements of the National Electrical Safety Code and the National Electrical Code.
5. **Inspections:** Distributor shall have the right, but shall not be obligated, to inspect any installation before electricity is introduced or at any later time, and reserves the right to reject any wiring or appliances not in accordance with Distributor's standards; but such inspection or failure to inspect or reject shall not render Distributor liable or responsible for any loss or damage resulting from defects in the installation, wiring, or appliances, or from violation of Distributor's rules, or from accidents which may occur upon Customer's premises.
6. **Underground Service Line:** Customers desiring underground service lines from Distributor's overhead system must bear the excess cost incident thereto. Specifications and terms for such construction will be furnished by Distributor on request.
7. **Customer's Responsibility for Distributor's Property:** All meters, service connections, and other equipment furnished by Distributor shall be, and remain, the property of Distributor. Customer shall provide a space for and exercise proper care to protect the property of Distributor on its premises, and in the event of loss or damage to Distributor's property arising from neglect of Customer to care for same, the cost of the necessary repairs or replacements shall be paid by Customer.

8. **Right of Access:** Distributor's identified employee shall have access to Customer's premises at all reasonable times for the purpose of reading meters, testing, repairing, removing, or exchanging any or all equipment belonging to Distributor.
9. **Billing:** Bills will be rendered monthly and shall be paid at the office of Distributor, by telephone, online at [www.aub.org](http://www.aub.org), or at other locations designated by Distributor. Failure to receive bill will not release Customer from payment obligation. Should bills not be paid by due date specified on bill, Distributor may disconnect service pursuant to AUB policy AUB-05-06, Pay Agreements and Collections. Should the due date of the bill fall on a weekend or holiday, payment may be made without penalty on the following business day. Remittances received by mail after the due date will not be subject to such additional charges if the incoming envelope bears United States Postal Service date stamp of the due date or any date prior thereto. **Additional related formation can be found in AUB 01 SPP entitled Customer Service Policy.**
10. **Discontinuance of Service by Distributor:** Distributor may refuse to connect or may discontinue service for the violation of any of its Rules and Regulations, or for violation of any of the provisions of the Schedule of Rates and Charges, or of the application of Customer or contract with Customer. **Disconnection of services due to nonpayment on the account is explained in AUB policy AUB-05-06.** Distributor may discontinue service of Customer for the theft of current or the appearance of current theft devices on the premises of Customer. The discontinuance of service by Distributor for any causes as stated in this rule does not release Customer from his obligation to Distributor for the payment of minimum bills as specified in application of Customer or contract with Customer. **Additional information can be found in AUB 04 SPP entitled Suspension for Nonpayment Disconnects in Times of Extreme Outdoor Temperatures.**
11. **Connection, Reconnection, and Disconnection Charges:** Distributor may establish and collect standard charges to cover the reasonable average costs, including administration, of connecting or reconnecting service, or disconnecting connections and reconnections are performed after normal office hours, or when special circumstances warrant.
12. **Termination of Contract by Customer:** Customer who have fulfilled their contract terms and wish to discontinue service must give at least three (3) days written notice to that effect, unless contract specifies otherwise. Notice to discontinue service prior to expiration of contract term will not relieve Customer from any minimum or guaranteed payment under any contract or rate.
13. **Service Charges for Temporary Service:** Customer requiring electric service on a temporary basis may be required by Distributor to pay all costs for connection and disconnection incidental to the supplying and removing of service. This rule applies to circuses, carnivals, fairs, temporary construction, and the like.

- 14. Interruption of Service:** Distributor will use reasonable diligence in supplying current, but shall not be liable for breach of contract in the event of, or for loss, injury, or damage to persons or property resulting from, interruptions in service, excessive or inadequate voltage, single-phasing, or otherwise unsatisfactory service, whether or not caused by negligence.
- 15. Shortage of Electricity:** In the event of an emergency or other condition causing a shortage in the amount of electricity for Distributor to meet the demand on its system, Distributor may, by an allocation method deemed equitable by Distributor, fix the amount of electricity to be made available for use by Customer and/or may otherwise restrict the time during which Customer may make use of electricity and the used which Customer may make of electricity. If such actions become necessary, Customer may request a variance because of unusual circumstances including matters adversely affecting the public health, safety and welfare. If Customer fails to comply with such allocation or restriction, Distributor may take such remedial actions as it deems appropriate under the circumstances including temporarily disconnecting electric service and charging additional amounts because of the excess use of electricity. The provisions of the Section entitled Interruption of Service if this Schedule of Rules and Regulations are applicable to any such allocation or restriction.
- 16. Voltage Fluctuations Caused by Customer:** Electric service must not be used in such a manner as to cause unusual fluctuations or disturbances to Distributor's system. Distributor may require Customer, at his own expense, to install suitable apparatus which will reasonably limit such fluctuations.
- 17. Additional Load:** The service connection, transformers, meters, and equipment supplied by Distributor for each Customer have definite capacity, and no addition to the equipment or load connected thereto will be allowed except by consent of Distributor. Failure to give notice of additions or changes in load, and to obtain Distributor's consent for same, shall render Customer liable for any damage to any of Distributor's lines or equipment caused by additional or changed installation.
- 18. Standby and Resale Service:** All purchased electric service (other than emergency or standby service) used on the premises of Customer shall be supplied exclusively by Distributor, and Customer shall not, directly or indirectly, sell, sublet, assign, or otherwise dispose of the electric service or any part thereof.
- 19. Notice of Trouble:** Customer shall notify Distributor immediately should the service be unsatisfactory for any reason, or should there be any defects, trouble, or accidents affecting the supply of electricity. Such notices, if verbal, should be confirmed in writing.
- 20. Non-Standard Service:** Customer shall pay the cost of any special installation necessary to meet his peculiar requirements for services at other at other standard



voltages, or for the supply of closer voltage regulation than required by standard practice.

- 21. Meter Tests:** Distributor will, at its own expense, make periodical tests and inspections of its meters in order to maintain a high standard of accuracy. Distributor will make additional tests or inspections of its meters at the request of Customer. If tests made at Customer's request show that the meter is accurate within two percent (2%), slow or fast, no adjustment will be made in Customer's bill, and Distributor's standard testing charges will be paid by Customer. In case the test shows meter to be in excess of two percent (2%), fast or slow, an adjustment shall be made in Customer's bill over a period of not over thirty (30) days prior to date of such test, and cost of making test shall be borne by Distributor.
- 22. Relocation of Outdoor Lighting Facilities:** Distributor shall, at the request of Customer, relocate or change existing Distributor-owned equipment. Customer shall reimburse Distributor for such changes at actual cost including appropriate overheads.
- 23. Billing Adjusted to Standard Periods:** The demand charges and the blocks in the energy charges set forth in the rate schedules are based on billing periods of approximately one month. In the case of the first billing of new accounts (temporary service, cotton gins, and other seasonal customer excepted) and final billing of all accounts (temporary service excepted) where the period covered by the billing involves fractions of a month, the demand charges and the blocks of the energy charge will be adjusted to a basis proportionate with the period of time during which service is extended.
- 24. Home Energy Conservation Surveys:** All customers of Distributor receiving service under the residential rate schedule are eligible for a free energy conservation survey of their home. As part of such survey information covering efficient utilization of electric energy will be made available, including a wide variety of specific recommendations as to the materials and equipment that would provide effective weatherization and thereby yield the greatest energy saving for the customer. Customers will also be furnished a list of private contractors in their area which install various types of energy-saving materials and equipment, and instructional material concerning the self-installation of such materials and equipment.
- 25. Scope:** This Schedule of Rules and Regulations is a part of all contracts for receiving electric service from Distributor, and applies to all service received from Distributor, whether the service is based upon contract, agreement, signed application, or otherwise. A copy of this schedule, together with a copy of Distributor's Schedule of Rates and Charges, shall be kept open to inspection at the offices of Distributor. **Additional information can be found in AUB 01-01 SPP entitled Information to Consumers.**

**26. Revision:** These Rules and Regulations may be revised, amended, supplemented, or otherwise changed from time to time, without notice. Such changes, when effective, shall have the same force as the present Rules and Regulations.

**27. Conflict:** In case of conflict between any provision of any rate schedule and the Schedule of Rules and Regulations, the rate schedule shall apply.

*Division of Gas – Policies and Procedures Manual*  
*Standard Policies and Procedures*  
*Table of Contents*

AUB-03-01	Obtaining Gas Service	137
AUB-03-02	Meter and Line Extension Policy	140
AUB-03-03	Gas Rate Schedule	146
AUB-03-04	Gas Tap Policy and Fee	148
AUB-03-05	Appliance Installation	152
AUB-03-06	Excess Flow Valve Installation and Maintenance	155
AUB-03-07	Gas Central Heat Loan Policy	157
AUB-03-08	Gas Water Heater Lease Policy and Fees	159
<b>ADDENDUMS:</b>		
03-01-01	Standard Application for Service	163
03-01-02	Application for Gas Service Line	165
03-01-03	Natural Gas Service Information	167
03-01-04	Federal Safety Regulation – Excess Flow Valve Required	173
03-02-01	Pressure Testing Procedures	175

Athens Utilities Board

<b>Division of Gas – Policies and Procedures Manual</b>	
<b>Standard Policies and Procedures</b>	
<b>Policy Number – AUB-03-01</b>	<b>Revision Number: 4</b>
<b>Subject</b> <b>Obtaining Gas Service</b>	<b>Effective Date: 10-01-2009</b>
	<b>Superintendent Approval:</b>
	<b>General Manager Approval:</b>

**1.0 PURPOSE**

The purpose of this policy is to outline the requirements associated with obtaining gas service from Athens Utilities Board (AUB).

**2.0 SCOPE**

This policy applies to all residential and industrial customers who are physically connected to or have the potential to be physically connected to the AUB Natural Gas Distribution System.

**3.0 REFERENCES**

- (1) Athens Utilities Board Division of Gas, Rules and Regulations and Extension Policies

**4.0 GENERAL**

A formal application for original or additional service must be made at the offices of AUB or with a duly appointed agent of AUB and must be approved before service connection. A meter will not be set or service connected before payment of the service line installation charge and any additional applicable charges are made.

Any exceptions to this policy will be made at the sole discretion of AUB’s local control authority.

**5.0 DEFINITIONS**

**AUB** – means the Athens Utilities Board, and its duly authorized employees, agents, and representatives

**Board** – means the Chairman and all Commissioners but does not include any employees

**BTUH** – The measurement of heat value of natural gas as defined by the British Thermal Unit per Hour

**Customer** – Any person, business, or other entity that receives natural gas service from Athens Utilities Board, Division of Natural Gas

**Division** – The Athens Utilities Board, Division of Gas

**Installer** – A bonded gas fitter as on file with AUB

**Local Control Authority** – Superintendent of Gas or duly authorized representative

**Service Connection** – Shall mean the tap of the main and that portion of the line extending from the tap of the main to and including the meter and meter installation.

## **6.0 PROCEDURES/POLICY**

### **6.1 Application and Contract for Service**

Each original customer desiring gas service will be required to sign AUB's standard application (*Addendum 03-01-01*) and the Division's standard (*Addendum 03-01-02*) application before service is supplied. The use of gas service by a customer shall bind the customer by the terms of the applicable standard contract form, even though the contract form may not be actually signed by the original customer.

The AUB standard application shall be provided to each prospective customer.

As a condition of providing service, the Board shall have the right to require an applicant to sign a minimum bill contract in an amount and for a period of time as is reasonably necessary to support the Division's investment.

If the customer, after signing application for gas service, does not take the service, the customer shall reimburse AUB for its expenses incurred to furnish gas service.

AUB's receipt of a customer's application for service shall not obligate AUB to render the service. If the Division determines the service applied for cannot be supplied, its liability shall be limited to the return of any monies paid by the applicant.

Whenever an application is made for service to a premises about which AUB knows there is a dispute regarding ownership or the right of occupancy, and one or more of the claimants attempts to prevent such service being furnished, AUB reserves the right to adopt one of the following courses:

1. To treat the applicant in actual possession of the premises to be served as being entitled to such service, irrespective of the rights or claims of other persons.
2. To withhold service, pending a judicial or other settlement of the rights of the various claimants.

Each applicant will receive a copy of the Division's "Natural Gas Service Information" (*Addendum 03-01-03*) and "Excess Flow Valve Information" (*Addendum 03-01-04*).

### **6.2 Fees**

AUB will collect fees and deposits as delineated by the Board. The Board may, at its discretion, invest AUB with the authority to enter into contract with the customer for payment of fees the Board determines necessary. Promotional fee reduction or fee elimination may be offered from time to time.

### **6.3 Character of Service**

**Standard service** is normally provided at approximately 1,000 BTU per cubic foot heat content and approximately 0.6 specific gravity as referred to air. The Division reserves the right to furnish a substitute or supplemental gas of different heat content and/or specific gravity in the event of emergency or for other reasons.

Normal service is provided at a nominal pressure of seven inches water column (four ounces psig) above atmosphere. Pressure specified is nominal pressure and the Division does not guarantee actual pressure.

Customers requiring service at other than standard pressure shall confer with the Division regarding the type of service required. Before the customer proceeds with the purchase of equipment or piping in such cases, he/she should contact the Division, which will furnish information on the ability of the Division to meet special requirements. The customer shall pay the cost of any special installation made to meet peculiar requirements. Nothing contained herein shall obligate AUB to provide such special service.

AUB shall not be liable for personal injuries or for any damages to a customer's equipment or property caused by high or low pressure or by fluctuations in pressure in the Division's natural gas system.

The Division will endeavor to furnish continuous gas service and to maintain reasonable constant pressure, but AUB cannot and does not guarantee to the customer any fixed pressure of continuous service. The Division shall not be liable for any damages, interruption or disturbance of service.

Operational maintenance and/or repair constraints may result in the gas supply being shut off without notice. However, every reasonable effort will be made by AUB to notify customers of such outages. AUB shall not be held liable for any damages from such interruption of service or for damages from the resumption of service without notice. Every reasonable effort will be made to provide continuous gas service to the customers of the Board's Division of Gas.

In times of emergencies or in times of gas shortage, AUB reserves the right to restrict all customers both in the amount of gas used and the purpose for which it is used.

### **6.4 Billing**

Service availability charges will commence upon the Division's completion of the customer's service line regardless of when the customer commences utilizing the service. The service availability charge will be levied monthly regardless of the customer's monthly use.

The volume of gas delivered to a customer using non-standard service, as metered or estimated, shall be corrected in accordance with Boyle's law to its equivalent volume at a gauge pressure of four (4) ounces per square inch.

Athens Utilities Board

<b>Division of Gas – Policies and Procedures Manual Standard Policies and Procedures</b>	
<b>Policy Number – AUB-03-02</b>	<b>Revision Number: 4</b>
<b>Subject Meter and Line Extension Policy</b>	<b>Effective Date: 07-01-2013</b>
	<b>Superintendent Approval:</b>
	<b>General Manager Approval:</b>

**1.0 PURPOSE**

The purpose of this policy is to standardize Athens Utilities Board’s (AUB) approach to review and approval of all development design within the AUB service areas, and to standardize the policy regarding cost sharing and agreements for natural gas service.

**2.0 SCOPE**

This policy applies to all development within the Athens Planning Region of Athens, Tennessee.

**3.0 REFERENCES**

- (1) Athens Utilities Board Division of Gas, Rules and Regulations and Extension Policies
- (2) Tennessee Regulatory Authority, The United States Department of Transportation, Natural Gas Operational Guidelines
- (3) International Fuel Gas Code
- (4) Athens Utilities Board, AUB-03, Schedule of Rates and Fees

**4.0 GENERAL**

Final review and approval of the natural gas supply system will be by the local control authority representing AUB as dictated by References 3-1 and 3-2.

Any exceptions to this policy will be made at the sole discretion of AUB’s local control authority.

All gas line construction plans for subdivisions shall include service from the main gas line to the property line of each proposed lot in order that each proposed lot, *at the time of construction*, may be served by gas without the installation of additional lines. The end of each service shall be properly marked.

**5.0 DEFINITIONS**

**AUB** – means the Athens Utilities Board, and its duly authorized employees, agents, and representatives

**Board** – means the Chairman and all Commissioners but does not include any employees

**BTUH** – The measurement of heat value of natural gas as defined by the British Thermal Unit per Hour

**Customer** – Any person, business, or other entity that receives natural gas service from Athens Utilities Board, Division of Natural Gas

**Division** – The Athens Utilities Board, Division of Gas

**Installer** – A bonded gas fitter

**Local Control Authority** – Superintendent of Gas or duly authorized representative  
**Service Connection** – Shall mean the tap of the main and that portion of the line extending from the tap of the main to and including the meter and meter installation.

## **6.0 POLICY/PROCEDURES**

### **6.1 Meters**

No one shall do anything that will in any way interfere with or prevent the proper registration of a meter. No one shall tamper with or perform work on a gas meter without the written permission of the Division. No one shall install any pipe or other device that will cause gas to pass through or around a meter without the passage of such gas being fully registered by the meter.

The meter will be located at the utility's discretion. The location will be such that the meter and connections are accessible so the meter and all of its accompanying components may be read, maintained and/or changed. The customer may not encumber the meter set in any way that will inhibit AUB's ability to read and maintain the meter set. In no event shall any portion of the meter and regulator assembly be installed inside or under any portion of a building. There shall be no walls, covers, decks, porches, or other structures erected over or around the gas meter. There will be no type of construction that restricts free access to the meter. Meters located in positions not in conformity with the foregoing requirements will be moved at the expense of the customer. The Division reserves the right to move a meter, at its own expense, to a more accessible location despite the fact that it may have previously approved the current location.

Meters and equipment supplied by AUB for each customer have definite capacities. Additions to the customer's connected load shall be made only with the notification of the Division. Failure to give notice of additions or changes in load or to obtain the Division's consent for it shall render the customer liable for any damage to AUB's equipment. Additionally, the customer shall be liable for any natural gas usage the Division estimates that the meter was not able to register.

AUB will, at its own expense, make periodic tests and inspections of its meters in order to maintain a high standard of accuracy. The Board will make additional tests or inspections of its meters at the request of the customer at a fee consistent with the applicable AUB Fee Schedule. If such tests show that the meter is accurate within two percent (2%) no adjustments will be made in the customer's bill.

In case the test shows the meter to be in excess of two percent (2%) an adjustment will be made in the customer's bill for an appropriate and equitable period not exceeding 90 days prior to the date of such tests, and the cost of making such tests shall be borne by AUB.

Where two or more meters are to be installed at one premise, such as an office building or apartment building, they shall be grouped in one common place accessible at all times. The expense of installing such meter centers, including the meter manifold, shall be borne by the Division.

Except with written consent of AUB, service will not be furnished through a single meter to more than one customer. Where two or more customers occupy one location and receive service through the same meter, the customer who made application for service shall be liable for all natural gas consumed.



## **6.2 Service Lines**

The Division will install the service line from the gas distribution main to the meter location. The customer shall reimburse AUB based on the Board's established rates for the portion of the service line that is located within the property of the customer.

It is the responsibility of the customer to inform the Division of the presence and location of any and all known buried utilities located on the customer's property. The Division will not be held liable for damages incurred to utilities that are not correctly located. In no event will a service line be installed or placed under any portion of a building, residence, or other structure. In the event that a building is constructed, enlarged, moved or relocated, or otherwise made to cover any portion of the service line, the service line will be relocated at the expense of the customer. Customers who wish to have their service line or meter set moved or modified due to remodeling or some other customer convenience will be charged fees pursuant to those listed in the applicable AUB Fee Schedule. The customer in no case will be permitted to move or modify the service line or meter set. The Division avoids installing a service line under paved or concrete driveways, parking areas, loading docks, etc. The Division will choose the easiest route for service line installation.

The service line from the main to the customer's gas meter location shall remain the property of the AUB and will be maintained by the Division. All piping and equipment up to, and including meter outlet connection shall be property of, and maintained by, the Division. The lines and meter set are the wholly owned property of AUB. The customer may in no way encumber AUB's access to the lines or meter set.

The customer shall provide a space for and exercise proper care to protect the property of AUB on his/her premises. In the event of loss or damage to AUB's property arising from neglect of the customer, the customer shall pay the cost of necessary repairs or replacements.

## **6.3 Access to Customer's Premises**

AUB's representatives and employees shall be granted access to customer's premises at all times for the purpose of reading meters, testing, inspecting, repairing, disconnecting, and replacing all equipment belonging to AUB, and for inspecting piping, appliances, equipment and premises in order to determine that the Division's policy(s) and safety requirements are being met.

## **6.4 Point of Delivery**

The point of delivery shall be at the downstream gas meter connection. All piping, appliances and equipment beyond the outlet meter connection shall be the property of (and be maintained by) the customer. All piping and equipment up to and including all meter outlet connection shall be property of and maintained by AUB. AUB shall not be liable for injury to person or property because of any defect or negligence in the installations, maintenance or use of any piping or equipment.

## **6.5 Multiple Delivery Points**

The rates fixed in the AUB Schedule of Rates and Fees for each class of service are based on the supply of service to the customer through a single meter. Customers requiring separate supply points will be separately metered and billed.

## **6.6 Main Line Extensions**

Natural gas service to any customer requiring a main line extension, addition, or improvement will be furnished only if AUB determines it will give a fair and adequate rate of return on the Division's investment.

AUB may require a written contract satisfactory to the Board that ensures that the gross annual revenue derived from a main line extension or modification will provide a fair and adequate rate of return on the Division's investment. The authority to make extensions and modifications are permissive only, not mandatory.

AUB reserves the right to determine if it is in the best interest of the Division to install main lines and/or modifications regardless of customer demand.

Any main line extension or modification remains the property of AUB regardless of a customer's contract with AUB. AUB may at its discretion serve additional customer(s) from any and all main lines.

## **6.7 Interruptible Customers**

Customers who request natural gas service at the interruptible rate must maintain adequate stand-by facilities.

AUB reserves the right to determine if a customer who requests interruptible service has sufficient usage to be advantageous to the Division classifying them interruptible.

The Division reserves the right to limit or restrict the use of interruptible service to any customer at any time deemed necessary on immediate verbal or written notice. The Division will give notification when the customer may return to its normal use of natural gas.

All natural gas usage during periods of interruption after verbal or written notice has been given will result in the customer being billed AUB's highest natural gas rate penalties pursuant to the AUB Rate and Fee Schedule until the restriction or limitation of natural gas usage has been lifted and the customer notified.

## **6.8 Controlling Authority**

The Division will operate under the guidelines of the United States Department of Transportation as it is translated and administered by the Tennessee Regulatory Authority.

## **6.9 Regulatory Authority**

The Division shall utilize the standards as developed by the Tennessee Regulatory Authority, The United States Department of Transportation, and the International Fuel Gas Code. Additional regulations are promulgated by the Division based on its experience and concern for the safety of its customers. In case of irreconcilable conflicts between the requirements of the regulations specified, the Athens Utilities Board – Division of Gas shall control.

## **6.10 Bonded Gas Fitter**

The definition of a Bonded Gas Fitter is any person or business whom the Athens Utilities Board, Division of Natural Gas approves to perform natural gas work and who maintains a liability bond pursuant to the requirements of the AUB Rates and Fees Schedule.

## **6.11 Customer's Piping**

All gas piping beyond the outlet side of the meter shall be installed and maintained at the expense of the customer. The customer owns and is responsible for the gas distribution system in the home or business. As part of the consideration for providing natural gas service, the Division is not responsible for any claims for damages from any cause incidental to the installation or operation of the customer's piping, equipment, and appliances or use of natural gas.

All customer's piping shall be installed in accordance with the International Fuel Gas Code. The installer shall be a Bonded Gas Fitter and be qualified to adequately size the customer's piping in accordance with applicable regulations. Piping shall be of such size and so installed as to provide a supply of gas sufficient to meet maximum demand without undue loss of pressure between the point of delivery and gas appliances/equipment.

All pipes shall be either a minimum Schedule 40 black iron or flexible stainless steel meeting ASTM A240 Type 304 with a polyethylene jacket. Fittings and valves shall be threaded or welded black iron for black iron pipe installations or those recommended by the stainless steel pipe manufacturer. All valves shall be UL, CSA or AGA approved. Only International Fuel Gas Code approved pipe shall be used. A shut off valve and a drip leg are required at the meter set and each appliance/equipment served. Each appliance shall have an accessible gas shutoff valve operable within the same room as the appliance. Drip legs shall be provided at all vertical drops adjacent to appliances/equipment and at such points to act as storage for condensate and shall be readily accessible for draining. The diameter of piping constituting the drip shall be the same as the line it serves.

Buried black iron must be welded and cathodically protected from corrosion. Plastic pipe (MDPE 2406-ASTM 2513) may be installed. The plastic pipe installer must have certification in natural gas plastic pipe heat fusing. Tracing wire must be buried with plastic lines. Minimum soil cover for all buried lines shall be 12 inches. No gas piping shall be placed underground closer than 12 inches from water, drainage, electrical or sewer lines. Laying or installing gas piping in the same ditch as water, sewer, electricity or drainage is prohibited. All buried piping will be left exposed for inspection prior to covering. AUB is not responsible for any maintenance of the customer's buried piping.

Piping through solid floors and foundations will be encased in a sleeve. If the entry is through an exterior wall, the sleeve will be constructed so as to eliminate the entry of water. The sleeve shall be sealed on the interior side of the wall only. When it is not practical to avoid the installation of building piping that is buried or laid under a floor slab, the gas piping shall be encased in PVC or HDPE plastic Schedule 40 pipe and joints, or the piping may be installed in a channel in the floor with a metal cover. The casing shall extend into a normally useable and accessible portion of the building. At the point where a slab casing terminates in the building, the space between the casing and gas piping shall be tightly and permanently sealed. The casing shall extend at least four (4) inches outside the building. The piping should be installed so that replacement will not cause damage to the building.

## **6.12 Testing Piping for Fitness**

Before a customer's gas piping system is placed into service, it shall be carefully tested by a Bonded Gas Fitter, to assure that it is gas tight. If repairs or additions are made following the pressure test, the affected piping shall again be tested. Where any part of the system is to be enclosed, the test should precede the work of closing in. The piping shall be tested with air or inert gas. The pressure test is the responsibility of the installer. The installer must present written proof to the customer and the Division that the test was performed successfully.

Customer's gas piping shall withstand a pressure of at least 20 psig for a minimum of 120 minutes without showing a drop in pressure. A 50-psi gauge is required for this test.

The Bonded Gas Fitter will be assessed a service charge for each inspection beyond the first inspection. The service charge will be in accordance with fees listed in the applicable AUB Rates and Fees Schedule.

The Bonded Gas Fitter assumes full responsibility for any and all operation, correction or damages caused by operation or testing of the customer's gas piping, before, during, and after any testing by the Division. As part of the consideration for this installation, the natural gas customer does hereby release AUB from any and all claims for damages from any causes incidental to the installation or operation of a customer's piping, appliances, equipment or use of natural gas.

The pressure test is for the good use of AUB only, and provides no guarantee of any kind.

The bonded gas fitter must complete the form available in the Pressure Testing Policy, *Addendum 03-02-01*.

## **6.13 Inspection**

An authorized representative of the Division must inspect all customer gas piping. AUB reserves the right to refuse service to any customer whose piping, equipment, or appliances do not meet minimum requirements. Failure to exercise this right does not render AUB responsible for any damage resulting from defects in the installation, piping, or appliances.

After the customer's piping, equipment and appliances have been installed, the customer's installing contractor must contact the Division to arrange an inspection. Upon completion of a successful inspection, the Division's lock will be removed from the meter set. ***Under no circumstances*** will a contractor or customer be allowed to operate, unlock, or tamper with a meter set. ***Under no circumstances*** will a customer or contractor use any gas in any way except through an inspected and accepted piping/appliance system. AUB reserves the right to refuse or discontinue service to any piping, equipment, or appliances not in accordance with cited regulatory authority, but any failure to exercise this right shall not render AUB liable or responsible for any loss or damage resulting from defects in the installation, piping, or appliances.

Athens Utilities Board

<b>Division of Gas – Policies and Procedures Manual Standard Policies and Procedures</b>	
<b>Policy Number – AUB-03-03</b>	<b>Revision Number: 4</b>
<b>Subject Gas Rate Schedule</b>	<b>Effective Date: 10-01-2009</b>
	<b>Superintendent Approval:</b>
	<b>General Manager Approval:</b>

**1.0 PURPOSE**

The purpose of this policy is to outline the Athens Utilities Board (AUB) Natural Gas Distribution System established gas rates.

**2.0 SCOPE**

This policy applies to all gas accounts serviced by the AUB.

**3.0 REFERENCES**

- (1) Athens Utilities Board Division of Gas, rate schedules

**4.0 GENERAL**

Residential, commercial and industrial single use accounts are subject to the gas use rates as defined in *Section 6.0* of this Policy.

**5.0 DEFINITIONS**

**AUB** – means the Athens Utilities Board, and its duly authorized employees, agents, and representatives

**Board** – means the Chairman and all Commissioners but does not include any employees

**BTUH** – The measurement of heat value of natural gas as defined by the British Thermal Unit per Hour

**Customer** – Any person, business, or other entity that receives natural gas service from Athens Utilities Board, Division of Natural Gas

**Division** – The Athens Utilities Board, Division of Gas

**Installer** – A bonded gas fitter as on file with AUB

**Local Control Authority** – Superintendent of Gas or duly authorized representative

**Service Connection** – Shall mean the tap of the main and that portion of the line extending from the tap of the main to and including the meter and meter installation.

## **6.0 POLICY/PROCEDURES**

### **6.1 Statement of Rate**

The Board establishes rates and may change from time to time in order to meet the needs of the Division. See AUB Schedule of Rates and Fees.

#### **Gross Rate:**

The net rates listed in the AUB Schedule of Rates and Fees will apply if payment is made on or before due date shown on bill. The gross rate (net rate plus 5%) will apply if paid at a later date.

#### **Policies and Procedures**

All service under these schedules is subject to the policies and procedures, as amended, of Athens Utilities Board, Division of Gas.

#### **Single-Point Delivery**

The above rates are based upon supply of service to the customer's premises through a single delivery and metering point, and at a single pressure. Separate supply for the same customer at other points of consumption, or at different pressures, shall be separately metered and billed.

#### **Supply Curtailment**

AUB is subject to supply curtailment invoked by its supplier, in accordance with orders from the various governmental agencies having jurisdiction over natural gas supply. AUB will curtail service under this rate as required depending on available supplies and governmental orders.

Special contract rates may be negotiated to cover nonstandard service including but not limited to natural gas transportation, special emergency purchases, propane air conversion and propane transportation. Special contracts will be specified in nature and on an individual basis depending on special customer requirements and available supplies.

#### **Contract Requirements**

Customers obtaining natural gas service under rate schedule 62A will be required to execute written contracts for a period of not less than two years. Contracts for other service rates may be initiated at the discretion of the AUB Local Control Authority.

Athens Utilities Board

<b>Division of Gas – Policies and Procedures Manual Standard Policies and Procedures</b>	
<b>Policy Number – AUB-03-04</b>	<b>Revision Number: 4</b>
<b>Subject Gas Service Line and Fee</b>	<b>Effective Date: 07-01-2013</b>
	<b>Superintendent Approval:</b>
	<b>General Manager Approval:</b>

**1.0 PURPOSE**

The purpose of this policy is to outline the Athens Utilities Board (AUB) Natural Gas Distribution System gas service line policy and fee schedule.

**2.0 SCOPE**

This policy applies to all existing and future gas accounts serviced by the AUB.

**3.0 REFERENCES**

(1) Athens Utilities Board, Division of Gas, Rules and Regulations and Extension Policies

**4.0 GENERAL**

Future connections to AUB’s Natural Gas Distribution System are required to be coordinated through the local control authority for AUB. All policy requirements listed in *Section 6.0* and fees are applicable to new gas connections.

**5.0 DEFINITIONS**

**AUB** – means the Athens Utilities Board, and its duly authorized employees, agents, and representatives

**Board** – means the Chairman and all Commissioners but does not include any employees

**BTUH** – The measurement of heat value of natural gas as defined by the British Thermal Unit per Hour

**Customer** – Any person, business, or other entity that receives natural gas service from Athens Utilities Board, Division of Natural Gas

**Division** – The Athens Utilities Board, Division of Gas

**Installer** – A bonded gas fitter as on file with AUB

**Local Control Authority** – Superintendent of Gas or duly authorized representative

**Service Connection** – Shall mean the tap of the main and that portion of the line extending from the tap of the main to and including the meter and meter installation.

## 6.0 POLICY/PROCEDURES

### 6.1 General Policy/Procedures all service lines

Customers are required to visit the Customer Service Center in the Athens Utilities Board office, located at 100 New Englewood Road, Athens, TN. All customers must provide AUB with the following:

1. Customer name,
2. Billing and mailing address,
3. Telephone number,
4. Picture I.D., and
5. Classification of tap to be installed.

A work order will be generated for service line installation. Taps will be installed on a first come first serve basis.

The cost of installation must be paid in advance unless otherwise denoted in the AUB Schedule of Rates and Fees. Any maintenance and/or replacement cost would be billed at the time work is done.

The service line and meter will be located at the utility's discretion. The location will be such that the meter and connections are accessible to be read or changed. The customer may not encumber the meter set with plants, shrubs, fences or in any way that will inhibit the Athens Utilities Board's ability to read and maintain the meter set. The Division avoids installing a service line under paved or concrete driveways. The easiest route for service line installation will be chosen.

It is the responsibility of the customer to inform the Division of the presence and location of any and all known buried utilities located on the customer's property. The Division will not be held liable for damages incurred to said utilities that are not correctly located.

If the customer wishes to proceed and have natural gas installed, the tap fees shall be paid accordingly and the Division will schedule installation based upon availability. A service line will then be installed from the main to the meter set. The customer is responsible to have the piping and appliances installed in residence receiving service. After home piping is complete and appliances have been installed, the customer must contact the Division to arrange an inspection and to have the lock removed from the meter. ***Under no circumstances*** will a contractor or homeowner be allowed to operate, unlock, or tamper with a meter. ***Under no circumstances*** will a homeowner or contractor use any gas in any way except through an inspected and accepted piping/appliance system.

Customers who wish to have their service line or meter set moved or modified due to remodeling or some other customer convenience will be charged a relocation fee as stipulated in AUB Schedule of Rates and Fees, or materials and labor, whichever is greater. The customer in no case will be permitted to move or modify the tap or meter set.

The lines and meter set are the property of AUB. The customer may not encumber AUB's access to the lines or meter set.



## **6.2 Residential**

Fee will be determined by the footage of the service line from the property line to the meter set in accordance with the Board's established tap fees (See AUB Schedule of Rates and Fees).

Residential systems are typically designed to operate at four ounces pressure per square inch gage. Systems designed to operate at two pounds pressure per square inch gage will be installed in accordance with the International Fuel Gas Code.

A bonded gas fitter certified in the specific materials being utilized must install installation of systems in accordance with the International Fuel Gas Code.

## **6.3 Small Commercial**

Small commercial service will be charged in accordance with the Board's established tap fees (See AUB Schedule of Rates and Fees).

Systems designed to operate at two pounds pressure per square inch gage will be installed in accordance with the International Fuel Gas Code

A bonded gas fitter certified in the specific materials being utilized must install installation of systems in accordance with the International Fuel Gas Code . Welding Certification(s) must be on file with the Division before the work is accepted.

## **6.4 Large Commercial and Industrial**

Large commercial and industrial service will be charged in accordance with the Boards established tap fees (See AUB Schedule of Rates and Fees).

Systems designed to operate at two or five pounds pressure per square inch gage will be installed in accordance with the International Fuel Gas Code .

A bonded gas fitter certified in the specific materials being utilized must install installation of systems. Welding Certification(s) must be on file with the Division before the work is accepted. All welded systems will be pressure tested at 20 PSI or above.

## **6.5 Variances From and Effect of Preceding Rules as to Extensions**

The sections above have been adopted by AUB with the knowledge of the distribution system of the Division of Gas. It is anticipated that these policies can be revised and simplified from time to time as needed improvements are made.

Effective 07/01/13

The authority to install gas service lines pursuant to the Sections above is permissive only. Nothing contained therein shall be construed to require AUB to install gas service to furnish service to any person or persons, even though such prospective customers meet all of the requirements contained in the Sections above.

**Athens Utilities Board**

<b>Division of Gas – Policies and Procedures Manual Standard Policies and Procedures</b>	
<b>Policy Number – AUB-03-05</b>	<b>Revision Number: 4</b>
<b>Subject Gas Appliance Policy and Fees</b>	<b>Effective Date: 10-01-2009</b>
	<b>Superintendent Approval:</b>
	<b>General Manager Approval:</b>

**1.0 PURPOSE**

The purpose of this policy is to notify all existing and future users of the Athens Natural Gas Distribution System of the gas appliance policy and fees for the Athens Utilities Board.

**2.0 SCOPE**

This policy applies to all existing and future gas accounts serviced by the Athens Utilities Board.

**3.0 REFERENCES**

- (1) Athens Utilities Board, Division of Gas, Rules and Regulations and Extension Policies
- (2) International Fuel Gas Code
- (3) American Gas Association Design criteria 3-87, ANSI Z21.24, ANSI Z21.45 and CAN/CGA 6.10-M88

**4.0 GENERAL**

Appliances purchased from the Athens Natural Gas Division are required to coordinate through the local control authority for AUB. All policy requirements listed in **Section 6.0** and fees are applicable to gas connections.

**5.0 DEFINITIONS**

**AUB** – Means the Athens Utilities Board, Division of Gas, and its duly authorized employees, agents, and representatives.

**Board** – Means the Chairman and all Commissioners but does not include any employees.

**BTUH** – The measurement of heat value of natural gas as defined by the British Thermal Unit per Hour.

**Customer** – Any person, business, or other entity that receives natural gas service from Athens Utilities Board, Division of Natural Gas.

**Division** – The Athens Utilities Board, Division of Gas.

**Installer** – A bonded gas fitter.

**Local Control Authority** – Superintendent, Division of Natural Gas or duly authorized representative.

**Service Connection** – Shall mean the tap of the main and that portion of the line extending from the tap of the main to and including the meter and meter installation.

## **6.0 POLICY/PROCEDURES**

### **6.1 Residential Appliances**

The AUB Natural Gas Division provides sales of certain appliances for its customers. Appliance types, styles and manufacturers may change from time to time. AUB will provide for installation of appliances at the customer's request.

Customers are required to visit the Customer Service Center in the Athens Utilities Board offices, located at 100 New Englewood Road, Athens, TN. After the clerk has been given the customer name, billing and mailing address, telephone number, and pictorial I.D., a work order will be generated to determine the fees for the gas tap at the requested residence. Fees will be determined by the cost of the appliance and its installation in accordance with *Section 7.0 of this policy*. The customer will be billed the applicable fees.

The cost of installation may be paid in advance or may be paid on a monthly basis. Any maintenance and/or replacement cost would be billed at the time future work is done.

The appliance will be located pursuant to the customer's request and in accordance with the guidelines of the Southern Building Code.

It is the responsibility of the customer to inform the Division of the presence and location of any and all known encumbrances to the appliance and its associated materials on the customer's property. The Division will not be held liable for damages incurred to said encumbrances, which are not correctly located.

If the customer wishes to proceed and have natural gas appliances installed, the terms of payment shall be established accordingly and the Division will schedule installation based upon availability. Appliances will then be installed. After home piping is complete and appliances have been installed, the customer will reimburse the Division pursuant to the agreed method of payment. Failure to complete payment will result in the removal of the appliance(s), but does not release the customer from obligation to complete the agreed payment of all cost between recovered value of the appliances and their installation and the remaining amount owed.

Customers who wish to have their appliances and or associated materials moved or modified due to remodeling or some other customer convenience will be charged materials and labor.

### **6.2 Commercial and Industrial Appliances**

All industrial or commercial appliances will be charged the cost of the appliance and all materials and labor for installation. The Division will, upon request, furnish estimates based on their best information but will not be held to the limits of the estimate.

### **6.3 Variances From and Effect of Preceding Rules as to Appliances**

The sections above have been adopted by AUB with the knowledge of the Division of Natural Gas. It is anticipated that these policies can be revised and simplified from time to time as needed improvements are made.

Effective 07/01/13

## **7.0 APPLIANCE FEES**

The following are minimum gas appliance fees for new installations or renovations:

1. Retail cost of appliance
2. Actual or fixed (as determined by contractual negotiations with designated contractors.)
3. Promotional fee reduction or fee elimination may be offered from time to time.

Athens Utilities Board

<b>Division of Gas – Policies and Procedures Manual Standard Policies and Procedures</b>	
<b>Policy Number – AUB-03-06</b>	<b>Revision Number: 4</b>
<b>Subject Excess Flow Valve Installation and Maintenance</b>	<b>Effective Date: 07-01-2013</b>
	<b>Superintendent Approval:</b>
	<b>General Manager Approval:</b>

**1.0 PURPOSE**

The purpose of this policy is to outline Athens Utilities Board’s (AUB) policy involving the installation and use of excess flow valves for natural gas lines.

**2.0 SCOPE**

This policy applies to all new and existing customers purchasing natural gas from AUB.

**3.0 REFERENCES**

- (1) Athens Utilities Board, Division of Gas, Rules and Regulations and Extension Policies
- (2) International Fuel Gas Code
- (3) 49 CFR 192

**4.0 GENERAL**

Excess flow valves shall be installed and maintained in conjunction with this policy and AUB procedure *AUB-03-02, Meter and Line Extension Policy*.

**5.0 DEFINITIONS**

**AUB** – means the Athens Utilities Board, and its duly authorized employees, agents, and representatives

**Board** – means the Chairman and all Commissioners but does not include any employees

**BTUH** – The measurement of heat value of natural gas as defined by the British Thermal Unit per Hour

**Customer** – Any person, business, or other entity that receives natural gas service from Athens Utilities Board, Division of Natural Gas

**Division** – The Athens Utilities Board, Division of Gas

**Installer** – A bonded gas fitter as on file with AUB

**Local Control Authority** – Superintendent of Gas or duly authorized representative

**Service Connection** – Shall mean the tap of the main and that portion of the line extending from the tap of the main to and including the meter and meter installation.

## **6.0 POLICY/PROCEDURES**

### **6.1 General Requirements**

The AUB Natural Gas System is required to comply with all Pipeline Safety Regulations as set forth in 49 CFR 192.53.

When a service line serving only one residential customer is installed or replaced, 49 CFR Section 192.383 requires the Utility to install an excess flow valve on that service line. An excess flow valve is intended to stop the flow of gas should the flow exceed a set rate such as when the service line is broken by construction or other accidents.

### **6.2 Customer Responsibilities**

1. Installation of an excess flow valve is mandatory.
2. The customer shall bear the initial set costs of installation..
3. An excess flow valve will not protect against the following events:
  - a. Customer appliance gas leaks
  - b. Small gas service-line punctures
  - c. Gas meter-set leaks
4. AUB Gas Division makes no warranty for continued proper excess flow valve operation under normal use conditions and/or false valve closure under any gas system operating conditions.

Athens Utilities Board

<b>Division of Gas – Policies and Procedures Manual Standard Policies and Procedures</b>	
<b>Policy Number – AUB-03-07</b>	<b>Revision Number: 4</b>
<b>Subject Gas Central Heat Loan Policy</b>	<b>Effective Date: 10-01-2009</b>
	<b>Superintendent Approval:</b>
	<b>General Manager Approval:</b>

**1.0 PURPOSE**

The purpose of this policy is to notify all existing and future users of the Athens Natural Gas Distribution System of the gas central heat loan policy and fees for the Athens Utilities Board.

**2.0 SCOPE**

This policy applies to all existing and future gas accounts serviced by the Athens Utilities Board.

**3.0 REFERENCES**

None

**4.0 GENERAL**

Central heat units purchased from approved vendors are required to coordinate through the local control authority for AUB. All policy requirements listed in *Section 6.0* and fees are applicable to gas connections.

**5.0 DEFINITIONS**

**AUB** – Means the Athens Utilities Board, Division of Gas, and its duly authorized employees, agents, and representatives.

**Board** – Means the Chairman and all Commissioners but does not include any employees.

**BTUH** – The measurement of heat value of natural gas as defined by the British Thermal Unit per Hour.

**Customer** – Any person, business, or other entity that receives natural gas service from Athens Utilities Board, Division of Natural Gas.

**Division** – The Athens Utilities Board, Division of Gas.

**Installer** – A bonded gas fitter.

**Local Control Authority** – Superintendent, Division of Natural Gas or duly authorized representative.

**Service Connection** – Shall mean the tap of the main and that portion of the line extending from the tap of the main to and including the meter and meter installation.



## **6.0 POLICY/PROCEDURES**

### **6.1 Residential Central Heat Units**

The AUB Natural Gas Division provides a list of approved vendors for its customers. Approved vendors may change from time to time. Vendors will provide central heating unit, service, and its installation.

Customers are required to visit the Customer Service Center in the Athens Utilities Board offices, located at 100 New Englewood Road, Athens, TN. After the clerk has been given the customer name, billing and mailing address, telephone number, pictorial I.D., and social security number a loan application will be generated to determine the customer's credit worthiness.

Approved loan applications will require the customer's signature. Loan amounts will be determined by the customer's selected vendor and will include the cost of equipment and installation. The customer will be billed cost of the equipment and its installation in accordance with *Section 7.0 of this policy*.

Customer's who are denied loans will be notified via first class mail within ten days in accordance with State and Federal law. The reasons for loan denial will be noted along with the name and signature of the person making the decision. Denials based on credit reports will include information indicating how the customer can contact the credit-reporting agency.

It is the responsibility of the customer's selected vendor to inform the Division of estimated start and finish times of installation. The Division's representative will inspect the installation. AUB will disburse funds to the vendor for installations meeting the Division's approval. The Division will not be held liable for damages incurred during installation.

A fixture lien document (UCC-1) will be filed with the county's Register of Deeds.

### **6.2 Variances From and Effect of Preceding Rules as to Appliances**

The sections above have been adopted by AUB with the knowledge of the Division of Natural Gas. It is anticipated that these policies can be revised and simplified from time to time as needed improvements are made.

### **7.0 Central Heat Unit Loan Fees**

Loans will be made with interest based on AUB's determined fair rate of return. The duration of the loan repayment program will be based on a term agreeable to both the loan recipient and the Division.

Athens Utilities Board

<b>Division of Gas – Policies and Procedures Manual Standard Policies and Procedures</b>	
<b>Policy Number – AUB-03-08</b>	<b>Revision Number: 4</b>
<b>Subject Gas Water Heater Lease Policy and Fees</b>	<b>Effective Date: 10-01-2009</b>
	<b>Superintendent Approval:</b>
	<b>General Manager Approval:</b>

**1.0 PURPOSE**

The purpose of this policy is to notify all existing and future users of the Athens Natural Gas Distribution System of the natural gas water heater lease policy and fees for the Athens Utilities Board.

**2.0 SCOPE**

This policy applies to all existing and future gas accounts serviced by the Athens Utilities Board.

**3.0 REFERENCES**

None

**4.0 GENERAL**

Natural gas water heaters leased from the Athens Natural Gas Division are required to coordinate through the local control authority for AUB. All policy requirements listed in *Section 6.0* and fees are applicable to gas connections.

**5.0 DEFINITIONS**

**AUB** – Means the Athens Utilities Board, Division of Gas, and its duly authorized employees, agents, and representatives.

**Board** – Means the Chairman and all Commissioners but does not include any employees.

**BTUH** – The measurement of heat value of natural gas as defined by the British Thermal Unit per Hour.

**Customer** – Any person, business, or other entity that receives natural gas service from Athens Utilities Board, Division of Natural Gas.

**Division** – The Athens Utilities Board, Division of Gas.

**Installer** – A bonded gas fitter.

**Local Control Authority** – Superintendent, Division of Natural Gas or duly authorized representative.

**Service Connection** – Shall mean the tap of the main and that portion of the line extending from the tap of the main to and including the meter and meter installation.

## **6.0 POLICY/PROCEDURES**

### **6.1 Natural Gas Water Heaters Leased**

The AUB Natural Gas Division provides the lease to own of natural gas water heaters and its installation for its customers. Natural gas water heater types, styles and manufacturers may change from time to time.

Customers are required to visit the Customer Service Center in the Athens Utilities Board offices, located at 100 New Englewood Road, Athens, TN. After the clerk has been given the customer name, billing and mailing address, telephone number, and pictorial I.D., a work order will be generated to determine the fees for the installation of the natural gas water heater at the requested residence. Fees will be determined by the cost of the appliance and its installation in accordance with *Section 7.0 of this policy*. The customer will be billed the applicable fees.

The cost of installation may be paid in advance or may be leased to own with payment on a monthly basis.

The natural gas water heater will be located pursuant to the customer's request where possible and in accordance with the guidelines of the Southern Building Code.

It is the responsibility of the customer to inform the Division of the presence and location of any and all known encumbrances to the natural gas water heater and its associated materials on the customer's property. The Division will not be held liable for damages incurred to said encumbrances, which are not correctly located.

If the customer wishes to proceed and have the natural gas water heater installed, the terms of lease shall be established based on the Division's cost of installation, the cost of the natural gas water heater and a rate of return acceptable to AUB. Lease terms shall not exceed forty-seven months. The forty-eighth month the customer shall purchase the natural gas water heater. The Division will provide service of the natural gas water heater during the term of the lease.

The Division will schedule installation based upon availability. The natural gas water heaters will then be installed. After home piping is complete and the natural gas water heater has been installed, the customer will reimburse the Division pursuant to the agreed lease payment. Failure to complete payment will result in the removal of the natural gas water heater, but does not release the customer from obligation to complete the agreed payment of all cost between recovered value of the natural gas water heater and its installation and the remaining amount owed.

Customers who elect to abandon or sell their residence will be responsible for any remaining monthly lease payments and the final purchase payment.

Customers who wish to have the natural gas water heater and or associated materials moved or modified due to remodeling or some other customer convenience will be charged a minimum of two hundred-fifty (\$250) dollars or materials and labor, whichever is greater.

## **6.2 Commercial and Industrial Appliances**

All industrial or commercial natural gas water heaters will be charged the cost of the appliance and all materials and labor for installation. The Division will, upon request, furnish estimates based on their best information but will not be held to the limits of the estimate.

## **6.3 Variances From and Effect of Preceding Rules as to Appliances**

The sections above have been adopted by AUB with the knowledge of the Division of Natural Gas. It is anticipated that these policies can be revised and simplified from time to time as needed improvements are made.

## **7.0 Appliance Fees**

The following are minimum gas appliance fees for new installations or renovations:

1. Retail cost of the natural gas water heater
2. Actual or fixed (as determined by contractual negotiations with designated contractors.)
3. AUB's fair rate of return
4. Promotional fee reduction or fee elimination may be offered from time to time.

Effective 07/01/13

## **Addendum 03-01-01**

Deposit No. \_\_\_\_\_ Power   
 Deposit No. \_\_\_\_\_ Gas   
 Deposit No. \_\_\_\_\_ Water

**STANDARD APPLICATION FOR SERVICE**  
**ATHENS UTILITIES BOARD**  
**ATHENS, TENNESSEE**

Name \_\_\_\_\_ Date \_\_\_\_\_

Billing Address \_\_\_\_\_ Residential   
 Commercial

Service Address \_\_\_\_\_

Folio No.	M. O. No.	Date	Folio No.	M. O. No.	Date
_____	_____	_____	_____	_____	_____
_____	_____	_____	_____	_____	_____
_____	_____	_____	_____	_____	_____

Signed \_\_\_\_\_ By \_\_\_\_\_

**Applicant**  
**(Provisions on back, apply to this application)**

The undersigned makes application for Utilities Services at the service address shown on this application and thereby agrees to pay for said services as measured by Athens Utilities Board (AUB) meters according to applicable rates.

The applicant agrees to permit authorized agents of AUB free access to the subject premises to inspect, maintain, repair, or replace AUB property; read AUB meters; and/or remove obstructions or encumbrances so as to maintain required clearances for the safe and proper operation of AUB property.

AUB shall have the right, but shall not be obligated, to inspect installations before introducing service, or at any later time, and reserve the right to reject installations or appliances not installed in accordance with AUB standards; such inspection or lack thereof, or rejection, shall not render AUB liable or responsible for any loss or damage resulting from defects in installations or from violation of AUB rules and regulations, as amended, or from accidents that may occur upon the customer's premises.

The applicant agrees that his application is subject to AUB Rules and Regulations, as amended, copies of which are open for inspection at AUB offices, and that these Rules and Regulations as amended are part of this agreement.

The applicant expressly agrees that in the event any amount is due and owing to any AUB Division (Power, Water/Wastewater, or Gas) for a period of ten (10) days after the billing date, AUB is authorized to discontinue service to the applicant by any or all Divisions, and applicant hereby waives any claims for damage accruing by reason of such discontinuation of services.

Effective 07/01/13

## **Addendum 03-01-02**

DATE: \_\_\_\_\_

WORKORDER: \_\_\_\_\_

ACCOUNT #: \_\_\_\_\_

**APPLICATION FOR GAS SERVICE LINE**

I, the undersigned, hereby request **ATHENS UTILITIES BOARD, DIVISION OF GAS**, to extend gas service to \_\_\_\_\_ located at \_\_\_\_\_.

Easement rights for the installation and subsequent necessary inspections of the service line are hereby granted to **ATHENS UTILITIES BOARD**. It is further understood that no claim shall be placed against **ATHENS UTILITIES BOARD** as a result of the installation of the gas service line.

I understand that I shall pay the gas line installation fee of **\$300.00**, as well as the gas service charge of **\$25.00** and deposit (if applicable) at the time of applying for service. Fee includes first 100 feet of installed gas line. For longer service lines, additional footage is \$1.00/ft. Footage credits will be applied for each online gas appliance installed. Credits will be applied to your customer account and inspections should be made within 90 days or one year for new construction.

**PROPERTY OWNER** \_\_\_\_\_

**BILLING ADDRESS** \_\_\_\_\_  
\_\_\_\_\_

**PHONE** \_\_\_\_\_

**GAS FOOTAGE CREDITS: Primary Heat- 200, Water Heater- 200, Dryer- 200, Range- 150, Unvented logs- 150, Vented logs- 100, Space Heater- 150, Outdoor Grill- 100, Pool Heater- 200, Outdoor Lighting- 150**

<b>METER ORDER #</b> _____	<b>SERVICE CHARGE PAID</b> ___ YES
___ NO	
	<b>LINE INSTALLATION PAID</b> ___ YES
	___ NO
<b>NEW CONSTRUCTION</b> ___ YES ___ NO	<b>IF YES,</b>
<b>IS ALL GRADE WORK AROUND STRUCTURE COMPLETE</b>	___ YES ___ NO



Effective 07/01/13

## **Addendum 03-01-03**

**NATURAL GAS SERVICE INFORMATION**

**ATHENS UTILITIES BOARD  
DIVISION OF GAS  
ATHENS, TENNESSEE**

**APRIL 1, 2000  
REVISED October 1, 2009  
REVISED July 1, 2013**

**SHERREE REED  
SUPERINTENDENT**

## NATURAL GAS SERVICE INFORMATION

### 1. SERVICE LINE

- 1.A. Come by our Customer Service Center in the Athens Utilities Board office, located at 100 New Englewood Road, Athens, TN. Give the clerk your name, billing and mailing address, telephone number, and pictorial I.D.
- 1.B. A work order will be generated to install the gas service line at your residence after the service line fees are received.
- 1.C. AUB will collect the following charges at the time you apply for the new gas service:
  - 1) Service line and meter set fee per AUB Schedule of Rates and Fees.
  - 2) Our natural gas system is required to comply with all Pipeline Safety Regulations as set forth in 49 CFR 1.53, Part 192.  
When a service line serving only one residential customer is installed or replaced, Section 192.383 requires the Utility to install an EXCESS FLOW VALVE on the service line. An EXCESS FLOW VALVE is intended to stop the flow of gas should the flow exceed a set rate such as when the service line is broken by construction or other accidents. The cost of installation must be paid in advance in the amount of One Hundred Dollars (\$100).
- 1.D. The meter will be located at the utility's discretion. The location will be such that the meter and connections are accessible in order that the meter may be read or changed. The customer may not encumber the meter set with plants, shrubs, fences or in any way that will inhibit the Athens Utilities Board's ability to read and maintain the meter set. The Division avoids installing a service line under paved or concrete driveways. The easiest route for service line installation will be chosen.
- 1.E. It is the responsibility of the customer to inform the Division of the presence and location of any and all known buried utilities located on the customer's property. The Division will not be held liable for damages incurred to said utilities, which are not correctly located.
- 1.F. If you wish to proceed and have natural gas installed, the Division will add you to the queue of installation. A service line will then be installed from the main to the meter set. You will then be billed for the cost of installation. The amount of your service line fee will be determined by addendum 03-05-01. From that point of connection at the meter you are then responsible for having the piping and appliances installed into your home or business. After your piping is complete and appliances have been installed you must contact the Division to arrange an inspection and to have the lock removed from the meter. In no circumstance will a contractor or homeowner be allowed to operate, unlock, or tamper with a meter. In no circumstance will a homeowner or contractor use any gas in any way except through an inspected and accepted piping/appliance system.

- 1.G. Customers who wish to have their service line or meter set moved or modified due to remodeling or some other customer convenience will be charged a relocation fee. The customer in no case will be permitted to move or modify the service line or meter set.
- 1.H. The lines and meter set are the wholly owned property of Athens Utilities Board. The customer can in no way encumber AUB's access to the lines or meter set.

## **2. BILLING**

- 2.A. Natural gas usage is billed per therms.
- 2.B. There is a monthly availability charge, which begins to accrue immediately after the service line is installed and a meter set.
- 2.C. A statement of account per customer will be rendered monthly and shall be paid by the due date as shown on the bill. Failure to receive the bill will not release the customer from payment obligation. Bills paid on or before the due date of payment shall be payable at the net rate; thereafter, the gross rate (net amount plus five (5%) percent) shall apply. Should the due date for payment of the bill at the net rate fall on a Saturday, Sunday or holiday, the business date next following the final date will be held as a day of grace for payment of bill. Net rate remittance received by mail after the time limit for payment of said net rate will be accepted by the Utility if the incoming envelope bears U.S. Postal date stamp of the due date for payment of the net amount or any prior date. Night depository receipts will be accepted if received by 7.30 a.m., on the morning following the due date of the bill. All charges are subject to a penalty of five percent of the amount of charges when they are not paid by the specified due date.

## **3. REGULATORY AUTHORITY**

- 3.A. The Division shall utilize the standards as developed by the Tennessee Regulatory Authority, The United States Department of Transportation, and the International Fuel Gas Code. Information contained in this document is derived from these sources. Questions concerning regulatory/code concerns not covered in this document should be referred to the referenced governing authorities.

## **4. CUSTOMER SUPPLIED PIPING**

- 4.A. All consumers piping must be installed by a Bonded Gas Fitter. A list of Bonded Gas Fitters is attached to this document.
- 4.B. After your piping is installed contact the Gas Division, and an inspector will be sent to inspect your fuel line, appliance venting/installation, and turn on your gas service. Your bonded gas fitter must at this time present written proof that the installation has been pressure tested, in accordance with division guidelines, prior to installing the appliances.
- 4.C. The customer owns and is responsible for the gas distribution system in his home or business. As part of the consideration for this installation, the natural gas

customer does hereby release the Athens Utilities Boards Gas Division from any and all claims for damages from whatsoever cause incidental to the installation or operation of the customers piping, appliances or use of natural gas.

- 4.C. Inspections furnished by the Division are for the good use of the Gas Division only.

## **5. PIPE INSTALLATION**

- 5.A. The Installer shall be a Bonded Gas Fitter and be qualified to adequately size the customer's piping in accordance with the International Fuel Gas Code. Piping shall be of such size and so installed as to provide a supply of gas sufficient to meet maximum demand without undo loss of pressure between the point of delivery and gas appliances/equipment. Actual appliance demand should be used to size the supply system.
- 5.B. Buried black iron must be welded and cathodically protected from corrosion. Plastic pipe (MDPE 2406-ASTM 2513) may be installed. The plastic pipe installer must have certification in natural gas plastic pipe heat fusing. Tracing wire must be buried with plastic lines. Minimum soil cover for all buried lines shall be 12 inches. No gas piping shall be placed underground closer than 12 inches from water, drainage, electrical or sewer lines. Laying or installing gas piping in the same ditch as water, sewer, electricity or drainage is prohibited. All buried piping will be left exposed for inspection prior to covering. AUB is not responsible for any maintenance of the customer's buried piping.
- 5.C. Drip legs shall be provided per manufacturer's guidelines

## **6. TEST OF PIPING FOR TIGHTNESS**

- 6.A. Before a customer's gas piping system is placed into service, it shall be carefully tested by a Bonded Gas Fitter, to assure that it is gas tight. If repairs or additions are made following the pressure test, the affected piping shall again be tested. The piping shall be tested with air or inert gas. The pressure test is the responsibility of the installer. The installer must present written proof to the customer and the Division that the test was performed successfully.
- 6.B. Customer's gas piping shall withstand a pressure of at least 20 psig for a minimum of 120 minutes without showing a drop in pressure. A minimum 50-psi gauge is required for this test.
- 6.C. The Bonded Gas Fitter will be assessed a service charge for each inspection beyond the first inspection. The service charge will be in accordance with fees listed in the applicable AUB Rates and Fees Schedule.
- 6.D. The Bonded Gas Fitter assumes full responsibility for any and all operation, correction or damages caused by operation or testing of the customer's gas piping, before, during, and after any testing by the Division. As part of the consideration for this installation, the natural gas customer does hereby release AUB from any and all claims for damages from any causes incidental to the installation or operation of a customer's piping, appliances, equipment or use of natural gas.

- 6.E The pressure test is for the good use of AUB only, and provides no guarantee of any kind. The bonded gas fitter must complete the form available in the Pressure Testing Policy, *Addendum 03-02-01*.

## **7. TURNING ON GAS**

- 7A. The contractor may turn on gas to the home after the Division has reviewed testing certification and has turned on gas at the meter set. Before turning on gas, close all openings from which gas can escape. Immediately after turning the system on, a thorough check must be made at all joints to check for leaks using a leak detection solution.
- 7B. After the pipe has been checked for leakage, it shall be purged of all air until gas is present. Never purge a system into the combustion chamber of an appliance.
- 7C. Purge appliance and light pilot.

## **8. APPLIANCE INSTALLATION**

- 8.A. Appliances will be installed according to manufacturer's guidelines and the International Fuel Gas Code. **VENTING**
- 8.B. All venting shall conform to the International Fuel Gas Code and manufacturer's guideline.

## **9. UNVENTED ROOM HEATERS**

- 9.A. An unvented room heater is allowed. Installations must be in accordance with manufacturer's guidelines and International Fuel Gas Code.
- 9.B. The division requires a carbon monoxide detector be installed in each room where an unvented appliance is installed.

## **10. PILOT LIGHTING SEASON**

- 10.A. There is a charge (see AUB Schedule of Rates and Fees) to have your pilot lit in the fall and each subsequent light up afterwards.

## **Addendum 03-01-04**

## **FEDERAL SAFETY REGULATION – EXCESS FLOW VALVE**

### **APPLICATION FOR GAS SERVICE LINE**

The Federal Department of Transportation is now enforcing a new safety regulation pertaining to ‘EXCESS FLOW VALVES.’ Accordingly, we are required to notify customers on new or replaced gas service lines of mandatory installation of an excess flow valve that meets minimum Federal performance requirements.

### **WHAT IS AN EXCESS FLOW VALVE?**

An excess flow valve is a device designed to restrict gas flow in a customer’s natural gas service line by automatically closing in the event that a service line is broken, completely cut, torn apart or otherwise separated, usually caused by some type of excavation or digging. Restricting gas flow after a gas service line is damaged may decrease the potential for property damage and/or injury.



## **Addendum 03-02-01**

ATHENS UTILITIES BOARD  
Required Pressure Testing Procedure

All pressure testing must be done by a Bonded Gas Fitter. PLEASE PRESENT THIS COMPLETED FORM TO THE DIVISION INSPECTOR WHEN INSPECTION AND GAS IS TO BE TURNED ON. Before any system of consumer's gas piping is finally put into service, it shall be carefully tested to assure that it is gas tight. If repairs or additions are made following the pressure test, the affected piping will again be tested. Where any part of the system is to be enclosed, the test should precede the work of closing in. To test for tightness the piping shall be tested with air or inert gas. The pressure test is the responsibility of the installer. The installer must be a Bonded Gas Fitter. The installer must present written proof to the owner and the Division that the test was performed successfully. When additional inspections are required, the bonded gas fitter will be assessed, a \$25 service charge per each additional inspection.

The installer assumes full responsibility for any and all operation, correction, or damages caused by operation or testing of the customer's gas piping before, during or after any testing by the Division. As part of the consideration for this installation, the natural gas customer does hereby release the Athens Utilities Board – Division of Gas from any and all claims for damages from whatsoever causes incidental to the installation or operation of a customer's piping, appliances, or use of natural gas.

Method – Consumer's gas piping shall withstand a pressure of at least 20 psi for a least 120 minutes without showing a drop in pressure. A 50 psi gauge is required for this test so that even a minute loss of pressure can be detected.

The pressure test is for the good use of the Division only, and provides no guarantee of any kind.

I \_\_\_\_\_, a Bonded Gas Fitter, have installed the gas system

at \_\_\_\_\_ in accordance with the installation procedures of the Athens Utilities Board – Division of Gas, The International Fuel Gas Code, and the appliance manufacturer instructions and listings. I also attest that I have performed the above pressure test correctly and have found no leaks.

Date: \_\_\_\_\_ Company Name:

\_\_\_\_\_

Employee Name: \_\_\_\_\_

\_\_\_\_\_

Print

Signature

The customer owns and is responsible for the gas distribution system in his/her home. As part of the consideration for this installation, the natural gas customer does hereby release the Athens Utilities Board – Division of Gas from any and all claims for damages from whatsoever cause incidental to the installation, testing, or operation of the customers piping,

Effective 07/01/13

appliances, or use of natural gas. The above pressure testing is for the good use of the Division only, and provides no guarantee of any kind.

Customer: \_\_\_\_\_ Address:

\_\_\_\_\_

Customer Signature:

\_\_\_\_\_

Effective 07/01/13

***Division of Water – Policies and Procedures Manual  
Standard Policies and Procedures  
Table of Contents***

AUB-01-01	Obtaining Water Service	178
AUB-01-02	Fire Hydrant Installation and Use	182
AUB-01-03	Development Extension Policy	185
AUB-01-04	Water Rate Schedule	190
AUB-01-05	Water Adjustment Policy	193
AUB-01-06	Water Tap Policy and Fee	197
AUB-01-07	Cross Connections, Auxiliary Intakes, Bypasses and Interconnections	202
AUB-01-08	Forms/Drawings Specifications for Division of Water	205

Athens Utilities Board

<b>Division of Water – Policies and Procedures Manual Standard Policies and Procedures</b>	
<b>Policy Number – AUB-01-01</b>	<b>Revision Number: 5</b>
<b>Subject Obtaining Water Service</b>	<b>Effective Date: 07-01-13</b>
	<b>Superintendent Approval:</b>
	<b>General Manager Approval:</b>

**1.0 PURPOSE AND SCOPE**

The purpose of this policy is to outline the requirements associated with obtaining water service from Athens Utilities Board (AUB). This policy applies to all existing and potential water accounts serviced by the Athens Utilities Board.

**2.0 REFERENCES**

- (1) Athens Utilities Board Division of Water, Policies and Procedures Manual

**3.0 GENERAL**

A formal application for original or additional service must be made at the offices of AUB or with a duly appointed agent of AUB and be duly approved before service connection. A meter will not be set or service connected before payment of the service line installation charge and any additional applicable charges and deposits are made.

Any exceptions to this policy will be made at the sole discretion of AUB’s local control authority.

**4.0 DEFINITIONS**

**AUB** – means the Athens Utilities Board and its duly authorized employees, agents, and representatives

**Board** – means the Chairman and all Commissioners but does not include any employees

**Local Control Authority** – Superintendent of Water and Wastewater or duly authorized representative

**Main** – designated as the water lines of AUB of all sizes, with service connections excluded, laid in or on the public streets or highways or on right-of-ways whether covered by easement or permission acquired by AUB for the installation of AUB’s water lines on private property

**Service Connection** – Shall mean the tap of the main and that portion of the line extending from the tap of the main to and including the meter and meter installation in those installations where the meter is set at or near the property line on the street, highway, or right-of-way on which the main is located. For meters located elsewhere on private property the service connection is considered to extend from only the tap of the main to the property line, plus the meter and meter installation.

**TDEC** – Tennessee Department of Environment and Conservation

## **5.0 PROCEDURES/POLICY**

### **5.1 Application and Contract for Service**

Each customer or prospective customer desiring original or additional water service shall make a formal application with a duly authorized employee of AUB; shall supply information as may be requested relating to the water consumption, fire protection and the manner in which the service will be utilized; and sign AUB's standard form of application for service, or a general water contract.

### **5.2 Contracts**

AUB's standard form of application for service is the basic contract for all water service. However, when water main extensions are required in order for AUB to provide water service, a certain level of participation may be required or additional nonrefundable financial commitment from the customer(s) for AUB to provide the service. Additionally, large commercial or industrial customers may be requested to execute a General Water Contract, which shall contain provisions and stipulations as may be desirable to protect the interests of AUB and the customer. The use of water by a customer shall be interpreted as binding the customer by the terms of the applicable standard contract and must be signed by the customer receiving service. All basic contracts require the customer to pay a service availability fee for a minimum of three years. If a property is sold before a basic contract's three year time frame has expired, the new property owner will have the option of either signing a basic contract for water service or pay a tap fee when service is requested.

### **5.3 Service Availability Fee Contract**

Prior to construction, AUB may require an applicant for service to sign a contract guaranteeing the payment of service availability fees for such period of time as may be reasonably necessary to support the investment required, but nothing contained herein shall authorize a service availability fee contract that is prohibited by the applicable rate schedule. If property is sold on which a dry tap is located, the new owner has the option to accept a service availability fee contract or pay a tap fee when water service is requested. Where the service is in use, the new owner will be required to pay the service availability fee and the applicable rate based on consumption.

### **5.4 Customer's Obligations**

If for any reason the customer, after signing a contract for service, does not take the service by reason of occupying the premises, or otherwise, he/she shall reimburse AUB for the total expense incurred by reason of AUB's endeavor to furnish said service.

If a customer requests and pays a tap fee where engineering and/or additional fees (by AUB) are required and then requests a refund, AUB will refund the tap/extension fee minus any costs incurred by AUB for the project. Once AUB has committed to a line extension involving multiple customers, extension fees will not be refunded.

## **5.5 Building Permits**

An application for a building permit shall have been received by AUB prior to construction of any facilities to serve the applicant, and the building permit shall have been issued to the prospective customer prior to rendition of any service in those areas where such permits are required by governmental authority.

## **5.6 Land Development Projects**

Preliminary plats must be submitted to AUB to determine availability of service prior to submittal to the Planning Commission for their consideration. Two copies of a preliminary plat furnished by the developer shall accompany an application for water service in subdivisions or land development. Affirmative action, if taken by AUB, will be noted on each copy of the preliminary plat and signed by the AUB Local Control Authority, their designee or General Manager. The developer is responsible for meeting AUB and TDEC specifications for subdivision water line installation. AUB is responsible for meeting TDEC specifications for service to land development projects.

If service capacity is available for the submitted design, a letter of certification will be issued back to the developer from the AUB Local Control Authority. One copy of the plat will be attached to the Local Control Authority letter of certification and be submitted to the Planning Commission having jurisdiction over the land development project, and the other copy will be retained by AUB.

Further action by AUB will be deferred until the preliminary plat has been approved by the Planning Commission and returned to AUB. Pending receipt of such approval, AUB will not authorize, accept, construct, or connect to, any utility installation coming under AUB's jurisdiction in a land development area without prior approval described above.

Approval of the plans for the installation of water/wastewater distribution facilities in land development projects will be certified by a letter from the Local Control Authority to the developer.

## **5.7 Taxes**

All taxes imposed by governmental agencies applicable to water service to customers of AUB shall constitute an additional charge to the amount billed to any customer under any rate schedule, minimum billing, or other charges for water service in accordance with the applicable rate schedule.

## **5.8 Customer Responsibility**

The customer(s) whose name(s) appear on the Application for Service shall be responsible for all charges for water service until a notice is received at the office of AUB ordering the service disconnected. Failure to notify AUB shall not release the customer of any obligation due AUB for any service rendered or made available.

## **5.9 Estimated Bills**

If the employees of AUB are unable for any reason to obtain access to the meter or if AUB has reason to doubt the registration of the meter, or if an error has been discovered in the computation of the bill, AUB reserves the right to render an estimated bill to the customer based on the best information available. If after investigation of the condition, or if subsequent meter readings indicate the estimated bill was incorrect, AUB at its option will either make a compensated adjustment in a later bill, or will adjust the estimated bill to compensate for the error in accordance with TCA.

## **6.0 Service Interruptions**

AUB cannot and does not guarantee either a sufficient supply or an adequate or uniform pressure, and shall not be liable for any damage or loss resulting from an inadequate or interrupted supply, from any pressure variations, or for damages from the resumption of service when such conditions are not due to willful fault or neglect on its part. Damages for which AUB is not liable most commonly involve water heaters and galvanized service lines. There are times when weather, supply problems, construction problems, accidents and other incidents will create situations resulting in service interruptions.



Athens Utilities Board

<b>Division of Water – Policies and Procedures Manual Standard Policies and Procedures</b>	
<b>Policy Number – AUB-01-02</b>	<b>Revision Number: 5</b>
<b>Subject Fire Hydrant Installation and Use</b>	<b>Effective Date: 7/01/13</b>
	<b>Superintendent Approval:</b>
	<b>General Manager Approval:</b>

**1.0 PURPOSE AND SCOPE**

The purpose of this policy is to outline steps and procedures in the installation and use of fire hydrants physically connected to the Athens Utilities Board (AUB) Water Distribution System. This policy applies to all current and potential water accounts serviced by the Athens Utilities Board.

**2.0 REFERENCES**

(1) Athens Utilities Board Division of Water, Policies and Procedures Manual

**3.0 GENERAL**

In the event of a fire, the hydrant nearest the fire may be used without AUB personnel being present. The McMinn County E-911 Communications Center shall notify AUB of any fire within the AUB service area. In the event of a fire, the AUB representative on-site will keep a rough estimate of the amount of water used. If an AUB representative is not on site, the fire department should keep an account of the times the tanker is filled and report this usage to AUB on the next business day. This information will not be used for billing, water used for fire fighting is not billed. This information is used only for water loss accounting purposes.

Any exceptions to this policy will be made at the sole discretion of AUB’s local control authority.

**4.0 DEFINITIONS**

**AUB** – means the Athens Utilities Board and its duly authorized employees, agents, and representatives

**Board** – means the Chairman and all Commissioners but does not include any employees

**Local Control Authority** – Superintendent of Water and Wastewater or duly authorized representative

**Main** – designated as the water lines of AUB of all sizes, with service connections excluded, laid in or on the public streets or highways or on right-of-ways whether covered by easement or permission acquired by AUB for the installation of AUB’s water lines on private property

**Service Connection** – Shall mean the tap of the main and that portion of the line extending from the tap of the main to and including the meter and meter installation in those installations where the meter is set at or near the property line on the street, highway, or right-of-way on which the

main is located. For meters located elsewhere on private property, the service connection is considered to extend from only the tap of the main to the property line, plus the meter and meter installation.

## **5.0 PROCEDURES/POLICY**

### **5.1 Placement of Hydrants**

Regarding the placement of fire hydrants, AUB will place hydrants upon the execution of a contract between a single party and AUB for the placement, installation cost and maintenance of the hydrant installation. All costs for the installation or for moving a hydrant is the responsibility of the entity making the request. Under no circumstances is AUB required to provide fire protection to the customer in question.

Fire hydrants will be placed only where adequate fire flow is available based upon engineering design.

### **5.2 Use of Hydrants**

No one, including emergency personnel, has the authority to use a hydrant for any other purpose than fire fighting without first contacting AUB for approval. Use of hydrants cause water quality and pressure problems, therefore, hydrants shall not be used except in the case of a fire. The water contained in these hydrants is not free and costs AUB to produce; therefore, to be fair to all AUB customers, water used for any purpose other than fighting fires must be charged. The following procedure shall be followed:

1. The homeowner or end user shall provide a receipt for the water or a deposit slip from AUB to the hauler prior to any water being hauled. The fee for this service is included in the Rates/Fees section of the Athens Utilities Board's policies. Water use is based on the meter reading at the hydrant and billed at the current rate for use greater than 5,000 gallons.
2. The hauler shall contact AUB and give the name of the homeowner/end user and when the water will be needed.
3. AUB personnel will verify the payment/deposit and will notify the hauler to proceed to the hydrant located at the North Mouse Creek Wastewater Treatment Plant where there is a meter and connection. If there are extenuating circumstances making it impractical to use this hydrant, AUB personnel will advise which hydrants may be used and will set a hydrant meter prior to use.
4. The hauler can then proceed.
5. This service as described above is provided by AUB during operational hours. If these services are required after hours, an additional \$50.00 charge per call-out is assessed.

Athens Utilities Board

<b>Division of Water – Policies and Procedures Manual Standard Policies and Procedures</b>	
<b>Policy Number – AUB-01-03</b>	<b>Revision Number: 5</b>
<b>Subject Development Extension Policy</b>	<b>Effective Date: 7/01/13</b>
	<b>Superintendent Approval:</b>
	<b>General Manager Approval:</b>

**1.0 PURPOSE AND SCOPE**

The purpose of this policy is to standardize Athens Utilities Board’s (AUB) approach to review and approval of all development design within the AUB service areas, and to standardize the policy regarding cost sharing and agreements for domestic water service. This policy applies to all development that could possibly be serviced by AUB.

**2.0 REFERENCES**

- (1) Athens Municipal Code Title 18 Water and Sewers
- (2) Athens Planning Commission Subdivision Regulations, Section 138 Water Supply System
- (3) Tennessee Department of Environment and Conservation, Chapter 0400-45-01 Public Water Systems

**3.0 GENERAL**

Final review and approval of all aspects of the water supply system will be by the local control authority representing AUB as dictated by References 3-1 and 3-2.

Any exceptions to this policy will be made at the sole discretion of AUB’s local control authority.

The specifications of all material, including but not limited to fire hydrants, and the manner in which all appurtenances are laid shall meet the inspection and approval of the local control authority.

All water construction plans for subdivisions shall include service from the main water line to the property line of each proposed lot in order that each proposed lot, *at the time of construction*, may be served by water without the installation of additional lines. The end of each service shall be properly marked.

The entire cost and expense of installing the required water supply system including the connection to the existing water supply and including but not limited to the cost of pipe, valves, fittings, fire hydrants, trenching, backfilling, and services shall be borne by the developer including the stipulated payment for tapping and metering the system to serve each lot.

The developer is financially responsible for all maintenance on the newly installed system for one year after the system has been completely installed.

## 4.0 DEFINITIONS

**AUB** – means the Athens Utilities Board and its duly authorized employees, agents, and representatives

**Board** – means the Chairman and all Commissioners but does not include any employees

**Local Control Authority** – Superintendent of Water and Wastewater or duly authorized representative

**Main** – designated as the water lines of AUB of all sizes, with service connections excluded, laid in or on the public streets or highways or on right-of-ways whether covered by easement or permission acquired by AUB for the installation of AUB's water lines on private property

**Service Connection** – Shall mean the tap of the main and that portion of the line extending from the tap of the main to and including the meter and meter installation in those installations where the meter is set at or near the property line on the street, highway, or right-of-way on which the main is located. For meters located elsewhere on private property the service connection is considered to extend from only the tap of the main to the property line, plus the meter and meter installation.

## 5.0 POLICY/PROCEDURES

### 5.1 Review and Approval

Developers shall submit plans for the water distribution system installation to the local control authority in a timely manner to allow for proper review and approval.

The specifications of all material, including but not limited to fire hydrants, and the manner in which all appurtenances are laid shall meet the inspection and approval of the local control authority. A technical specification list of materials acceptable for use in the construction of the water distribution system shall be obtained from the local control authority. No exception will be granted for any material not meeting these minimum specifications.

The plans will receive final approval, conditional approval, or be rejected based upon the findings of the technical review. Conditional approval *does not constitute permission to proceed with construction* and indicates that minor design changes must be made in order to receive final approval. Only final approval signified by a signature from the local control authority will signify acceptability of the design for construction purposes.

### 5.2 Installation Inspection

AUB requires inspection of the water distribution system construction. Inspectors will be responsible for the following: ensuring that all construction is installed according to the approved plans; all materials meet specifications set by AUB; making field change requests to the local control authority upon discovery of hidden features or unforeseen circumstances that require changes to the approved plans and recording all changes to the approved plans.

Developers are required to provide a two-week notice prior to the start of construction of the water distribution system in order to allow AUB to assign an inspector for the project.

### **5.3 Development Cost Policy**

Based upon the current regulations in Reference 3-2, the following is Board policy with regard to the cost of development.

The entire cost and expense of installing the required water supply system including the connection to the existing water supply and including but not limited to the cost of pipe, valves, fittings, fire hydrants, trenching, backfilling and services shall be borne by the developer including the stipulated payment for tapping and metering the system to service each lot (if required). Additionally, the developer is financially responsible for all maintenance and repairs on such mains for one year after the system has been completely installed.

If the developer pays multiple tap fees in lieu of installing the water supply system and AUB installs the water supply system, AUB will begin charging the developer for water service on the date the water tap is installed. AUB will charge at least a service availability fee per service regardless of the amount of water used. For further information regarding a service availability fees see Policy AUB-01-01, Obtaining Water Service.

The fees for tapping the system to serve each lot will be applicable when AUB supplies the meter setters, plans review and approval and inspection.

Any exceptions to this policy will be made at the sole discretion of AUB's local control authority.

Upon the completion of construction and final inspection, the developer must submit to AUB a set of 'As-built' plans that reflect any and all changes to the original approved design. The developer must then sign a Transfer Agreement Statement transferring the water distribution system to AUB before water service is provided.



Athens Utilities Board

<b>Division of Water – Policies and Procedures Manual Standard Policies and Procedures</b>	
<b>Policy Number – AUB-01-04</b>	<b>Revision Number: 5</b>
<b>Subject Water Rate Schedule</b>	<b>Effective Date: 7/1/13</b>
	<b>Superintendent Approval:</b>
	<b>General Manager Approval:</b>

**1.0 PURPOSE AND SCOPE**

The purpose of this policy is to outline established water rates of the Athens Utilities Board (AUB) Water Distribution System. This policy applies to all water accounts serviced by the Athens Utilities Board.

**2.0 REFERENCES**

- (1) Athens Utilities Board Division of Water, Policies and Procedures Manual, Schedule of Rates and Fees

**3.0 GENERAL**

Municipal, Residential, Commercial and Industrial single use accounts, serviced by AUB are subject to the water use rates as defined in AUB Schedule of Rates and Fees.

**4.0 DEFINITIONS**

**AUB** – means the Athens Utilities Board and its duly authorized employees, agents, and representatives

**Board** – means the Chairman and all Commissioners but does not include any employees

**Local Control Authority** – Superintendent of Water and Wastewater or duly authorized representative

**Main** – designated as the water lines of AUB of all sizes, with service connections excluded, laid in or on the public streets or highways or on right-of-ways whether covered by easement or permission acquired by AUB for the installation of AUB’s water lines on private property

**Service Connection** – Shall mean the tap of the main and that portion of the line extending from the tap of the main to and including the meter and meter installation in those installations where the meter is set at or near the property line on the street, highway, or right-of-way on which the main is located. For meters located elsewhere on private property the service connection is considered to extend from only the tap of the main to the property line, plus the meter and meter installation.

## **5.0 POLICY/PROCEDURES**

### **5.1 Statement of Rate**

#### Applicability:

WS-22R - To all 5/8 inch residential accounts inside the corporate limits of the City of Athens  
WS-23R - To all 1 inch residential accounts  
WS-24R - To all 1.5 inch residential accounts  
WS-25R - To all 2 inch residential accounts  
WS-26R - To all 5/8 inch residential accounts outside the corporate limits of the City of Athens  
WS-35C – To all 5/8 inch commercial accounts inside the corporate limits of the City of Athens  
WS-36C – To all 1 inch commercial accounts  
WS-37C – To all 1.5 inch commercial accounts  
WS-38C – To all 2 inch commercial accounts  
WS-39C – To all 3 inch commercial accounts  
WS-40C – To all 4 inch commercial accounts  
WS-41C – To all 6 inch commercial accounts  
WS-42C – To all 5/8 inch commercial accounts outside the corporate limits of the City of Athens  
WS-50I – To all 5/8 inch industrial accounts  
WS-51I – To all 1 inch industrial accounts  
WS-52I – To all 2 inch industrial accounts  
WS-53I – To all 3 inch industrial accounts  
WS-54I – To all 4 inch industrial accounts  
WS-55I – To all 6 inch industrial accounts  
WS-56I – To all 1.5 inch industrial accounts  
WS-89W – Wholesale to City of Niota  
WS-90W – Wholesale to City of Riceville

#### Statement of Rate:

A service availability fee will apply to all customers where water service is available. Additionally, customers will be charged based on the amount of water consumed as measured by the customer's water meter.

#### Service Availability Fee:

The net monthly service availability fee shall be determined by the size of the meter serving the account.

Net billing will apply if paid on or before the due date shown on bill rendered. The gross, 5% higher, will apply if paid after the due date shown. Payments received in the mail with a U.S. Postal Service postmark on or before the due date will not be assessed a late charge.

## **5.2 Fire Protection Rates**

Water supplied under this schedule shall be used only for fire extinguishing purposes. No one, emergency personnel included, has the authority to use a hydrant for any other purpose without first contacting AUB for approval.

An annual fire protection fee shall apply to customers having fire protection sprinkler systems and internal system fire hydrants. The annual fee shall vary according to the size of the sprinkler connection.

When it becomes necessary to fill the tank connected to the customer's sprinkler system, the Division must be notified and the seals on the system broken in the presence of AUB's inspector.

Athens Utilities Board

<b>Division of Water – Policies and Procedures Manual Standard Policies and Procedures</b>	
<b>Policy Number – AUB-01-05</b>	<b>Revision Number: 5</b>
<b>Subject Water Adjustment Policy</b>	<b>Effective Date: 7/1/13</b>
	<b>Superintendent Approval:</b>
	<b>General Manager Approval:</b>

**1.0 PURPOSE AND SCOPE**

The purpose of this policy is to outline the water adjustment policy for the Athens Utilities Board (AUB). This policy applies to all water accounts serviced by the Athens Utilities Board.

**2.0 REFERENCES**

None

**3.0 GENERAL**

Residential and industrial customers who purchase water from AUB may request a water service adjustment in accordance with *Section 6.0* of this policy. AUB may at its option make adjustments in water bills where excessive billing is directly traceable to hidden leaks, with the adjustment being made on the basis of AUB absorbing, or writing off, (in dollars and cents, not gallons) no more than one-half (1/2) of the overage directly traceable to such hidden leaks which the customer could not reasonably have been expected to find until a bill for excessive consumption indicated the presence of such leaks. Leaks in interior plumbing, leaking or dripping faucets, leaking or dripping yard hydrants, leaks in commodes, or other loss through the failure of the customer to provide a cut-off water loss due to frozen pipes and water used to keep pipes from freezing are specifically cited as examples of leaks which will not be termed as “hidden leaks” for the purpose of this policy.

**4.0 DEFINITIONS**

**AUB** – means the Athens Utilities Board and its duly authorized employees, agents, and representatives

**Board** – means the Chairman and all Commissioners but does not include any employees

**Local Control Authority** – Superintendent of Water and Wastewater or duly authorized representative

**Main** – designated as the water lines of AUB of all sizes, with service connections excluded, laid in or on the public streets or highways or on right-of-ways whether covered by easement or permission acquired by AUB for the installation of AUB’s water lines on private property

**Service Connection** – Shall mean the tap of the main and that portion of the line extending from the tap of the main to and including the meter and meter installation in those installations where the meter is set at or near the property line on the street, highway, or right-of-way on which the main is located.

For meters located elsewhere on private property the service connection is considered to extend from only the tap of the main to the property line, plus the meter and meter installation.

## 5.0 POLICY/PROCEDURES

No adjustment in billing shall be made where premises are vacated without a notice to discontinue service having been given to AUB.

Customers are advised to use Schedule 40 PVC, Schedule 80 PVC, Copper, or Polyethylene pipe when installing a new water line. AUB cannot force the customer to use the suggested piping materials, but AUB will only give a hidden leak adjustment once if materials other than those specified above are used for a customer's service line..

No more than two adjustments shall be given for hidden leaks, in any 12 consecutive months. These adjustments are given in order for the customer to be aware that their service line is in need of replacement. This is the reasoning for AUB not giving adjustments beyond the 1 for black roll plastic and 2 for other service line types.

There will be no water adjustments because of cold temperatures. An example of a prohibited claim would be leaving water dripping to keep pipes from freezing, or frozen or burst pipes, etc.

Average adjustments shall be given for water consumption when the problem is muddy water, meter malfunctioning, meter setting, etc.

A customer cut-off must be installed at each service. AUB's meters setters are not designed or intended to completely cut-off water service for the customer, they are intended for AUB's use to minimize flow through a meter.

A customer may use the valve in AUB's meter box to minimize or cut water off, however if the valve is broken, the customer will be responsible for all charges associated with its repair.

AUB will make water consumption adjustments for the following scenarios as illustrated in **Figure 1:**

- #1 - Leak on the customer side of meter in an AUB box (average bill adjustment)
- #2 - Leak on the customer service line (hidden leak adjustment, when leak is repaired and certified by AUB personnel)

AUB will not make water consumption adjustment for the following scenarios as illustrated in **Figure 1:**

- #3 - Leak on AUB main (will not register on customer meter)
- #4 - Leak on AUB service connection (will not register on customer meter)
- #5 - Leak on meter connection, AUB side of meter (will not register on customer meter)
- #6 - Leak in customer house piping and fixtures
- #1 - Leak at AUB meter at bottom or top (will not register on customer meter)

**Figure 1. AUB Water Adjustment Customer Locations**

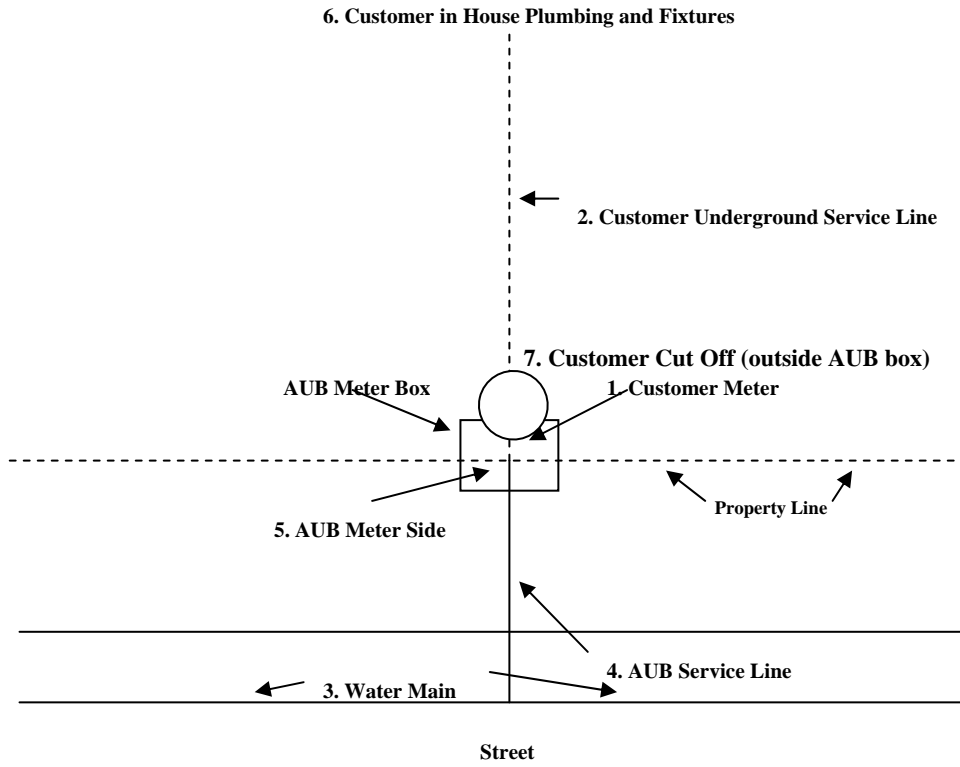

Athens Utilities Board

<b>Division of Water – Policies and Procedures Manual Standard Policies and Procedures</b>	
<b>Policy Number – AUB-01-06</b>	<b>Revision Number: 5</b>
<b>Subject Water Tap Policy and Fee</b>	<b>Effective Date: 07/01/13</b>
	<b>Superintendent Approval:</b>
	<b>General Manager Approval:</b>

**1.0 PURPOSE AND SCOPE**

The purpose of this policy is to outline the Athens Utilities Board (AUB) Water Distribution System water tap policy and fee. This policy applies to all existing and potential water accounts serviced by AUB.

**2.0 REFERENCES**

- (1) Athens Utilities Board, Division of Water, Policies and Procedures Manual
- (2) Athens Utilities Board, Schedule of Rates and Fees

**3.0 GENERAL**

Future connections to the AUB Water Distribution System are required to be coordinated through the local control authority. All requirements listed in this policy and fees are applicable to new water connections.

A customer cut-off must be installed at each serviceAUB’s meters setters are not designed or intended to completely cut-off water service for the customer, they are intended for AUB’s use to minimize flow through a meter.

**4.0 DEFINITIONS**

**AUB** – means the Athens Utilities Board and its duly authorized employees, agents, and representatives

**Board** – means the Chairman and all Commissioners but does not include any employees

**Local Control Authority** – Superintendent of Water and Wastewater or duly authorized representative

**Main** – designated as the water lines of AUB of all sizes, with service connections excluded, laid in or on the public streets or highways or on right-of-ways whether covered by easement or permission acquired by AUB for the installation of AUB’s water lines on private property

**Service Connection** – Shall mean the tap of the main and that portion of the line extending from the tap of the main to and including the meter and meter installation in those installations where the meter is set at or near the property line on the street, highway, or right-of-ways on which the main is located. For meters located elsewhere on private property the service connection is considered to extend from only the tap of the main to the property line, plus the meter and meter installation.



## **5.0 POLICY/PROCEDURES**

### **5.1 Tap Fees**

Before a service connection for residential, commercial, or industrial property will be made by AUB, a tap fee will be paid to AUB. The applicable tap fees will apply as listed in the AUB Schedule of Rates and Fees.

The tap fee includes the material and labor required to make the tap, service connection, meter box, meter and meter installation for ¾-inch taps. Taps greater than ¾-inch include the meter, meter box, meter development and reducer. These fees include an extension of up to a maximum of 50 feet of line from the existing main. Extensions from the main in excess of 50 feet will be installed at cost.

### **5.2 Tap Procedure**

1. Once the customer has met the eligibility requirements for water service, they will be required to pay all necessary fees, complete a Water Service Contract, Closed System Acknowledgement and a Cross-Connection Control Survey. The Cross Connection Survey will determine what requirements will be necessary for the Customer to comply with AUB's Cross Connection Policy. A violation of AUB's Cross-Connection Policy includes having AUB's water supply connected to an auxiliary water supply (well) or anything potentially harmful that could backflow into AUB's water system. If this condition does exist or will exist in the future, AUB requires proper backflow prevention.
2. Once the customer has completed all the necessary steps to sign up for water service, AUB will have a serviceman meet the customer or their representative onsite in order to mutually agree on a location for the water service (meter).
3. When AUB installs the water tap on the Customer's property, the water tap will be locked out until the following items have been installed on the Customer's side of the water tap and an inspection performed by AUB personnel:
  - a. Cut-off device
  - b. Pressure regulator device (if necessary)
  - c. Acceptable service line materials.
4. The Customer shall be responsible for and bear the expense of installing and maintaining the above piping beyond the customer side of the meter.
5. In addition to inspecting the above items, AUB personnel will inspect the Customer's plumbing arrangements for any cross-connection problems/violations. This inspection will be based upon the Cross-Connection Control Survey completed previously by the Customer. Any cross-connection violation will require proper backflow prevention by the Customer.
6. Once the above items have been inspected and approved by AUB personnel, water service will be turned on to the Customer. The cut-off device inside the water service is the property of

AUB.

7.. AUB will begin charging the Customer for water service on the date the water tap is installed by AUB. AUB will charge at least a service availability fee each month regardless of the amount of water used.

### **5.3 Extensions**

Extensions from existing water mains in excess of 50 feet will be made at cost. The estimated cost of the extension and service connection will be paid to AUB in advance of construction and suitable adjustments will be made between the two parties when the actual cost has been determined. As AUB's annual line extension budget allows, AUB will finance a portion of a line extension up to but not exceeding an anticipated ten year payback on AUB's investment. If at any point during the design and construction of an extension AUB determines that the estimated cost of the extension and service connection were too low, AUB may offer a refund and abandon the project or require the potential customer to pay the additional cost.

Water main extensions shall be at least six-inch in diameter into undeveloped areas. Water mains smaller than six-inch in diameter will be laid only in those areas in which natural limitations of whatever description preclude possibility of future land development projects beyond the areas being considered for development.

AUB must approve the size, type and installation of water mains pursuant to this section. Where AUB's long-range plans for the expansion of the water distribution system require mains greater than six-inch in areas to be served under the provisions of this section, the customer desiring water service under the provisions of this section will pay AUB the estimated cost of installing a six-inch main only, and the excess cost for the larger mains will be borne by AUB.

AUB may decline to make extensions where mains are 'overloaded', or limited, in capacity or which might reasonably be expected to become overloaded in the foreseeable future. AUB in all cases shall decline to serve water main extensions for any purpose outside the city limits from overloaded mains of any size located inside the city limits.

Water main extensions require engineering design and approval from agencies outside of AUB. When AUB is expected to design a water line extension, extended delays may occur due to manpower required for engineering and design and for approval from outside agencies. This process is time consuming and delays can often be expected.

### **5.4 Replacing or Relocating Service Connections and/or Meters**

The cost of relocating or replacing existing service connections and/or meters with systems of larger or smaller size shall be the cost as described in AUB Policy, AUB-03, Schedule of Rates and Fees.

### **5.5 Service Connections Made in Advance of Street Improvements**

AUB at its discretion may install service connections in advance of street improvement and street paving projects even though no applications for service have been received from owners of lots adjacent to such street improvement projects. In such cases the tap fee as listed in AUB Schedule of Rates and Fees, will be collected before water service is given at such locations.

### **5.6 Land Development Projects**

All water facilities installed inside any land development project, including fire protection facilities normally provided by a water system, with the cost of fire hydrants included, shall be provided by the land development project owner or promoter at his/her own expense and the facilities required shall include connections, laterals, and valves for fire protection services.

AUB will make the connection between water facilities located on land development projects to the nearest existing main located outside such land development projects, with the cost of the taps, connections, valve installations, etc., to be made at the developer/owner's expense and to be located outside the land development project itself. In no case will AUB be required to extend its facilities, or to increase the capacity of its facilities, to provide water service for a land development project.

AUB at its option may serve installations inside land development projects from water mains of smaller size than those located inside the land development projects. However, AUB will not be required to provide water service in such cases where water service for a land development project could reasonably be expected to lower below reasonable limits the quality or level of service to present customers.

Where water service is required by a land development project promoter or owner in advance of AUB's normal plans for financing and installing additions and improvements required to expand the water system, the improvements required to adequately serve such land development projects shall be made at the expense of the promoter or owner of the land development project, not at the expense of AUB.

Upon completion of such extensions and their approval by AUB, such water mains shall become the property of AUB; and the persons paying the cost of construction of such mains shall execute any written instruments requested by AUB to provide evidence of AUB's title to such mains. In consideration of such mains being transferred to AUB, AUB shall incorporate said mains as an integral part of AUB's water system.

For additional information regarding development projects, see AUB-01-03.

### **5.7 Water Main Design Considerations**

Design will be in accordance with all applicable federal and state regulatory requirements. Detailed design considerations are provided as an addendum to the Water Division Policies and Procedures.

### **5.8 Apartments and Trailer Parks**

AUB will master meter water taps to apartments and trailer parks but will inspect the installation of the service line(s) to the trailer tap or single apartment tap. AUB will disinfect the water line connecting to the service line being installed by the contractor. The contractor or owner will install, flush and disinfect the service line. AUB will sample and analyze a sample from the completed service line prior to serving the line with water. AUB will not assume any responsibility for the service line.

Athens Utilities Board

<b>Division of Water – Policies and Procedures Manual Standard Policies and Procedures</b>	
<b>Policy Number – AUB-01-07</b>	<b>Revision Number: 5</b>
<b>Subject Cross Connections, Auxiliary Intakes, Bypasses and Interconnections</b>	<b>Effective Date: 7/1/13</b>
	<b>Superintendent Approval:</b>
	<b>General Manager Approval:</b>

**1.0 PURPOSE AND SCOPE**

The purpose of this policy is to standardize Athens Utilities Board’s (AUB) approach for review and approval of all development design within the AUB service areas, and to standardize the policy regarding costs for cross connections, auxiliary intakes, bypasses and interconnections to the AUB water system. This policy applies to all existing and potential water accounts serviced by AUB.

**2.0 REFERENCES**

- (1) Athens Municipal Code Title 18 Water and Sewers
- (2) Tennessee Department of Environment and Conservation, Chapter 0400-45-01 Public Water Systems

**3.0 GENERAL**

No person shall cause a cross connection, auxiliary intake, bypass or interconnection to be made or allow one to exist for any purpose unless the construction and operation of same have been approved by AUB in accordance with TDEC and the installation of such cross connection, auxiliary intake, bypass or interconnections under the direct supervision or inspection of AUB. Specification drawings of various AUB connections are available as an addendum to the Water Division Policies and Procedures.

**4.0 DEFINITIONS**

**AUB** – means the Athens Utilities Board and its duly authorized employees, agents, and representatives

**Auxiliary Intake** – Any piping connection or other device whereby water may be secured from a source other than that normally used

**Board** – means the Chairman and all Commissioners but does not include any employees

**Cross Connection** – Any physical connection whereby the public water supply is connected with any other water supply system whether public or private, either inside or outside of any building or buildings, in such manner that a flow of water into the public water supply is possible either through the manipulation of valves or because of ineffective check or back pressure valves or because of any other arrangement

**Interconnection** – Any system of piping or other arrangement whereby the public water supply is connected directly with a sewer, drain, conduit, pool, storage reservoir or other device which

does or may contain sewage or other waste or liquid which would be capable of importing contamination to the public water supply

**Local Control Authority** – Superintendent of Water and Wastewater or duly authorized representative

**Main** – designated as the water lines of AUB of all sizes, with service connections excluded, laid in or on the public streets or highways or on right-of-ways whether covered by easement or permission acquired by AUB for the installation of AUB’s water lines on private property

**Public Water Supply** – The waterworks system furnishing water to the City of Athens, Tennessee for general use and recognized as the Public Water Supply by TDEC

**Service Connection** – Shall mean the tap of the main and that portion of the line extending from the tap of the main to and including the meter and meter installation in those installations where the meter is set at or near the property line on the street, highway, or right-of-way on which the main is located. For meters located elsewhere on private property the service connection is considered to extend from only the tap of the main to the property line, plus the meter and meter installation

**TDEC** – The Tennessee Department of Environment and Conservation

## 5.0 POLICY/PROCEDURES

Any person whose premises are supplied with water from AUB’s water supply and;

- also has on the same premises a separate source of water supply; and/or
- who employs an uncovered or unsanitary storage reservoir or
- where water is stored and is circulated through a piping system,

shall file with AUB a statement of the nonexistence of any unapproved or unauthorized cross connections, auxiliary intakes, bypasses or interconnections. Such statement shall also contain an agreement that no cross connection, auxiliary intake, bypass or interconnection will be permitted upon the premises until the construction and operation of same have received the approval of the AUB, in accordance with TDEC regulations, and the operation and maintenance of same have been placed under the direct supervision of AUB.

Any person who now has cross connections, auxiliary intakes, bypasses or interconnections in violation of this policy shall be allowed a reasonable time within which to comply with the provisions of this policy, unless the cross connection poses an immediate health hazard. In this case service may be immediately discontinued. After a thorough investigation of existing conditions and an appraisal of the time required to complete the work, the amount of time shall be designated by AUB.

AUB will require the use of an approved protective device on the service line serving the premise to assure that any contamination that may originate in the customer’s premises is contained therein. The protective devices shall be a reduced pressure zone type backflow preventer approved by TDEC. The method of installation of backflow protective devices shall be approved by AUB prior to installation and shall comply with the criteria set. Installation will be at the expense of the owner or occupant of the premises. AUB shall have the right to inspect and test the device whenever deemed necessary by the local control authority or his/her designated representative.

Protective devices shall be installed and utilized where the nature of use of the water supplied to a premise by AUB is such that it is deemed:

- Impractical to provide an effective air gap separation,
- That the owner and/or occupant of the premise cannot or is not willing to demonstrate to the local control authority that the water use and protective features of the plumbing pose no threat to the safety or potability of AUB's water supply,
- That the nature and mode of operation within a premise are such that frequent alterations are made to the plumbing,
- There is all likelihood that protective measures may be subverted, altered or disconnected.

Water service shall not be disrupted to test the device without the knowledge of the occupant of the premises. Where the use of water is critical to the continuance of normal operations or protection of equipment, property, or life, duplicate units are recommended to avoid the necessity of discontinuing water service to test or repair the protective device or devices. Where only one unit is installed and the continuance of service is critical, the local control authority shall notify, in writing, the occupant of the premise of plans to discontinue water service to enable testing and/or maintenance of the device.

The local control authority shall see that qualified personnel test all reduced pressure backflow prevention devices on at least an annual basis. The results of these tests are to be evaluated by AUB personnel who shall see that repairs, when needed, are made promptly. Detailed records shall be maintained by AUB on each unit to indicate the date of inspection, conditions found, repairs made, re-testing, etc. The cost of testing and repairs shall be the responsibility of the owner or occupant of the premises.

Whenever any person neglects or refuses to comply with any of the provisions of this policy, AUB shall discontinue the public water supply service at any premises upon which there is found to be a cross connection, auxiliary intake, bypass or interconnection. Service shall not be restored until such cross connection, auxiliary intake, bypass or interconnection has been discontinued.

AUB-01-08  
Forms/Drawings/Specifications  
For Division of Water



A G R E E M E N T  
WATER AND SEWER LINES

THIS AGREEMENT, made and entered into this the \_\_\_\_\_ day of \_\_\_\_\_ 20\_\_, by and between \_\_\_\_\_ hereinafter called the “Developer”, and Athens Utilities Board with offices at 100 New Englewood Road, Athens, Tennessee, hereinafter called the “Board”.

The “Developer” does hereby convey to Athens Utilities Board, Division of Water and Wastewater, Athens, Tennessee, the following amount of pipe, fittings, and appurtenances installed within the property known as \_\_\_\_\_, located on \_\_\_\_\_ in McMinn County, Athens, Tennessee.

WATER LINE: \_\_\_\_\_ (indicate material, DI, PVC, HDPE, etc.)

\_\_\_\_\_ L.F. \_\_\_\_\_ Inch \_\_\_\_\_ Pipe  
\_\_\_\_\_ L.F. \_\_\_\_\_ Inch \_\_\_\_\_ Pipe  
\_\_\_\_\_ Each \_\_\_\_\_ Inch Gate Valves  
\_\_\_\_\_ Each \_\_\_\_\_ Inch Valve W/Box

SEWER LINE: \_\_\_\_\_ (Indicate material, DI, PVC, HDPE, etc.)

\_\_\_\_\_ L.F. \_\_\_\_\_ Inch \_\_\_\_\_ Pipe

THIS AGREEMENT, also includes a 20 foot easement extending 10 feet each side of said lines to the “Board” for the purpose of performing maintenance of said line.

The Athens Utilities Board, Division of Water and Wastewater, hereby agrees to accept said line into its system, and will be responsible for future maintenance of said line.

CUSTOMER

BY: \_\_\_\_\_

DATE: \_\_\_\_\_

WITNESS:

BY: \_\_\_\_\_

DATE: \_\_\_\_\_

ATHENS UTILITIES BOARD

BY: \_\_\_\_\_

DATE: \_\_\_\_\_

WITNESS:

BY: \_\_\_\_\_

DATE: \_\_\_\_\_



**CONVEYANCE AGREEMENT**

This Conveyance Agreement is executed as of the \_\_\_\_ day of \_\_\_\_\_, 20\_\_, by and between \_\_\_\_\_ (“Developer”) and ATHENS UTILITIES BOARD, municipal corporation with offices at 100 New Englewood Road, Athens, TN (“Board”).

**WITNESSETH:**

WHEREAS, Developer does herein convey to Board the following amount of personal properties and/or fixtures, which have been placed and installed within the property, known as \_\_\_\_\_.

NOW, THEREFORE, for and in consideration of the premises set forth herein and other good and valuable considerations, the receipt and sufficiency of which are hereby acknowledged, the parties hereto agree as follows:

1. Developer does hereby convey unto Board all personal property and fixtures set forth on Exhibit A hereto.

2. Developer does hereby convey unto Board an easement extending 10 feet each side of the water line where the water lines are not within existing public right of way for the purpose of performing maintenance of the water line herein conveyed.

3. Board hereby accepts the water lines into its system and does hereby accept the personal properties and fixtures set forth on Exhibit A.

4. Board shall be responsible for any future maintenance of the water line and system and does hereby accept the same as conveyed.

EXECUTED into this \_\_\_\_ day of \_\_\_\_\_, 20\_\_.

ATHENS UTILITIES BOARD

BY: \_\_\_\_\_  
Eric T. Newberry, General Manager

WITNESS: \_\_\_\_\_ Dated this \_\_\_\_ day of \_\_\_\_\_, 20\_\_

DEVELOPER

BY: \_\_\_\_\_  
Its: \_\_\_\_\_

WITNESS: \_\_\_\_\_ Dated this \_\_\_\_ day of \_\_\_\_\_, 20\_\_.

Water Service Warning  
Creating a Closed System

All meter services are installed with a customer cutoff valve and a dual check valve. The customer cutoff valve is for the owner/members use in the event the owner/member wishes to shut off their own water. The dual check valve prevents water from flowing backwards into the water main. This causes owner/members to have a closed system. In the event that an owner/member does not have a pop off valve on his/her water heater(s), the presence of a closed system could cause danger to the customer. Athens Utilities Board is NOT liable for any damages caused at an owner/member's property due to the owner/member's closed system. Customer cutoff valves are the responsibility of the owner/member to maintain and/or replace in the event of malfunction.

ACCT# \_\_\_\_\_

OWNER/MEMBER \_\_\_\_\_

## Cross Connections

A cross connection is an actual or potential link between AUB’s water system and another water source of unknown quality. Once water purchased from AUB passes through your meter, it becomes a “source of unknown quality.” If it is possible that your use of AUB’s water (example: to water livestock, to mix chemicals, to perform dental work, etc.) could impact the water quality in AUB’s system, we must inspect the devices used to decide if a cross connection control device will be required in order to use AUB’s water. If you used a well prior to signing up for water service from AUB, then the well must be completely disconnected from your home plumbing before we will serve you water.

The survey below is necessary to collect information so that we can determine whether it is necessary to conduct a personal visit to your service location to see if a cross connection is likely to exist:

- 1) Do you currently use a well for a water supply? (circle one)      Yes    No

**Proposed Use of AUB’s Water (check all that apply)**

- 2) Residential \_\_\_\_\_ Agricultural \_\_\_\_\_ Commercial \_\_\_\_\_

**Residential Use:**

- 3) Do you plan to install an irrigation system? (circle one)      Yes    No

**Agricultural Use (check all that apply) :**

- 4) Garden \_\_\_\_\_ Crops \_\_\_\_\_ Livestock \_\_\_\_\_

**Commercial Use:**

- 5) Will your use of AUB’s water be only for sanitary purposes (bathroom, sink)?      Yes  
No

- 6) If no, please briefly describe the nature of your business and use of water:

---

---

**Certification:**

I, \_\_\_\_\_, certify that the information provided on this form is true and accurate to the best of my knowledge. I am aware that false statements on this form can result in the termination of my water service. I also understand that any cross connections found

must be protected so as to conform to AUB's cross connection policy and state and federal requirements.

Signed: \_\_\_\_\_ Date: \_\_\_\_\_

# Athens Utilities Board

## Design Data and Information for Water System Calculations

### Reservoir/Tank Information

Tank/Reservoir	Tank 1	Tank 2	Tank 3	Tank 4	Tank 5
Full Elevation (feet)	1122.8	1122.8	1123	1122.8	1123.2
Bottom Elevation (feet)	1083.8	1080.8	1095	1083.8	1090.3
Hydraulic Design Elevation (feet)	1103.3	1101.8	1109	1103.3	1106.45
Capacity (gallons)	2,000,000	1,000,000	1,000,000	2,000,000	567,241

Total Capacity - 6,567,241 gallons

Theoretical Reservoir Design Elevation for System Calculations (Feeds from multiple reservoirs) - 1105 feet

### Modeling and Design Software

Haestad Methods – WaterCAD and Cybernet

### Methodology and Determination of Initial Input Parameters for Model

Perform calculations with software model utilizing Hazen-Williams equation for iterative solution.

Determine initial input parameters by one of the following methods:

- (1) Theoretical - Calculate an equivalent length of pipe to nearest feed tank and model using design tank elevation (50 percent), or if there are multiple feeds use theoretical reservoir design elevation of 1105 feet consistent with Tennessee Department of Environment and Conservation ( TDEC) Design Criteria
- (2) Empirical - Where practicable (primarily single feed extensions), utilize actual main data and design reservoir elevation for existing mains.

- (3) Empirical - Where practicable (mains with fire hydrants in close proximity to extension), utilize hydrant flow data for existing main and calculating a three-point “pump curve” for the system.

### **Validation of Design**

AUB utilizes conservative design assumptions and therefore final adjustments to the construction of the main may be made based upon empirical data (pressure, flow, and reservoir levels) collected in the field. At critical points in the system (potential low flow and pressure points) field data will be collected and compared against reservoir levels to determine actual termination points of mains. This data will be used to ensure that the system meets minimum TDEC requirements for flow and pressure per design criteria.

### **Technical and Material Specifications**

(TDEC) – Division of Water Supply has approved Athens Utilities Board submittal of specifications for materials and drawings for typical installations.

### **Regulatory and Guidance Documents**

TDEC - Division of Water Supply, “Community Public Water Systems Design Criteria”, 1997

TDEC – Division of Water Supply, Chapter 1200-5-1, “Public Water Systems”, August 1999

AWWA Standards as referenced by TDEC or otherwise applicable



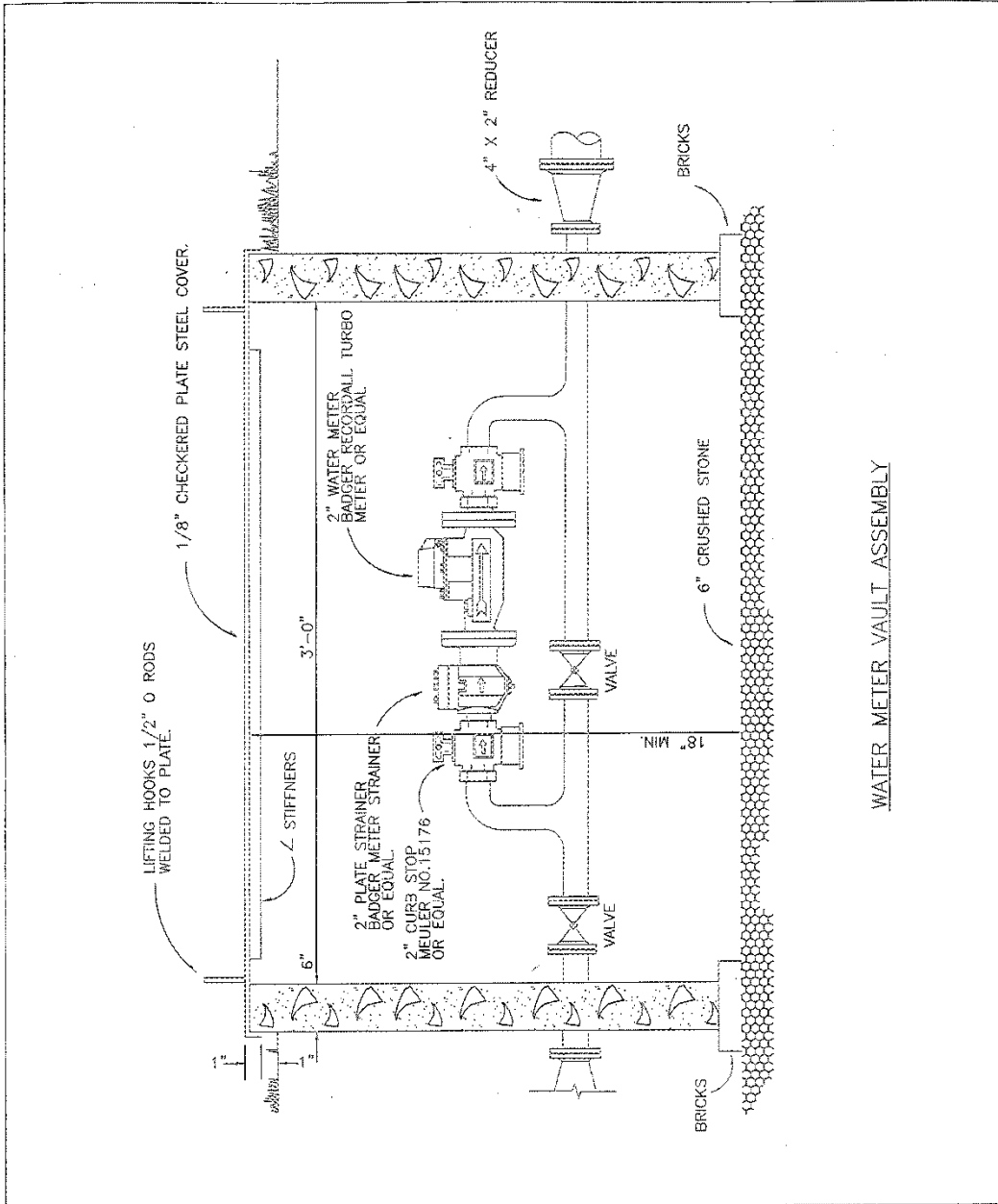

WATER METER VAULT ASSEMBLY

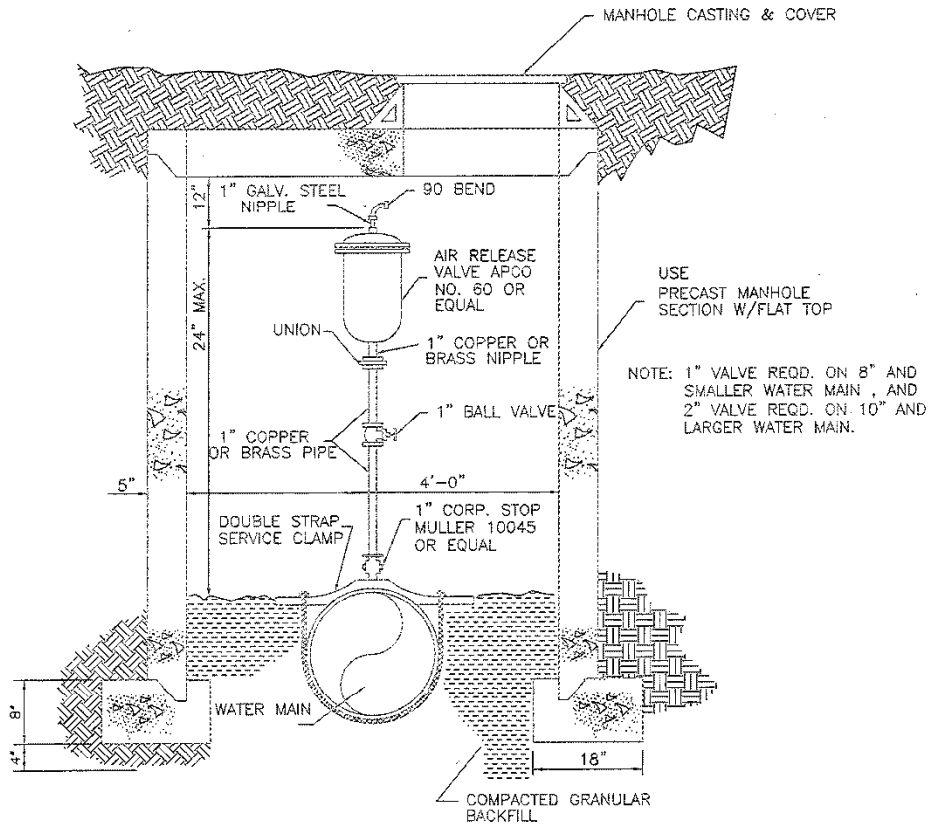

AIR RELEASE VALVE ASSEMBLY

ATHENS UTILITIES BOARD CONSTRUCTION STANDARDS	REVISED:	AIR RELEASE VALVE ASSEMBLY	DRAWING NO.
			AUB-AR-VA 1

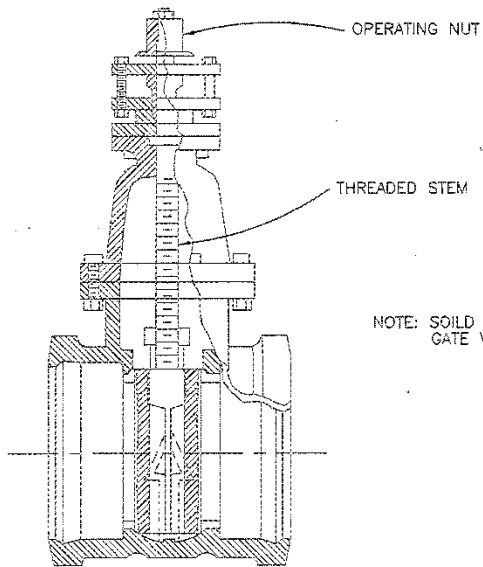

NOTE: SOILD WEDGE RESILIENT SEAT RUBBER GATE VALVE

GATE VALVE SECTION

(CLOSED)  
(M&H OR MUELLER)

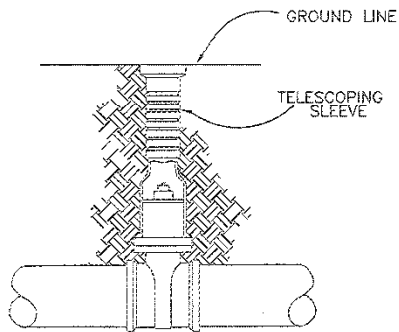

VALVE & BOX INSTALLED



VALVE BOX LID  
CAST IRON, TWO PIECE,  
SLIP TYPE

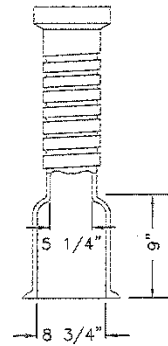

SLIP TYPE  
VALVE BOX

ATHENS UTILITIES BOARD CONSTRUCTION STANDARDS	REVISED:	GATE VALVE & VALVE BOX	DRAWING NO.
			AUB-GV-VB 1

11-1/4° BEND							
SIZE	2"	4"	6"	8"	10"	12"	18"
A	9"	9"	11"	13"	16"	18"	30"
B	9"	9"	11"	13"	16"	18"	30"
C	8"	8"	10"	12"	14"	16"	15"
D	4"	4"	5"	6"	8"	9"	16"

90° BEND							
SIZE	2"	4"	6"	8"	10"	12"	18"
A	16"	16"	26"	33"	40"	50"	70"
B	16"	16"	24"	33"	40"	50"	70"
C	9"	9"	12"	12"	15"	16"	22"
D	8"	8"	12"	16"	20"	25"	24"

45° BEND							
SIZE	2"	4"	6"	8"	10"	12"	18"
A	12"	12"	18"	24"	31"	37"	52"
B	12"	12"	18"	24"	31"	37"	52"
C	8"	8"	10"	12"	14"	16"	14"
D	6"	6"	9"	12"	15"	18"	18"
22-1/2° BEND							
SIZE	2"	4"	6"	8"	10"	12"	18"
A	9"	9"	13"	18"	23"	26"	40"
B	9"	9"	13"	18"	23"	26"	40"
C	8"	8"	10"	12"	14"	16"	15"
D	4"	4"	6"	9"	11"	13"	16"

TEE							
SIZE							
Main	2"-6"	8"-12"	8"-10"	12"	12"	12"	18"
Branch	2"-6"	2"-6"	8"-10"	2"-6"	8"-10"	12"	16"-18"
A	26"	26"	43"	26"	43"	52"	70"
B	26"	26"	43"	26"	43"	52"	70"
C	12"	12"	12"	12"	12"	12"	30"
D	13"	13"	21"	13"	21"	26"	24"
PLUG							
SIZE	2"	4"	6"	8"	10"	12"	18"
A	26"	26"	34"	34"	43"	52"	70"
B	26"	26"	26"	34"	43"	52"	70"
C	12"	12"	12"	12"	12"	12"	30"
D	11"	11"	11"	15"	22"	32"	32"

THRUST BLOCKING DIMENSIONS

ATHENS UTILITIES BOARD CONSTRUCTION STANDARDS	REVISED:	THRUST BLOCKING DIMENSIONS	DRAWING NO.
			AUB-TBD2

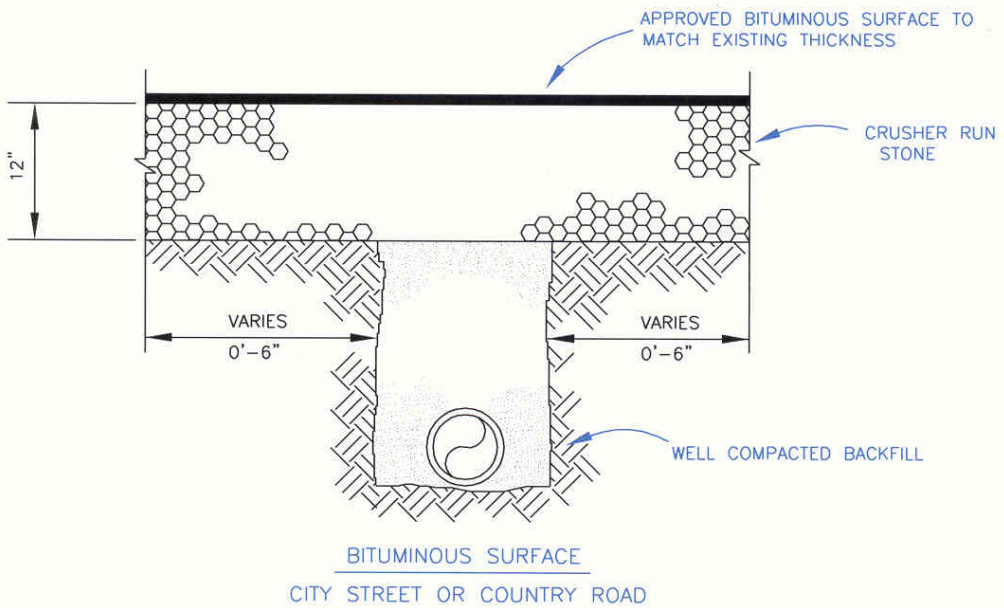
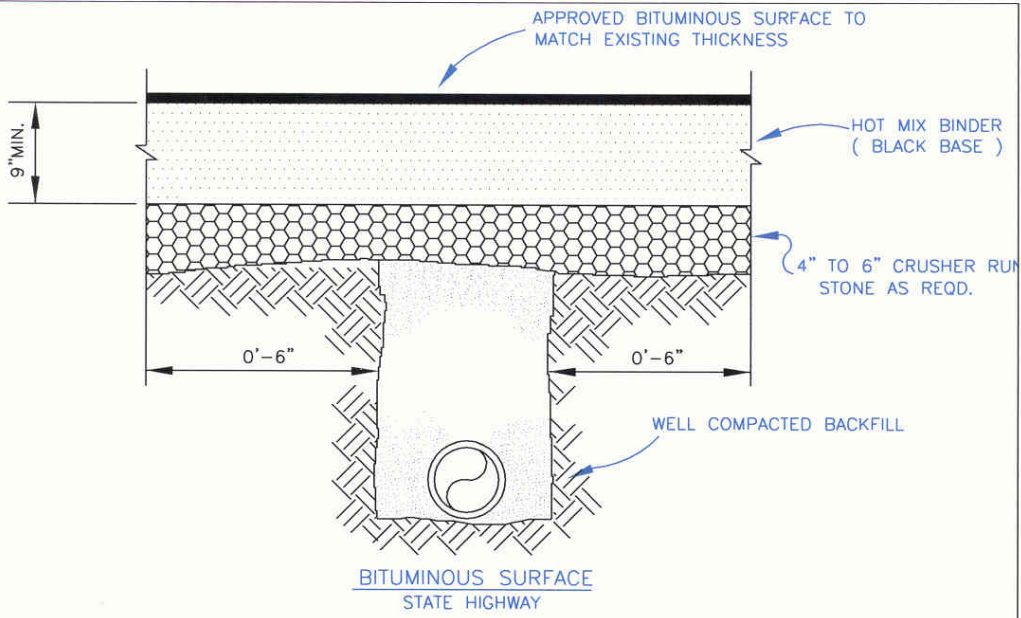

ATHENS UTILITIES BOARD CONSTRUCTION STANDARDS	REVISED:	PAVEMENT REPLACEMENT BACKFILL	DRAWING NO.
			AUB-PR-B 1

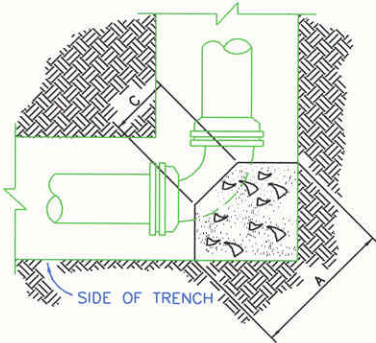

90° BEND

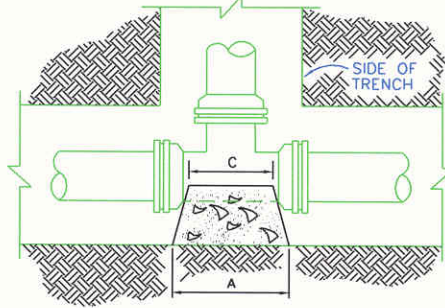

TEE

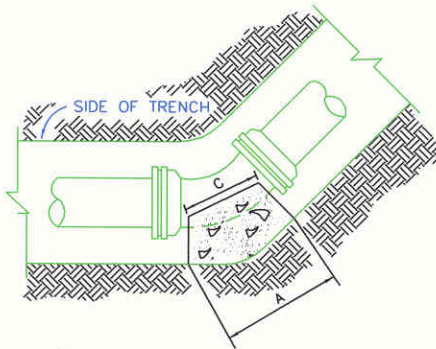

45°- 22 1/2°- 11 1/4° BENDS

NOTE: THRUST BLOCK TO BE  
POURED AGAINST UNDISTURBED  
EARTH.  
SEE TBD2 FOR SIZE

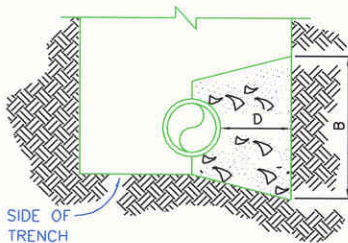

TYPICAL SECTION

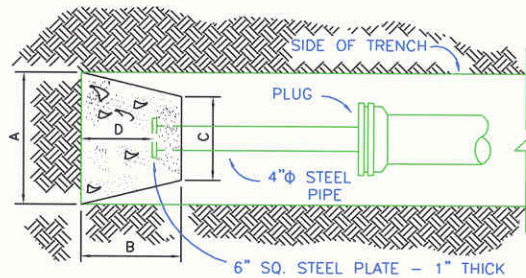

PLUG

ATHENS UTILITIES BOARD CONSTRUCTION STANDARDS	REVISED:	THRUST BLOCKING DETAILS	DRAWING NO.
			AUB-TBD 1

ILLUSTRATION 1  
DESIGN CRITERIA

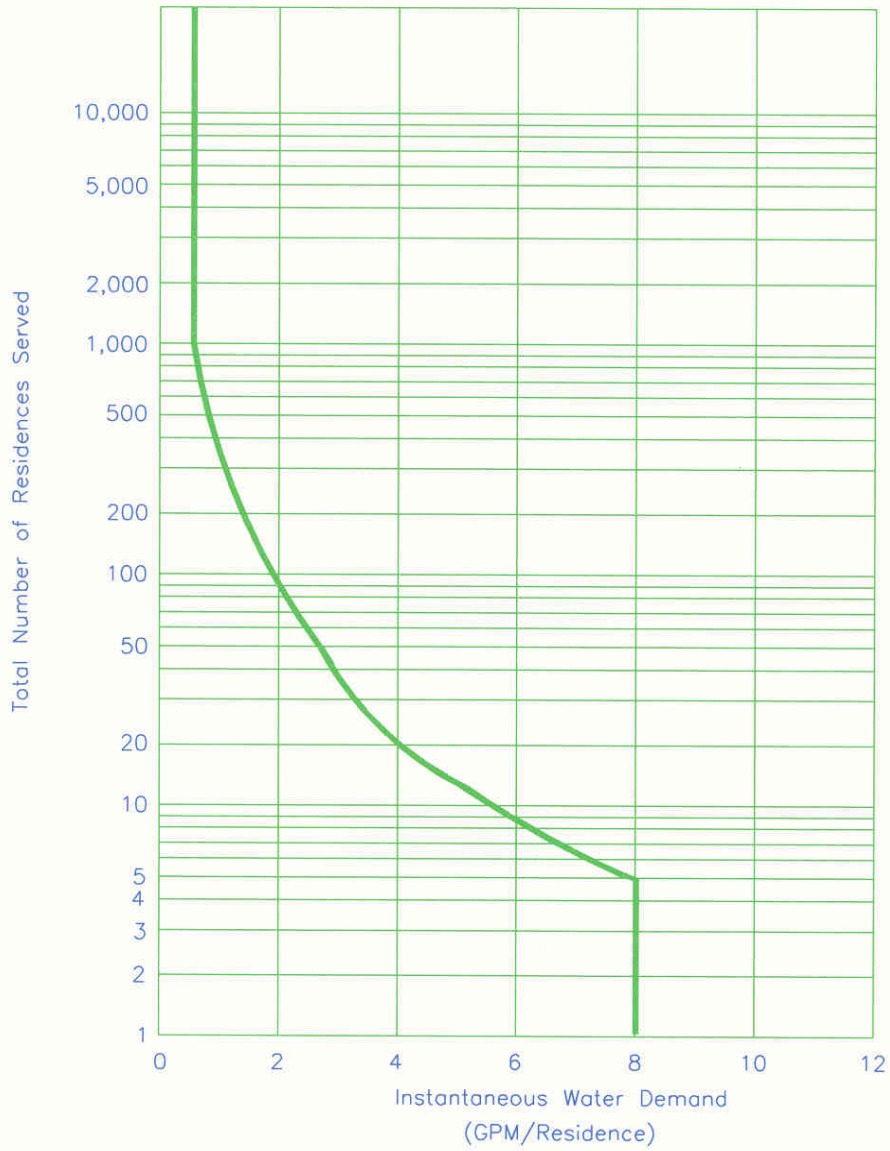

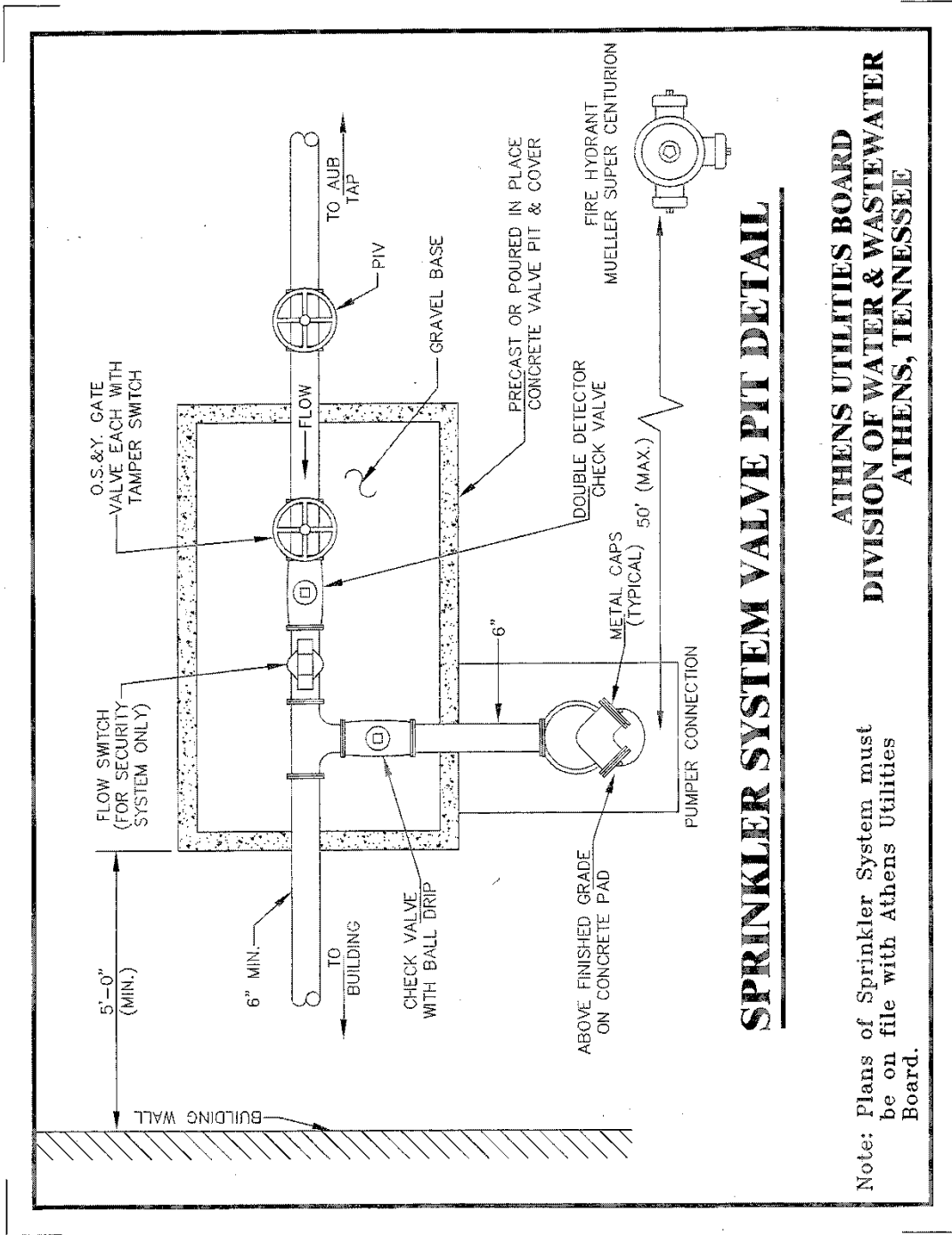

**SPRINKLER SYSTEM VALVE PIT DETAIL**

**ATHENS UTILITIES BOARD  
DIVISION OF WATER & WASTEWATER  
ATHENS, TENNESSEE**

Note: Plans of Sprinkler System must be on file with Athens Utilities Board.



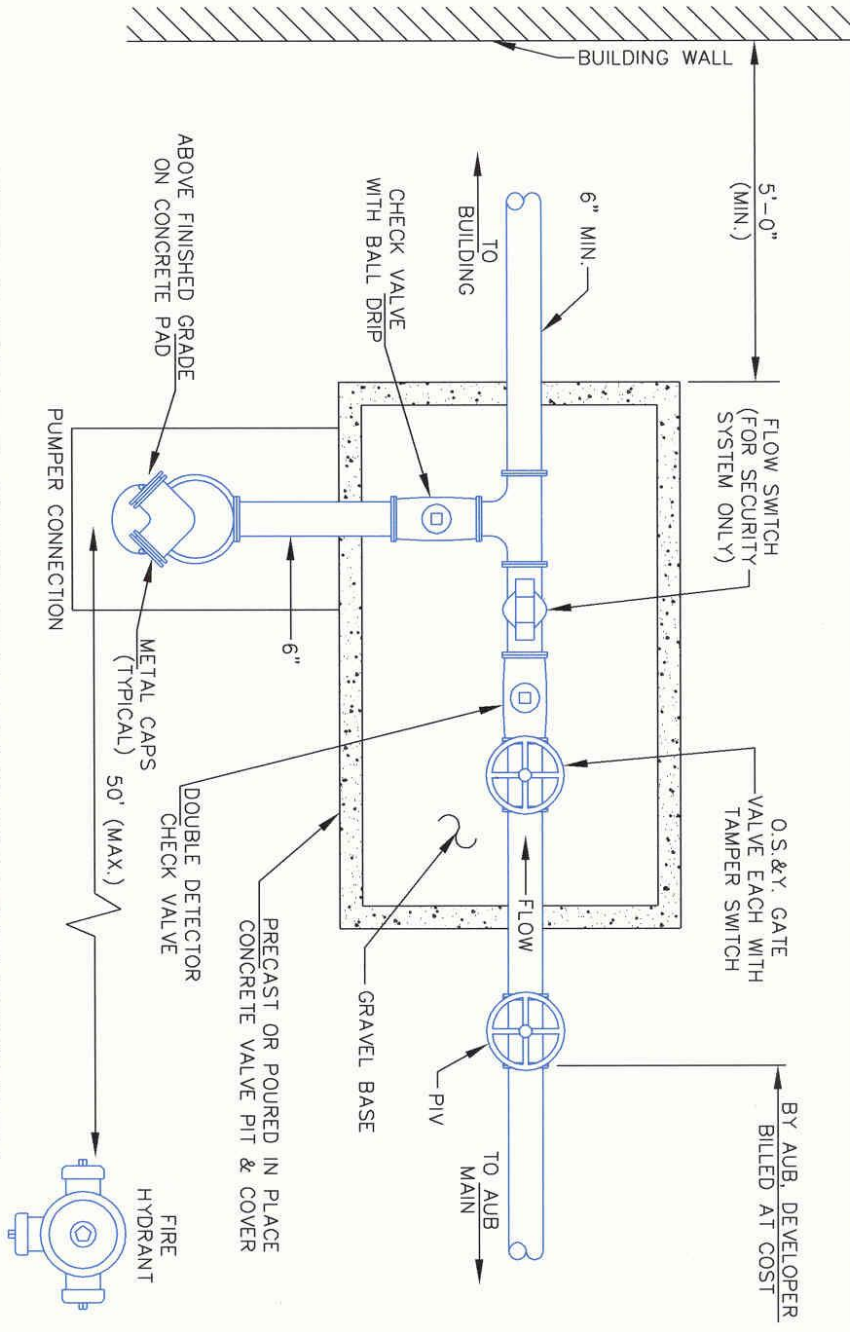

## SPRINKLER SYSTEM VALVE PIT DETAIL

Note: Plans of Sprinkler System must be on file with Athens Utilities Board.

**ATHENS UTILITIES BOARD  
DIVISION OF WATER & WASTEWATER  
ATHENS, TENNESSEE**

***Division of Wastewater – Policies and Procedures Manual***  
***Standard Policies and Procedures***  
***Table of Contents***

AUB-02-01	Prohibitions and Limitations on Wastewater Discharges	224
AUB-02-02	Surcharge Rates for High Strength Wastewater	228
AUB-02-03	Wastewater Use Rates	230
AUB-02-03a	Flat Rate Wastewater Billing	231
AUB-02-04	Wastewater Adjustment Policy	232
AUB-02-04a	Wastewater Asset Responsibility	234
AUB-02-05	Wastewater Tap Policy and Fee	236
AUB-02-06	Grinder Pump Installation	239
AUB-02-07	Collection System Development and Alterations	242
AUB-02-08	Septage Receiving Policy	244
AUB-02-09	Forms/Drawings/Specifications for Division of Wastewater	246

Athens Utilities Board

<b>Division of Wastewater – Policies and Procedures Manual</b>	
<b>Standard Policies and Procedures</b>	
<b>Policy Number – AUB-02-01</b>	<b>Revision Number: 5</b>
<b>Subject</b>	<b>Effective Date: 7/01/13</b>
<b>Prohibitions and Limitations on Wastewater Discharges</b>	<b>Superintendent Approval:</b>
	<b>General Manager Approval:</b>

**1.0 PURPOSE**

The purpose of this policy is to notify all customers of the Athens Utilities Board (AUB) Wastewater Collection System and treatment facilities of prohibited items that cannot be discharged because they may interfere with the wastewater collection and/or treatment capabilities of the Oostanaula Creek and North Mouse Creek Wastewater Treatment Plants.

**2.0 SCOPE**

This policy applies to all residential and industrial users of the AUB Wastewater Collection System and treatment facilities.

**3.0 REFERENCES**

- (1) Athens Municipal Code Title 18 Water and Sewers

**4.0 GENERAL**

Residential and industrial dischargers of wastewater shall ensure that prohibited items listed in **Section 6.0** of this policy are not discharged to the Athens Utilities Board Wastewater Collection System and/or treatment facilities. Those that violate this policy may be subject to fines and penalties, as well as financial responsibilities which ensue for any mitigation actions necessary to correct the problem.

Any exceptions to this policy will be made at the sole discretion of the Board’s local control authority.

**5.0 DEFINITIONS**

**AUB** – the Athens Utilities Board, and its duly authorized employees, agents, and representatives

**Board** – the Chairman and all Commissioners but does not include any employees

**WWTP** – Wastewater Treatment Plant, facilities owned and operated by AUB

**Collection System** – All AUB-owned pipes, manholes and pump stations used to convey wastewater to the WWTP, which are owned and operated by AUB

**Local Control Authority** – Superintendent of Water and Wastewater or duly authorized representative

**Customer** – any person discharging waste to AUB’s Wastewater Collection System and/or wastewater treatment facilities

**6.0 PROCEDURES/POLICY**

**6.1 Prohibited Items Discharged to the Wastewater System**

General Prohibitions. No person or user shall introduce or cause to be introduced into the WWF any pollutant or wastewater which causes Pass Through or Interference. These general prohibitions apply to

all persons and users of the WWF whether or not they are subject to categorical Pretreatment Standards or any other National, State, or local Pretreatment Standards or Requirements. Violations of these general and specific prohibitions or the provisions of this section may result in the issuance of an industrial pretreatment permit, surcharges, discontinuance of water and/or sewer service and other fines and provisions of Section 207. No person or user shall introduce or cause to be introduced into the WWF the following pollutants, substances, or wastewater:

(a) Pollutants which create, or could create a fire or explosive hazard in the WWF, including, but not limited to, wastestreams with a closed-cup flashpoint of less than 140 degrees F (60 degrees C) using the test methods specified in 40 CFR 261.21;

(b) Wastewater having a pH less than 5.0 or more than 10.5, or otherwise causing corrosive structural damage to the WWF or equipment. Prohibited materials include, but are not limited to, acids, sulfides, concentrated chloride and fluoride compounds and substances which will react to form acidic products;

(c) Solid or viscous substances in amounts which will or may cause obstruction of the flow in the WWF or other Interference. Prohibited materials include, but are not limited to, grease, uncomminuted garbage, animal guts or tissues, paunch manure, bones, hair, hides or fleshing, entrails, , feathers, ashes, cinders, sand, spent lime, stone or marble dust, metal, glass, straw, shavings, grass clippings, rags, spent grains, spent hops, waste paper, weeds, plastic, tar, asphalt residues, residues from refining or processing fuel or lubricating oil, and similar substances.;

(d) Pollutants, including oxygen-demanding pollutants (BOD, etc.), released in a discharge at a flow rate and/or pollutant concentration which, either singly or by interaction with other pollutants, will cause Interference with the WWF;

(e) Wastewater having a temperature greater than 150 degrees F (65.5 degrees C), or which will inhibit biological activity in the treatment plant resulting in Interference, but in no case wastewater which causes the temperature at the introduction into the treatment plant to exceed 104 degrees F (40 degrees C);

(f) Petroleum oil, nonbiodegradable cutting oil, or products of mineral oil origin, in amounts that will cause Interference or Pass Through;

(g) Pollutants which result in the presence of toxic gases, vapors, or fumes within the WWF in a quantity that may cause acute worker health and safety problems;

(h) Trucked or hauled pollutants, except at discharge points designated by the control authority in accordance with Section 205 of this ordinance;

(i) Noxious or malodorous liquids, gases, solids, or other wastewater which, either singly or by interaction with other wastes, are sufficient to create a public nuisance or a hazard to life, or to prevent entry into the sewers for maintenance or repair;

(j) Wastewater which imparts color which cannot be removed by the treatment process, such as, but not limited to, dye wastes and vegetable tanning solutions, which consequently imparts color to the treatment plant's effluent;

(k) Wastewater containing any radioactive wastes or isotopes except in compliance with applicable State or Federal regulations and which will or may cause damage or hazards to the sewerage facilities or personnel operating the system;

(l) Storm water, surface water, ground water, artesian well water, roof runoff, subsurface drainage, condensate, deionized water, Noncontact Cooling Water, and unpolluted wastewater, unless specifically authorized by the superintendent;

(n) Wastewater at a flow rate which is excessive relative to the capacity of the treatment works and which could cause a treatment process upset and subsequent loss of treatment efficiency; or wastewater containing such concentrations of pollutants that their introduction into the treatment works over a relatively short time period (i.e. slug discharges) would cause a treatment process upset and subsequent loss of treatment efficiency.

(o) Wastewater causing, alone or in conjunction with other sources, the treatment plant's effluent to fail toxicity test;

(p) Detergents, surface-active agents, or other substances which that might cause excessive foaming in the WWF;

(r) Wastewater causing two successive readings on an explosion hazard meter at the point of discharge into the WWF, or at any point in the WWF, of more than five percent (5%) or any single reading over ten percent (10%) of the Lower Explosive Limit of the meter. Liquids, solids, or gases which by reason of their nature or quantity are, or may be, sufficient to cause fire or explosion or be injurious in any other way to the sewage facilities or operation of the system. Prohibited materials include but are not limited to gasoline, kerosene, naptha, benzene, toluene, xylene, ethers, alcohols, ketones, aldehydes, peroxides, chlorates, perchlorates, bromates, carbides, hydrides and sulfides.

(s) Any wastewater containing toxic pollutants in sufficient quantity, either singly or by interaction with other pollutants, to injure or interfere with any wastewater treatment process, constitute a hazard to humans or animals, create a toxic effect in the receiving waters of the WWF, or to exceed the limitation set forth in a Categorical Pretreatment Standard. A toxic pollutant shall include but not be limited to any pollutant identified pursuant to Section 307(a) of the Act.

(t) Any waste containing microbiological organisms, including filamentous bacteria, in such quantity that will interfere with the normal operation of the WWF.

(u) Any waste that, if otherwise disposed of, would be a hazardous waste under 40 CFR Part 261. Pollutants, substances, or wastewater prohibited by this Section shall not be processed or stored in such a manner that they could be discharged to the WWF.

(v) Any substances which will cause the WWF to violate its NPDES Permit or the receiving water quality standards, or cause any other product of the WWF such as residues, sludges, or scums, to be unsuitable for reclamation and reuse or to interfere with the reclamation process. In no case, shall a substance discharged to the WWF cause the WWF to be in non-compliance with sludge use or disposal criteria, 40 CFR 503, guidelines, or regulations developed under Section 405 of the Act; any criteria, guidelines, or regulations affecting sludge use or disposal developed pursuant to the Solid Waste Disposal Act, the Clean Air Act, the Toxic Substances Control Act, or state criteria applicable to the sludge management

## **6.2 Control of Prohibited Wastes**

If wastewater containing any substance prohibited or limited by the City of Athens Sewer Use Ordinance or this document are discharged or proposed to be discharged into the wastewater collection system, AUB shall take any action necessary to:

1. Prohibit the discharge of such wastewater;
2. Require a discharger to demonstrate that modification will eliminate the discharge of such substances to a degree as to be acceptable to AUB. A compliance schedule may be required;
3. Require pretreatment including storage facilities or flow equalization necessary to reduce or eliminate the objectionable characteristics or substances so that the discharge will not violate these rules and regulations. A compliance schedule may be required;
4. Take such other remedial action as may be deemed to be desirable or necessary to achieve the purpose of this policy.

## **6.3 Line Obstructions**

If collection system obstructions occur on an AUB line or on the main side of the AUB clean-out, then AUB will correct the problem. If the obstruction is on the customer side of the AUB clean-out, the

customer is responsible for all corrective measures, AUB will not inspect or correct the obstruction on the customer's service line.

If a clean-out does not exist and a blockage is found on the service line, then AUB will install an AUB clean-out and determine the location of the blockage. If the obstruction is on the customer side of the newly installed AUB clean-out, then AUB field personnel will inform the customer that they need to contact a plumber or contractor to unstop the service line.

AUB's gravity wastewater collection system includes mains and service lines from the tap to AUB's clean-out which is located in a right-of-way or easement as illustrated *in Figure 1*. AUB's low pressure force main system includes mains, low pressure force mains and grinder pump assemblies. AUB's responsibility begins at the inlet side of the grinder pump.

Athens Utilities Board

<b>Division of Wastewater – Policies and Procedures Manual</b>	
<b>Standard Policies and Procedures</b>	
<b>Policy Number – AUB-02-02</b>	<b>Revision Number: 5</b>
<b>Subject</b> <b>Surcharge Rates for High Strength Wastewater</b>	<b>Effective Date: 7/01/13</b>
	<b>Superintendent Approval:</b>
	<b>General Manager Approval:</b>

**1.0 PURPOSE**

The purpose of this policy is to outline established surcharge rates for wastewaters that contain above normal concentrations of contaminants discharged into the Athens Utilities Board (AUB) Wastewater Collection System.

**2.0 SCOPE**

This policy applies only to industrial users discharging wastewaters to the AUB Wastewater Collection System and treatment facilities.

**3.0 REFERENCES**

- (1) Athens Municipal Code Title 18 Water and Sewers
- (2) EPA, 40 CFR 136

**4.0 GENERAL**

Non-residential discharges that exceed compatible contaminant concentrations or loadings for “domestic wastewater” in *Section 6.1* shall be required to pay additional surcharge rates using the formula in *Section 6.2* in addition to the normal wastewater use fee.

**5.0 DEFINITIONS**

**AUB** – the Athens Utilities Board, and its duly authorized employees, agents, and representatives **Board** – the Chairman and all Commissioners but does not include any employees

**Composite Sample** – a flow proportional sample taken from a waste stream during a specific timeframe (e.g., 24 hours)

**Grab Sample** – a sample taken from a waste stream on a one-time basis with no regard to the flow in the waste stream and without consideration of time

**Local Control Authority** – Superintendent of Water and Wastewater or duly authorized representative

**Representative Sample** – a sample of the actual waste that is being discharged to the AUB Wastewater Collection System and/or treatment facilities

**Customer** – any person discharging waste to AUB’s Wastewater Collection System and/or wastewater treatment facilities

**WWTP** – Wastewater Treatment Plant, facilities owned and operated by AUB

**Industrial User** – any industry discharging waste to the AUB Wastewater Collection System and/or treatment facilities

## 6.0 POLICY/PROCEDURES

A surcharge rate will be assessed for waste containing compatible pollutants in concentrations greater than those for “domestic wastewater.” The surcharge rate shall be based on the average analytical results at a frequency determined by each industrial user’s (IU’s) permit collected at the monitoring manhole during the month. However, a surcharge for holding tank waste shall be based on a representative grab sample. Samples shall be collected and analyzed by either department personnel at the WWTP, by an authorized independent laboratory or by the permitted user when required by the local control authority. Sample collection and analysis shall be in accordance with 40 CFR Part 136 as amended.

### 6.1 Surcharge Limits

The following table lists wastewater discharge limitations for specific contaminants. Wastewaters in excess of the table limits or authorized Industrial User (IU) permits are subject to AUB surcharge rates.

Contaminant	Wastewater System Limit
BOD	300 mg/l
Suspended Solids	300 mg/l
Total Kjeldahl Nitrogen	40 mg/l
Fats, Oils and Grease (FOG)	100 mg/l
Phosphorus	10 mg/l
Nitrogen	30 mg/l

### 6.2 Surcharge Rate Calculation

The following formula shall be used to determine the amount of surcharge unless defined otherwise in an industrial user’s permit:

$$\text{SURCHARGE RATE} = S_{\text{BOD}} + S_{\text{TSS}} + S_{\text{TKN}} + S_{\text{FOG}} + S_{\text{P}} + S_{\text{N}}$$

Where,

$S_{\text{BOD}}$	= surcharge for BOD = (Discharge Value – 300 mg/l) * 8.34 / 1,000 * Flow to Collection System (in thousands of gallons) * Number of days in that month
$S_{\text{TSS}}$	= surcharge for Suspended Solids = (Discharge Value – 300 mg/l) * 8.34 / 1,000 * Flow to Wastewater (in thousands of gallons) * Number of days in that month
$S_{\text{TKN}}$	= surcharge for Total Kjeldahl Nitrogen = (Discharge Value – 40 mg/l) * 8.34 / 1,000 * Flow to Wastewater (in thousands of gallons) * Number of days in that month
$S_{\text{FOG}}$	= surcharge for Fats, Oils and Grease = (Discharge Value – 100 mg/l) * 8.34 / 1,000 * Flow to Wastewater (in thousands of gallons) * Number of days in that month
$S_{\text{P}}$	= surcharge for Total Phosphorus = (Discharge Value – 10 mg/l) * 8.34 / 1,000 * Flow to Wastewater (in thousands of gallons) * Number of days in that month
$S_{\text{N}}$	= surcharge for Total Nitrogen = (Discharge Value – 30 mg/l) * 8.34 / 1,000 * Flow to Wastewater (in thousands of gallons) * Number of days in that month

The surcharge shall be added to the customer’s monthly bill.

\*”Discharge Values” will be actual daily values when data is available and monthly average values otherwise.



Athens Utilities Board

<b>Division of Wastewater – Policies and Procedures Manual Standard Policies and Procedures</b>	
<b>Policy Number – AUB-02-03</b>	<b>Revision Number: 5</b>
<b>Subject Wastewater Use Rates</b>	<b>Effective Date: 7/01/13</b>
	<b>Superintendent Approval:</b>
	<b>General Manager Approval:</b>

### 1.0 PURPOSE AND SCOPE

The purpose of this policy is to outline established Athens Utilities Board (AUB) Wastewater Collection System use rates. This policy applies to all wastewater accounts serviced by the AUB. Surcharge rates are applicable only to non-residential users.

### 2.0 REFERENCES

- (1) Athens Municipal Code Title 18 Water and Sewers

### 3.0 GENERAL

All customers are subject to the wastewater rates as defined in the AUB Schedule of Rates and Fees.

### 4.0 DEFINITIONS

**AUB** – the Athens Utilities Board, and its duly authorized employees, agents, and representatives **Board** – the Chairman and all Commissioners but does not include any employees

**Local Control Authority** – Superintendent of Water and Wastewater or duly authorized representative  
**Customer** – any person discharging wastes to AUB’s Wastewater Collection System and wastewater treatment facilities

**WWTP** – Wastewater Treatment Plant, facilities owned and operated by AUB

### 5.0 POLICY/PROCEDURES

The wastewater use rates will apply to all customers unless a special billing agreement applies. The wastewater rates will also apply to all water customers within the corporate city limits of the City of Athens where a wastewater collection system is available. The monthly service availability charge will apply to all customers including those with special billing agreements. Users (excluding permitted users) are billed according to water consumption as measured by the customer’s water meter.

Net billing will apply if paid on or before due date shown on the bill rendered. The gross 5% higher rate will apply if paid after the due date shown.

Non-residential customers contributing wastewater in excess of domestic strength shall be billed according to AUB Policy – Surcharge Rates for High Strength Wastewater (AUB-02-02).

<b>Division of Wastewater – Policies and Procedures Manual</b>	
<b>Standard Policies and Procedures</b>	
<b>Policy Number – AUB-02-03a</b>	<b>Revision Number: 0</b>
<b>Subject</b> <b>Flat Rate Wastewater Billing</b>	<b>Effective Date: 1/1/2016</b>
	<b>Superintendent Approval:</b>
	<b>General Manager Approval:</b>

**1.0 PURPOSE**

The purpose of this policy is to outline the policies and procedures of Athens Utilities Board (AUB) for billing a wastewater account a flat monthly fee.

**2.0 SCOPE**

This policy applies to all wastewater accounts serviced by AUB.

**3.0 REFERENCES**

(1) Athens Municipal Code Title 18 Water and Sewers

**4.0 GENERAL**

AUB’s residential wastewater billing is calculated based on potable water consumption, as measured by AUB’s water meters. There may be occasions where wastewater service is provided by AUB in areas where either, (1) a customer’s potable water is provided by a private water source such as a well or spring, or (2) water service is provided by another entity.

This policy outlines the procedure AUB will use when an AUB meter reading is not available to calculate a wastewater bill.

**5.0 DEFINITIONS**

**AUB** – the Athens Utilities Board, and its duly authorized employees, agents, and representatives

**Board** – the Chairman and all Commissioners but does not include any employees

**Local Control Authority** – Superintendent of Water and Wastewater or duly authorized representative

**Customer** – any person discharging wastes to AUB’s Wastewater Collection System and wastewater treatment facilities

**6.0 POLICY/PROCEDURES**

Where AUB has a residential wastewater customer whose monthly bill cannot be calculated using the reading from an AUB water meter, the bill will be based on the current user availability fee plus the current rate for 4,000 gallons of discharge and levied as a ‘flat rate’ and contained in AUB’s most current schedule of rates and fees.

If potable water is provided by a neighboring water authority’s meter and the reading can be readily attained by AUB, then the meter reading may be used instead to calculate the customer’s wastewater bill.

Athens Utilities Board

<b>Division of Wastewater – Policies and Procedures Manual</b>	
<b>Standard Policies and Procedures</b>	
<b>Policy Number – AUB-02-04</b>	<b>Revision Number: 5</b>
<b>Subject</b> <b>Wastewater Adjustment Policy</b>	<b>Effective Date: 7/01/13</b>
	<b>Superintendent Approval:</b>
	<b>General Manager Approval:</b>

**1.0 PURPOSE AND SCOPE**

The purpose of this policy is to outline the wastewater adjustment policy for Athens Utilities Board (AUB). This policy applies to all wastewater accounts serviced by AUB.

**2.0 REFERENCES**

AUB Wastewater Division Policy AUB-02-03, Wastewater Use Rates

**3.0 GENERAL**

The local control authority or their designee may make adjustments in wastewater bills where excessive billing is directly traceable to hidden water leaks. The adjustment will be based on a six-month average bill (or length of service if less than six months). AUB will absorb the overage relative to hidden water leaks. Adjustments will apply to leaks the customer could not reasonably have been expected to find until billed. Adjustments will be limited to two billing cycles. Water leaks in interior plumbing, leaking or dripping faucets, leaking or dripping yard hydrants, leaks in commodes, or other water loss due to frozen pipes and water used to keep pipes from freezing are specifically cited as examples of leaks which are not “hidden leaks” for the purpose of this policy.

**4.0 DEFINITIONS**

**AUB** – the Athens Utilities Board, and its duly authorized employees, agents, and representatives **Board** – the Chairman and all Commissioners but does not include any employees

**Local Control Authority** – Superintendent of Water and Wastewater or duly authorized representative  
**Customer** – any person discharging waste to AUB’s Wastewater Collection System and wastewater treatment facilities

**WWTP** – Wastewater Treatment Plant, facilities owned and operated by AUB

## **5.0 POLICY/PROCEDURES**

No adjustment in billing shall be made where premises are vacated without a notice to discontinue service having been given to AUB.

One (1) adjustment per year for a swimming pool will be allowed. When a new pool is installed, AUB will send a representative from the wastewater collection system to verify that no drains are connected to the wastewater system. Swimming pool adjustments are approved by the local control authority and are made at the customer's request.

One (1) two month adjustment per year for summertime irrigation will be allowed for grinder pump customers. This adjustment will be for the months of July and August of each year and will be based on a six month average bill. Grinder pump adjustments are approved by the local control authority and are made at the customer's request.

AUB does not process wastewater adjustments for the following:

- Leaking commodes
- Watering yards
- Gardens
- Fountains
- Waterbeds
- Hot tubs
- Water gardens
- Washing houses, cars, etc.
- Faucets left on either by the customer or vandals.

No more than two adjustments for hidden leaks will be given in any 12 consecutive months.

## Athens Utilities Board

<b>Division of Wastewater – Policies and Procedures Manual</b>	
<b>Standard Policies and Procedures</b>	
<b>Policy Number – AUB-02-04a</b>	<b>Revision Number: 5</b>
<b>Subject</b> <b>Wastewater Asset Responsibility</b>	<b>Effective Date: 7/01/13</b>
	<b>Superintendent Approval:</b>
	<b>General Manager Approval:</b>

### 1.0 PURPOSE AND SCOPE

The purpose of this policy is to outline the responsibilities of the Athens Utilities Board (AUB) in regards to line obstructions and maintenance. This policy applies to all wastewater accounts serviced by AUB.

### 2.0 REFERENCES

AUB Wastewater Division Policy AUB-02-01, Prohibitions and Limitations on Wastewater Discharges  
AUB Wastewater Division Policy AUB-02-05, Wastewater Tap Policy and Fee

### 3.0 GENERAL

AUB operates an ongoing maintenance and rehabilitation program with the directive to eliminate inflow and infiltration (I/I) and to minimize collection system obstructions and stop-ups.

AUB will maintain the wastewater collection system and will correct any obstructions within the AUB system. Customers shall be responsible for any maintenance and/or obstruction in their service line.

### 4.0 DEFINITIONS

**AUB** – the Athens Utilities Board, and its duly authorized employees, agents, and representatives  
**Board** – the Chairman and all Commissioners but does not include any employees

**Local Control Authority** – Superintendent of Water and Wastewater or duly authorized representative  
**Customer** – any person discharging waste to AUB’s Wastewater Collection System and wastewater treatment facilities

**WWTP** – Wastewater Treatment Plant, facilities owned and operated by AUB

## **5.0 POLICY/PROCEDURES**

AUB's gravity wastewater collection system includes mains and service lines from the tap to AUB's clean-out which is located in a right-of-way or easement as illustrated in *Figure 1*. AUB's low pressure force main system includes mains, low pressure force mains and grinder pump assemblies. AUB's responsibility begins at the inlet side of the grinder pump.

If collection system obstructions occur on an AUB line or on the main side of the AUB clean-out, then AUB will correct the problem. If the obstruction is on the customer side of the AUB clean-out, the customer is responsible for all corrective measures, AUB will not inspect or correct the obstruction on the customer's service line.

If a clean-out does not exist and a blockage is found on the service line, then AUB will install an AUB clean-out and determine the location of the blockage. If the obstruction is on the customer side of the newly installed AUB clean-out, then AUB field personnel will inform the customer that they need to contact a plumber or contractor to unstop the service line.

Athens Utilities Board

<b>Division of Wastewater – Policies and Procedures Manual</b>	
<b>Standard Policies and Procedures</b>	
<b>Policy Number – AUB-02-05</b>	<b>Revision Number: 5</b>
<b>Subject</b> <b>Wastewater Tap Policy and Fee</b>	<b>Effective Date: 7/01/13</b>
	<b>Superintendent Approval:</b>
	<b>General Manager Approval:</b>

**1.0 PURPOSE AND SCOPE**

The purpose of this policy is to outline the wastewater tap policy and the associated Athens Utilities Board (AUB) fee for the tap. This policy applies to all existing and future wastewater accounts serviced by AUB.

**2.0 REFERENCES - NONE**

**3.0 GENERAL**

Future connections to the wastewater collection system are required to be coordinated through the local control authority for AUB. All policy requirements listed in the AUB Schedule of Rates and Fees are applicable to new AUB Wastewater Collection System connections.

If a request for a tap is made for an existing residence within the AUB collection system, AUB will waive the wastewater tap fee (excluding the cost of the grinder pump and assembly for low pressure force main installations) provided the current resident has lived at the address in question for at least two (2) years and has paid a wastewater bill.

Wastewater tap fees are divided into three categories - taps 6” or smaller, taps greater than 6” and single dwelling grinder pump installations.

Grinder pump installations include an E-one pump assembly, required materials and labor. Grinder pump installations for multiple family dwellings or commercial use shall be at cost. A main line extension will require a fee in addition to the tap fee.

Wastewater taps will only be made on the customer’s property unless a properly recorded easement is submitted.

Customers shall not share customer service lines unless approved by the local control authority.

**DEFINITIONS**

**AUB** – the Athens Utilities Board, and its duly authorized employees, agents, and representatives **Board** – the Chairman and all Commissioners but does not include any employees

**Extension** – piping required to connect a potential customer from their property line to the existing collection system in excess of 50 feet, up to and including any additional user connections for a period of two years from the completion of the extension.

**Local Control Authority** – Superintendent of Water and Wastewater or duly authorized representative

**Customer** – any person discharging waste to AUB’s Wastewater Collection System and wastewater treatment facilities

**WWTP** – Wastewater Treatment Plant, facilities owned and operated by AUB

## **4.0 POLICY/PROCEDURES**

### **5.1 Tap Fees**

Before a service connection for residential, commercial, or industrial property will be made by AUB, a tap fee will be paid to AUB. The applicable tap fees will apply as listed in the AUB Schedule of Rates and Fees.

The tap fee includes the material and labor required to make the tap, service connection and clean-out.

If a customer requests and pays a tap fee where engineering and/or additional fees (by AUB) are required and then requests a refund, AUB will refund the tap/extension fee minus any costs incurred by AUB for the project.

### **5.2 Extensions**

Gravity extensions from existing water mains in excess of 25 feet will be made at cost. In the event that multiple customers in an area have applied for service, the sum of their allocated extension (25 feet each) will be subtracted from the total cost of the project. The estimated cost of the extension and service connection will be paid to AUB in advance of construction and suitable adjustments will be made between the two parties when the actual cost has been determined. As AUB's annual line extension budget allows, AUB will finance a portion of a line extension up to but not exceeding an anticipated twenty year payback on AUB's investment.

Gravity wastewater collection system main extensions shall be at least eight-inch in diameter into undeveloped areas.

AUB must approve the size, type and installation of wastewater mains pursuant to this section. Where AUB's long-range plans for the expansion of the wastewater collection system require gravity mains greater than eight-inch in areas to be served under the provisions of this section, the customer desiring wastewater service under the provisions of this section will pay AUB the estimated cost of installing an eight-inch main only, and the excess cost for the larger mains will be borne by AUB. Low pressure force main extensions will follow this same procedure with the minimum size main consisting of two inches in diameter. For additional information regarding low pressure force mains, see AUB-02-06.

AUB may decline to make extensions where mains are 'overloaded', or limited, in capacity or which might reasonably be expected to become overloaded in the foreseeable future. AUB in all cases shall decline to serve wastewater collection system extensions for any purpose outside the city limits from overloaded mains of any size located inside the city limits.

### **5.3 Replacing or Relocating Service Connections and/or Meters**

The cost of relocating or replacing existing service connections with systems of larger or smaller size shall be the cost as described in AUB Policy, AUB-03, Schedule of Rates and Fees.

### **5.4 Service Connections Made in Advance of Street Improvements**

AUB at its discretion may install service connections in advance of street improvement and street paving projects even though no applications for service have been received from owners of lots adjacent to such



street improvement projects. In such cases the tap fee as listed in AUB Schedule of Rates and Fees, will be collected before water/wastewater service is given at such locations.

## **5.5 Land Development Projects**

All wastewater facilities installed inside any land development project, shall be provided by the land development project owner or promoter at his/her own expense and the facilities required shall include connections, laterals, manholes, lift stations, clean-outs and valves. All plans will be subject to review and approval as outlined in AUB-02-07, Section 6.1.

AUB will make the connection between wastewater facilities located on land development projects to the nearest existing manhole located outside such land development projects, with the cost of the taps, connections, manholes, lift stations, valve installations, etc., to be made at the developer/owner's expense and to be located outside the land development project itself. In no case will AUB be required to extend its facilities, or to increase the capacity of its facilities, to provide wastewater service for a land development project.

Where wastewater service is required by a land development project promoter or owner in advance of AUB's normal plans for financing and installing additions and improvements required to expand the wastewater system, the improvements required to adequately serve such land development projects shall be made at the expense of the promoter or owner of the land development project, not at the expense of AUB.

Upon completion of such extensions and their approval by AUB, such wastewater mains shall become the property of AUB; and the persons paying the cost of construction of such mains shall execute any written instruments requested by AUB to provide evidence of AUB's title to such mains and is financially responsible for all maintenance and repairs on such mains for one year. In consideration of such mains being transferred to AUB, AUB shall incorporate said mains as an integral part of AUB's wastewater collection system.

For additional information regarding development projects, see AUB-02-07.

## **5.6 Wastewater Collection System Main Design Considerations**

Design will be in accordance with all applicable federal and state regulatory requirements. Detailed design considerations are provided as an addendum to the Wastewater Division Policies and Procedures.

## **5.7 Apartments and Trailer Parks**

AUB will master meter water taps to apartments and trailer parks for the purposes of wastewater billing but will inspect the installation of the wastewater lateral line(s) to the trailer tap or single apartment tap. The contractor or owner will install the service line. AUB will assume no responsibility for the service line.

Athens Utilities Board

<b>Division of Wastewater – Policies and Procedures Manual</b>	
<b>Standard Policies and Procedures</b>	
<b>Policy Number – AUB-02-06</b>	<b>Revision Number: 5</b>
<b>Subject Grinder Pump Installation</b>	<b>Effective Date: 7/1/13</b>
	<b>Superintendent Approval:</b>
	<b>General Manager Approval:</b>

**1.0 PURPOSE AND SCOPE**

The purpose of this policy is to outline the installation requirements of single dwelling grinder pump pressure systems. This policy applies to all existing and future wastewater accounts serviced by Athens Utilities Board (AUB).

**2.0 REFERENCES**

AUB Wastewater Division Policy AUB-02-05, Wastewater Tap Policy and Fee; AUB Wastewater Division Policy AUB-02-01, Prohibitions and Limitations on Wastewater Discharges; Title 18, Athens Municipal Code, Water and Sewers.

**3.0 GENERAL**

**MULTIPLE**

The local control authority shall approve any grinder pump pressure wastewater system prior to design and installation of the system. Multiple grinder pump manufacturers are acceptable; however, AUB will only stock E-One equipment for repair and maintenance purposes, allowing expedient service. Equipment from other manufacturers will be ordered as needed and service will be delayed based on delivery schedules.

Grinder pump assemblies shall be purchased as a unit. The grinder pump unit shall include a basin, a grinder pump, an inlet, a discharge assembly and a UL-approved control panel. The system shall also include a manufacturer’s installation guide and operation and maintenance manuals.

The grinder pump station should be installed as close as possible to the facility to be served yet allow adequate space for access and maintenance. The grinder pump station and associated controls and valves must be accessible to AUB personnel at all times. A site that minimizes the chances of physical damage to the grinder pump station should also be considered when selecting the location. Prior to installation of any unit, the customer or the customer’s contractor (in new developments) shall coordinate all installation activities and schedules with AUB. All grinder pump installations must include a cleanout located between the grinder pump and the building being served, as shown in AUB’s grinder pump installation specifications.

**4.0 DEFINITIONS**

**AUB** – the Athens Utilities Board, and its duly authorized employees, agents, and representatives **Board** – the Chairman and all Commissioners but does not include any employees

**Local Control Authority** – Superintendent of Water and Wastewater or duly authorized representative

**Customer** – any person discharging waste to AUB’s Wastewater Collection System and wastewater treatment facilities

## **5.0 POLICY/PROCEDURES**

### **5.1 Grinder Pump System Installation**

AUB will install the grinder pump assembly, the piping from the grinder pump to the wastewater collection main and a control cabinet, including wiring from the control cabinet to the grinder pump. The customer shall furnish and install the piping from the house gravity wastewater to the grinder pump basin assembly. A cleanout must be installed between the grinder pump and the building being served. The customer must provide electric service to the control panel. The customer may choose to install the grinder pump assembly themselves. All installations will be made in accordance with the current AUB specifications.

The 240-volt, 30-amp electrical service to the grinder pump station must be installed in accordance with all applicable codes. A lockable electrical disconnect switch must be installed before the control panel. The electrical disconnect switch is to be mounted within sight of the grinder pump station. All installations must be in accordance with current AUB specifications and policies, as well as enforceable building codes.

The customer shall coordinate and pay for electrical inspections. The customer shall pay the cost of the electrical power necessary to operate the system.

The control panel installation must be in accordance with local electrical codes and pass an electrical inspection by the local control authority. The manufacturer shall furnish a schematic diagram of the control panel. The control panel shall include an alarm light and an audible alarm.

Inlet connections shall be made according to the manufacturer specification. These connections must also be approved by AUB. Discharge piping will be installed and located according to AUB specifications. The specifications will be determined by AUB to meet each site requirement. AUB will require a check valve and a shut-off valve to be installed on each outlet pipe. The valves will be located at the property line and installed in an AUB approved valve vault.

AUB shall conduct an inspection of the work (reasonable advance notice required) prior to and during installation if not installed by AUB personnel. The inspection shall include installation and operation of the unit (excluding electrical service) after primary power is established.

The grinder pump system may be placed in service once it has passed AUB’s inspection. The grinder pump will not be placed into the basin until all construction activities are complete if the assembly is in a new development. AUB shall assume maintenance of all equipment associated with the grinder pump assembly excluding wiring and disconnect to the control panel.

The customer shall not alter, modify or tamper with equipment that AUB maintains.

Any alterations or relocation of components for the customer’s benefit must be approved by AUB. Approved alterations or relocations will be performed at the customer’s expense.

The customer shall not construct any structure or other permanent improvement that shall prevent AUB from maintaining the system.

The customer shall grant AUB a right of way and unencumbered access to enter upon the customer's property to maintain the grinder pump system.

## **5.2 Proper Use**

The customer shall reimburse AUB for the cost of materials, labor and equipment required to repair any components of the system damaged by the customer's negligence or actions. Specifically, AUB will require a customer to pay for damage to a grinder pump system caused by non-compliance with AUB Wastewater Division Policy AUB-02-01, Prohibitions and Limitations on Wastewater Discharges. AUB will also require a customer to pay for damages caused by allowing the following materials to enter a grinder pump system:

- Glass, metal, wood, seafood shells.
- Diapers, socks, rags, or cloth of any kind.
- Feminine hygiene products or needles.
- Plastic objects (toys, eating utensils, etc.)
- Toxic or corrosive chemicals, solvents or degreasing chemicals.
- Gasoline, kerosene, fuel-oil, paint thinner.
- Antifreeze, lubricating oil, or grease.
- Cooking fat (lard, oil, grease)
- Cat litter, aquarium gravel.

## **5.3 Alarm Conditions**

A grinder pump system is equipped with an audible alarm and alarm light that are activated when problems with the system occur. A customer should respond as follows:

- Immediately discontinue water use to prevent overflows and sewage backups into your home or yard.
- Call AUB at (423) 745-4501 and report the problem.

## **5.4 When Customer Is Away**

If a customer will be away from home for several days, these steps should be followed to minimize the opportunity for problems:

- Replace the wastewater in the tank with clean water to minimize odors. To do this, run water from an inside faucet long enough for the grinder pump to begin running (someone will need to go outside and listen to verify the pump is running).
- After the pump starts, turn the inside faucet off. The pump will run until the tank is nearly empty and will shut off. This process will cleanse the pump and pipes and leave the tank holding a minimum amount of clean water.

## **5.5 Power Failures**

During power failures, the grinder pump system will not be able to operate. The tank has some holding capacity, but water use must be severely restricted until power has been restored.

Athens Utilities Board

<b>Division of Wastewater – Policies and Procedures Manual</b>	
<b>Standard Policies and Procedures</b>	
<b>Policy Number – AUB-02-07</b>	<b>Revision Number: 5</b>
<b>Subject Collection System Development and Alterations</b>	<b>Effective Date: 7/01/13</b>
	<b>Superintendent Approval:</b>
	<b>General Manager Approval:</b>

**1.0 PURPOSE AND SCOPE**

The purpose of this policy is to standardize Athens Utilities Board’s (AUB) approach to review and approval of all development within the AUB service area, and to standardize the policy regarding cost sharing and agreements for the wastewater collection system. This policy applies to all residential and industrial customers who are physically connected to or have the potential to be physically connected to the AUB Wastewater Collection System.

**2.0 REFERENCES**

(1) Athens Municipal Code, Title 18 Water and Sewers

**3.0 GENERAL**

Final review and approval of the wastewater collection system and any exceptions to this policy will be by the local control authority.

The specifications of all materials and the manner in which all appurtenances are laid, shall meet the inspection and approval of the local control authority or their designee.

All wastewater construction plans for subdivisions shall include service from AUB’s existing wastewater collection system to the property line of each proposed lot. There shall be a marked clean out installed at each property line with a short piece of pipe stubbed out of the back of each clean-out.

The entire cost and expense of installing the required wastewater collection system shall be borne by the developer. This includes the fee for tapping onto AUB’s existing system. Additionally, the developer is financially responsible for all maintenance and repairs on such mains for one year.

**4.0 DEFINITIONS**

**AUB** – the Athens Utilities Board, and its duly authorized employees, agents, and representatives **Board** – the Chairman and all Commissioners but does not include any employees

**Local Control Authority** – Superintendent of Water and Wastewater or duly authorized representative

**Customer** – any person discharging waste to AUB’s Wastewater Collection System and wastewater treatment facilities

**WWTP** – Wastewater Treatment Plant, facilities owned and operated by AUB

**TDEC** – Tennessee Department of Environment and Conservation

## **5.0 POLICY/PROCEDURES**

### **5.1 Review and Approval**

Developers shall submit plans for the proposed wastewater collection system installation to the local control authority in a timely manner for proper review and approval. Developers are responsible for TDEC approval of all proposed wastewater collection systems. All necessary surveys and easements must be recorded and permits obtained at the developer's expense.

All wastewater collection system construction plans for subdivisions shall include service from the main to the property line of each proposed lot. The end of each stub behind the clean out shall be properly marked.

The specifications of all material shall be inspected and approved by the local control authority or their designee. No wastewater collection system main shall have less than an 8" pipe diameter.

All plans will receive an assessment of final approval, conditional approval, or be rejected based upon the findings of the technical review. Conditional approval does not constitute permission to proceed with construction and indicates that minor design changes are needed in order to receive final approval. Only assessments of final approval, acknowledged by the signature of the local control authority, indicate acceptability of the design for construction purposes.

### **5.2 Installation Inspection**

An AUB inspection is required during all construction activities involving the wastewater collection system. Inspectors are responsible for the following: ensuring that all construction is performed according to the approved plans; ensuring that all materials meet specifications set by the Board; making field change requests to the local control authority upon discovering hidden features or unforeseen circumstances that require changes to the approved plans; and recording all changes to the approved plans.

### **5.3 Cost**

The entire installation cost and expense for the required wastewater collection system shall be borne by the developer. This includes the fee for tapping and installing clean-outs on the system to serve each lot.

Upon completion of the inspected installation, all wastewater collection lines (including services) must pass an air test, and manholes must pass a vacuum test. The developer must provide to the local control authority a set of as-built drawings, once the system passes all tests. These drawings should include detailed, accurate measurements of lines between manholes, depth of lines, manholes and stub-outs along with measurements from manholes to taps for services and measurements from the taps to the stub-outs behind the clean-outs.

The fees for tapping the system to serve each lot will be applicable when AUB supplies inspection.

Upon the completion of construction and final inspection, the developer must submit to AUB a set of 'As-built' plans that reflect any and all changes to the original approved design. The developer must then sign a Transfer Agreement Statement transferring the water distribution system to AUB before water service is provided.

The developer is financially responsible for all maintenance on the newly installed system for one year.

<b>Division of Wastewater – Policies and Procedures Manual</b> <b>Standard Policies and Procedures</b>	
<b>Policy Number – AUB-02-08</b>	<b>Revision Number: 5</b>
<b>Subject</b> <b>Septage Receiving Policy</b>	<b>Effective Date: 7/1/13</b>
	<b>Superintendent Approval:</b>
	<b>General Manager Approval:</b>

### 1.0PURPOSE AND SCOPE

The purpose of this policy is to outline established the policies and procedures of Athens Utilities Board (AUB) for accepting septage waste for treatment. This policy applies to all septage haulers serviced by AUB.

### 2.0REFERENCES

- (1) Athens Municipal Code Title 18 Water and Sewers

### 3.0GENERAL

All septage haulers are subject to the rates as defined in the AUB Schedule of Rates and Fees.

### 4.0DEFINITIONS

**AUB** – the Athens Utilities Board, and its duly authorized employees, agents, and representatives **Board** – the Chairman and all Commissioners but does not include any employees

**Local Control Authority** – Superintendent of Water and Wastewater or duly authorized representative

**Customer** – any person discharging wastes to AUB’s Wastewater Collection System and wastewater treatment facilities

**WWTP** – Wastewater Treatment Plant, facilities owned and operated by AUB

### 5.0POLICY/PROCEDURES

Athens Utilities Board will operate a septage-receiving station at its North Mouse Creek Wastewater Treatment Plant. Normal hours of operation for the septage receiving unit will be 7:30 AM till 3:00 PM. Trucks should arrive early enough to complete unloading during the normal hours of operation. One to two hours unloading time should be expected. Unloading time depends upon the consistency of the septage.

The North Mouse Creek Wastewater Treatment Plant is staffed by only two operators each week. The operators’ duties occasionally take them away from the facility for short periods of time. Unloading will not be allowed unless an operator is present at the facility.

Septage loads received at the North Mouse Creek Facility will be subject to all of the constraints and requirements of the Athens Sewer Use Ordinance. Athens Utilities Board will accept only domestic septage. The plant operator cannot make any exceptions to accommodate unloading. The operator on duty may refuse a load of septage based on current conditions at the wastewater plant, even when the domestic septage meets the Athens Sewer Use Ordinance.

The septage hauler's equipment must have the ability to connect to the septage receiving station through the unit's pinch valve. The septage-receiving unit requires that the tanker truck pressure feed the septage-receiving unit. No septage will be received other than through the septage-receiving unit.

Should the septage receiving unit be out of service or in need of repair, AUB will not accept septage.

The procedure for unloading septage waste at North Mouse Creek WWTP will be:

The septage hauler should contact the facility operator.

The septage hauler will obtain a sample from the tank for the plant operator. The plant operator will measure the pH of the sample and may retain the sample for additional laboratory evaluation.

The septage hauler must complete a manifest. The manifest will include the name, address and phone number for each residential septic tank that comprises the septage load.

The hauler will unload only after receiving approval from the plant operator on duty.

The septage hauler must remain at the septage-receiving station. In the event of equipment failure or an overflow, the septage hauler will immediately stop discharging and notify the plant operator.

Disconnecting from the unit leaves a small amount of septage on the unloading pad. The driver will clean the unloading pad after disconnecting from the septage receiving station. Septage should be directed to the catch rack located in the unloading pad.

The plant operator will rarely witness the operation of the septage-receiving unit. The septage hauler should report any unusual operation of the septage-receiving unit to the operator on duty before leaving the facility.

Septage Haulers will be billed monthly for use of the septage-receiving unit. The charge for each load of septage will be based upon the Athens Utilities Board surcharge rates for compatible pollutants and the volume of the tanker. Athens Utilities Board will periodically analyze samples to determine an average strength for domestic septage.

Adjustments to AUB unloading rates (as published in AUB schedule of rates and fees) can be given for partially-filled septage tankers. For an adjustment to be given, the operator on duty must determine the approximate volume of septage contained in the tanker. Septage will not be accepted from a Septage Hauler with a delinquent account.



AUB-02-09  
Forms/Drawings/Specifications  
For Division of Wastewater

A G R E E M E N T  
WATER AND WASTEWATER LINES

THIS AGREEMENT, made and entered into this the \_\_\_\_ day of \_\_\_\_\_ 20\_\_, by and between \_\_\_\_\_ hereinafter called the “Developer”, and Athens Utilities Board with offices at 100 New Englewood Road, Athens, Tennessee, hereinafter called the “Board”.

The “Developer” does hereby convey to Athens Utilities Board, Division of Water and Wastewater, Athens, Tennessee, the following amount of pipe, fittings, and appurtenances installed within the property known as \_\_\_\_\_, located on \_\_\_\_\_ in McMinn County, Athens, Tennessee.

WATER LINE: (indicate material: DI, PVC, HDPE, etc.)

\_\_\_\_ L.F. \_\_\_\_ Inch \_\_\_\_\_ Pipe  
\_\_\_\_ L.F. \_\_\_\_ Inch \_\_\_\_\_ Pipe  
\_\_\_\_ Each \_\_\_\_ Inch Gate Valves  
\_\_\_\_ Each \_\_\_\_ Inch Valve W/Box

WASTEWATER LINE: (indicate material: DI, PVC, HDPE, etc.)

\_\_\_\_ L.F. \_\_\_\_ Inch \_\_\_\_\_ Pipe

THIS AGREEMENT, also includes a 20 foot easement extending 10 feet each side of said lines to the “Board” for the purpose of performing maintenance of said line.

The Athens Utilities Board, Division of Water and Wastewater, hereby agrees to accept said line into its system, and will be responsible for future maintenance of said line.

CUSTOMER  
BY: \_\_\_\_\_  
DATE: \_\_\_\_\_  
WITNESS:  
BY: \_\_\_\_\_  
DATE: \_\_\_\_\_

ATHENS UTILITIES BOARD  
BY: \_\_\_\_\_  
DATE: \_\_\_\_\_  
WITNESS:  
BY: \_\_\_\_\_  
DATE: \_\_\_\_\_

**CONVEYANCE AGREEMENT**

This Conveyance Agreement is executed as of the \_\_\_\_ day of \_\_\_\_\_, 20\_\_, by and between \_\_\_\_\_ (“Developer”) and ATHENS UTILITIES BOARD, municipal corporation with offices at 100 New Englewood Road, Athens, TN (“Board”).

**WITNESSETH:**

WHEREAS, Developer does herein convey to Board the following amount of personal properties and/or fixtures, which have been placed and installed within the property, known as \_\_\_\_\_.

NOW, THEREFORE, for and in consideration of the premises set forth herein and other good and valuable considerations, the receipt and sufficiency of which are hereby acknowledged, the parties hereto agree as follows:

1. Developer does hereby convey unto Board all personal property and fixtures set forth on Exhibit A hereto.
2. Developer does hereby convey unto Board an easement extending 10 feet each side of the water line where the water lines are not within existing public right of way for the purpose of performing maintenance of the water line herein conveyed.
3. Board hereby accepts the water lines into its system and does hereby accept the personal properties and fixtures set forth on Exhibit A.
4. Board shall be responsible for any future maintenance of the water line and system and does hereby accept the same as conveyed.

EXECUTED into this \_\_\_\_ day of \_\_\_\_\_, 20\_\_.

ATHENS UTILITIES BOARD

BY: \_\_\_\_\_  
Eric T. Newberry, General Manager

WITNESS: \_\_\_\_\_ Dated this \_\_\_\_ day of \_\_\_\_\_, 20\_\_

DEVELOPER

BY: \_\_\_\_\_ Its: \_\_\_\_\_

WITNESS: \_\_\_\_\_ Dated this \_\_\_\_ day of \_\_\_\_\_, 20\_\_.

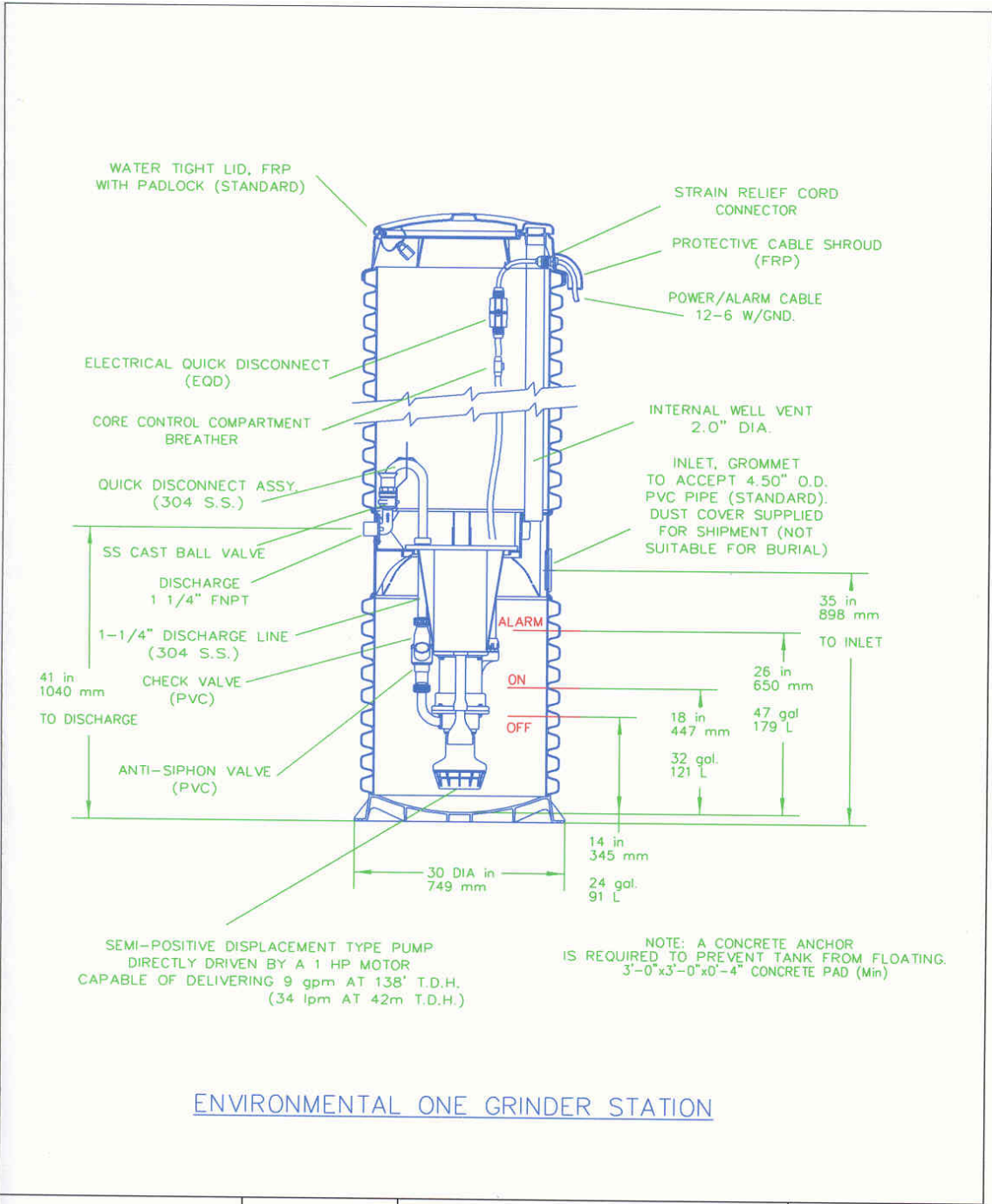

ENVIRONMENTAL ONE GRINDER STATION

ATHENS UTILITIES BOARD CONSTRUCTION STANDARDS	REVISED:	ENVIRONMENTAL ONE GRINDER STATION	DRAWING NO.
			AUB-G.PUMP 1

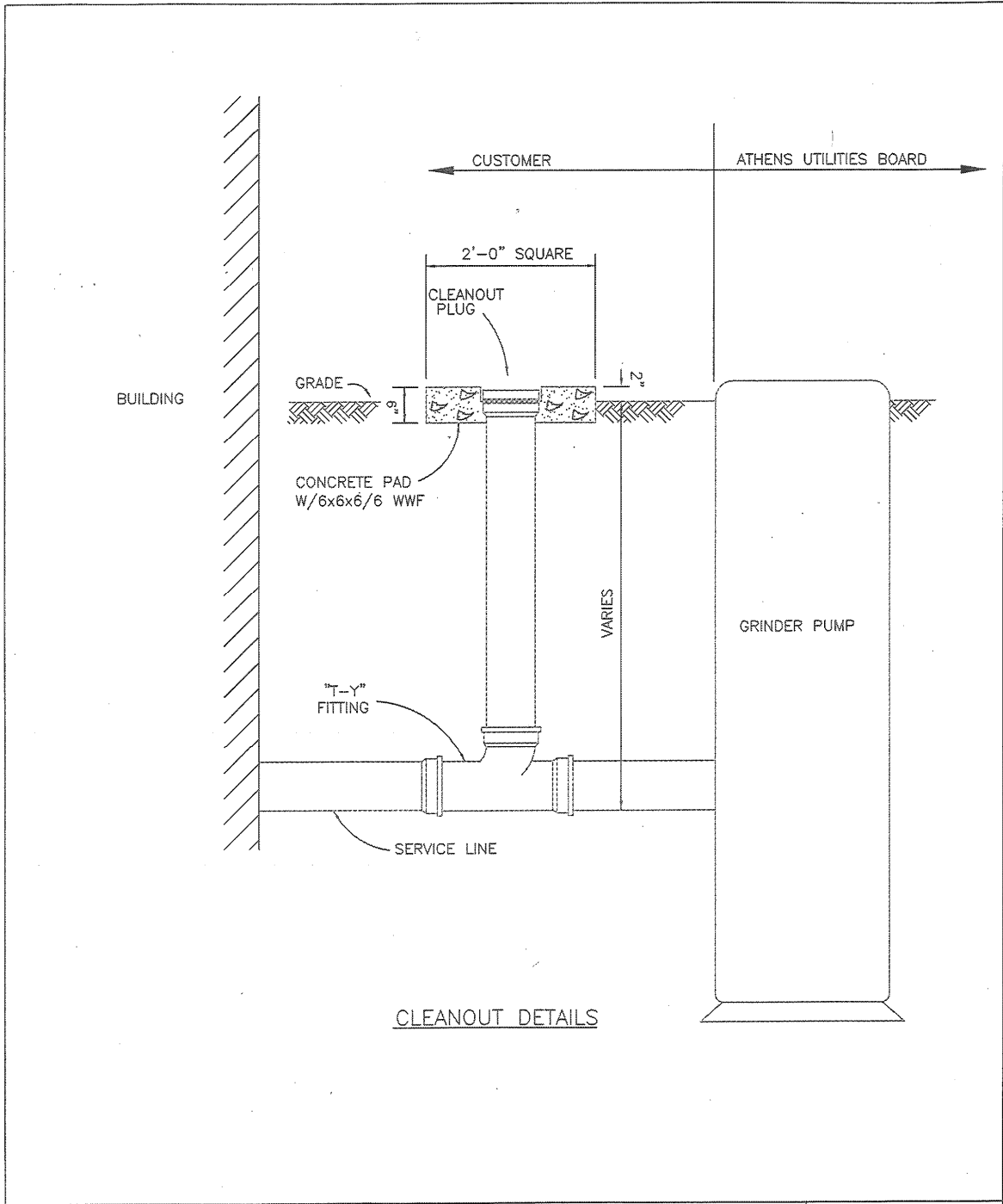

ATHENS UTILITIES BOARD CONSTRUCTION STANDARDS	REVISED:	GRINDER PUMP INSTALLATION	DRAWING NO.
			AUB-GPI 1

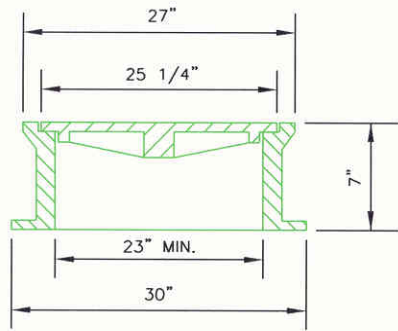

SECTION

NON-TRAFFIC

RING 105 lbs.  
COVER 105 lbs.  
TOTAL 210 lbs.

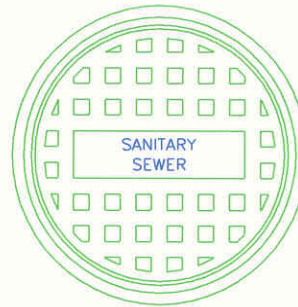

TOP VIEW

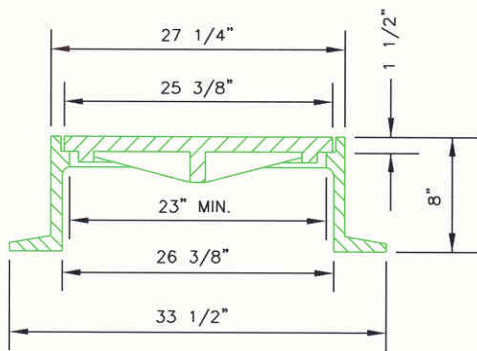

SECTION

TRAFFIC

RING 190 lbs.  
COVER 150 lbs.  
TOTAL 340 lbs.

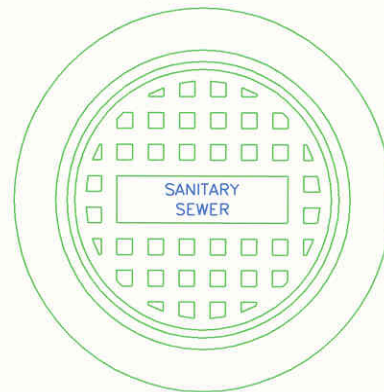

TOP VIEW

ATHENS UTILITIES BOARD CONSTRUCTION STANDARDS	REVISED:	TRAFFIC & NON-TRAFFIC MANHOLE FRAME & COVER	DRAWING NO.
			AUB-MH-FC 1

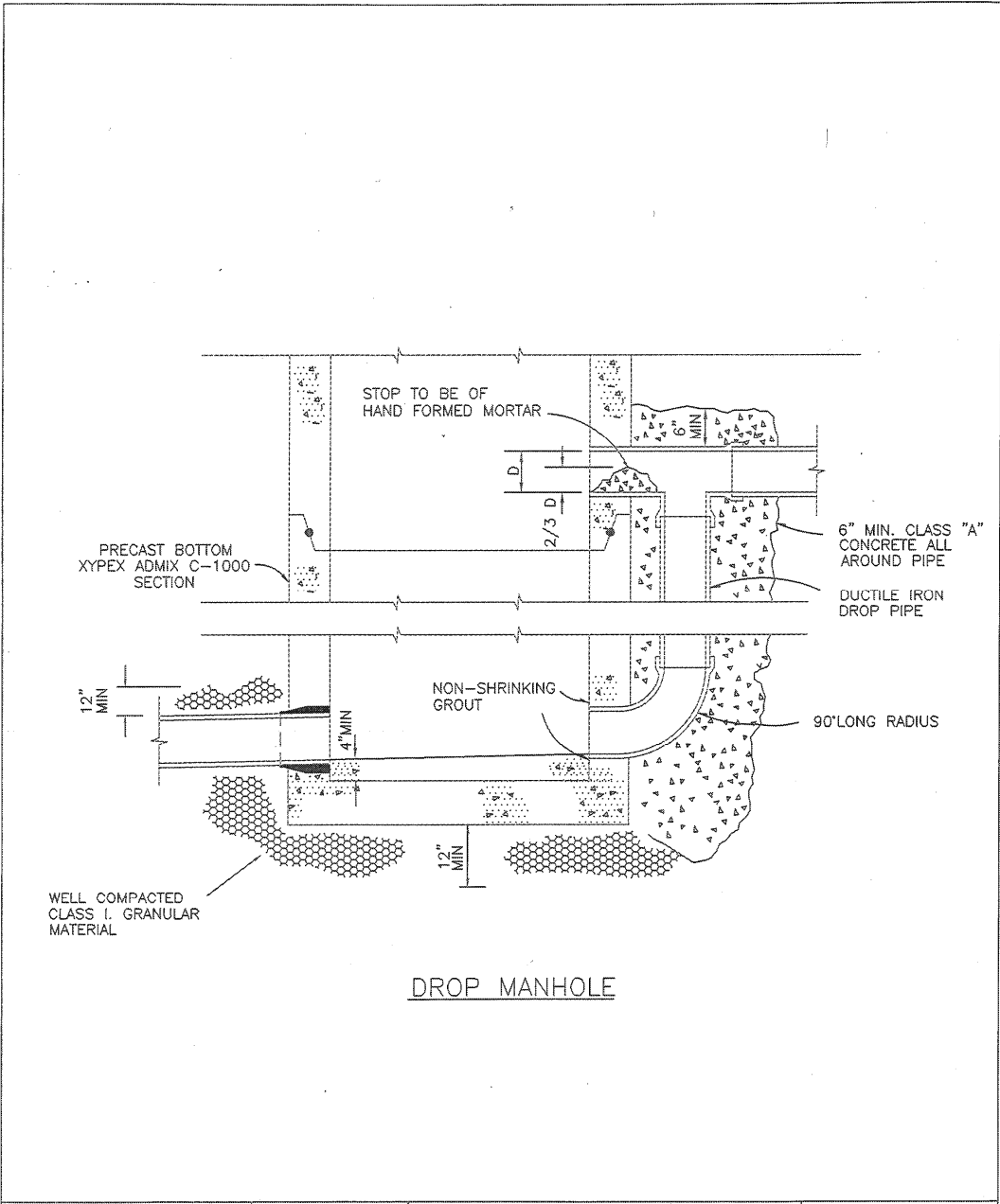

ATHENS UTILITIES BOARD CONSTRUCTION STANDARDS	REVISED:	DROP MANHOLE XYPEX ADMIX C-1000	DRAWING NO. AUB-MH-D 1
--------------------------------------------------------	----------	------------------------------------	------------------------------

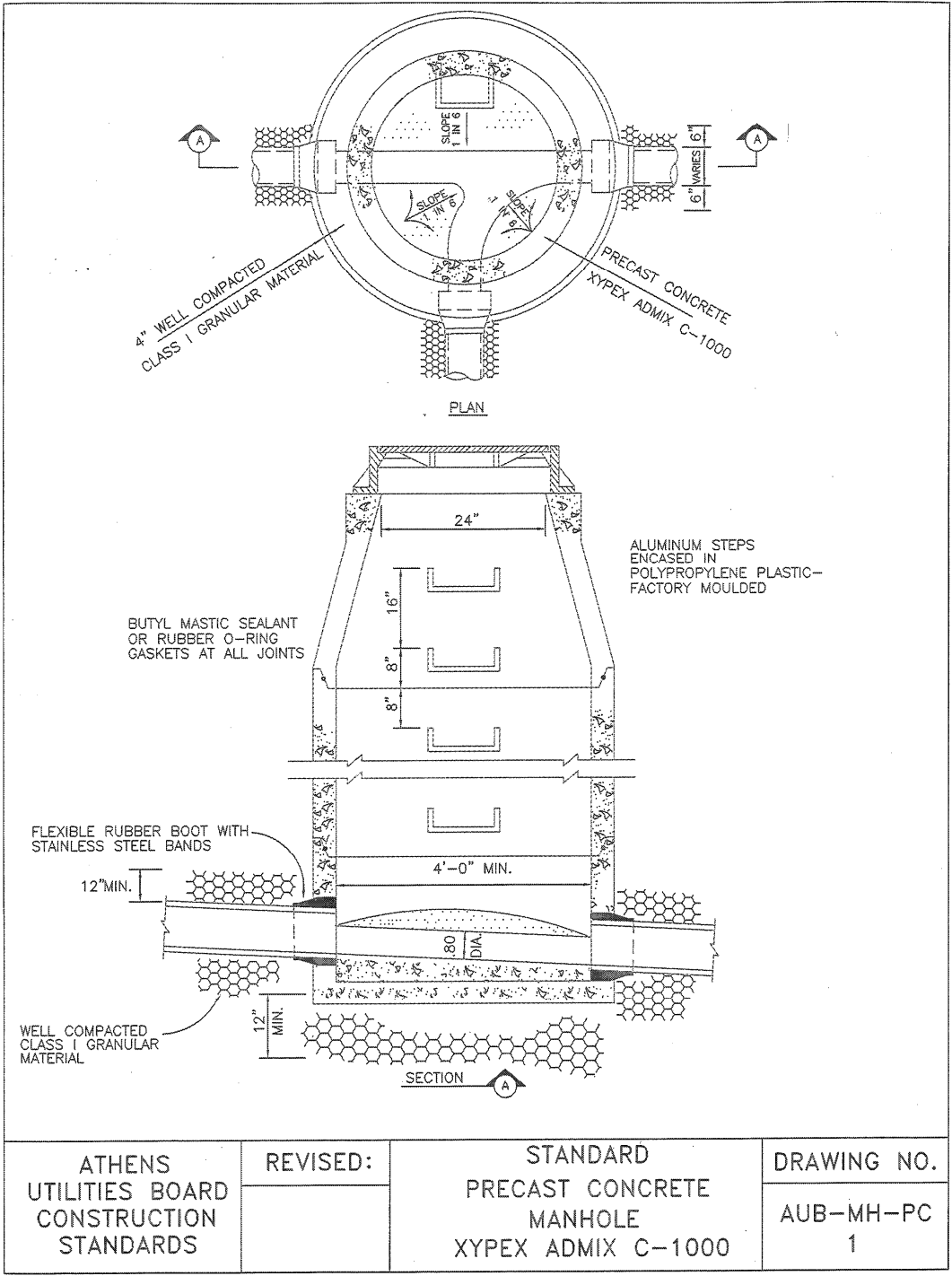



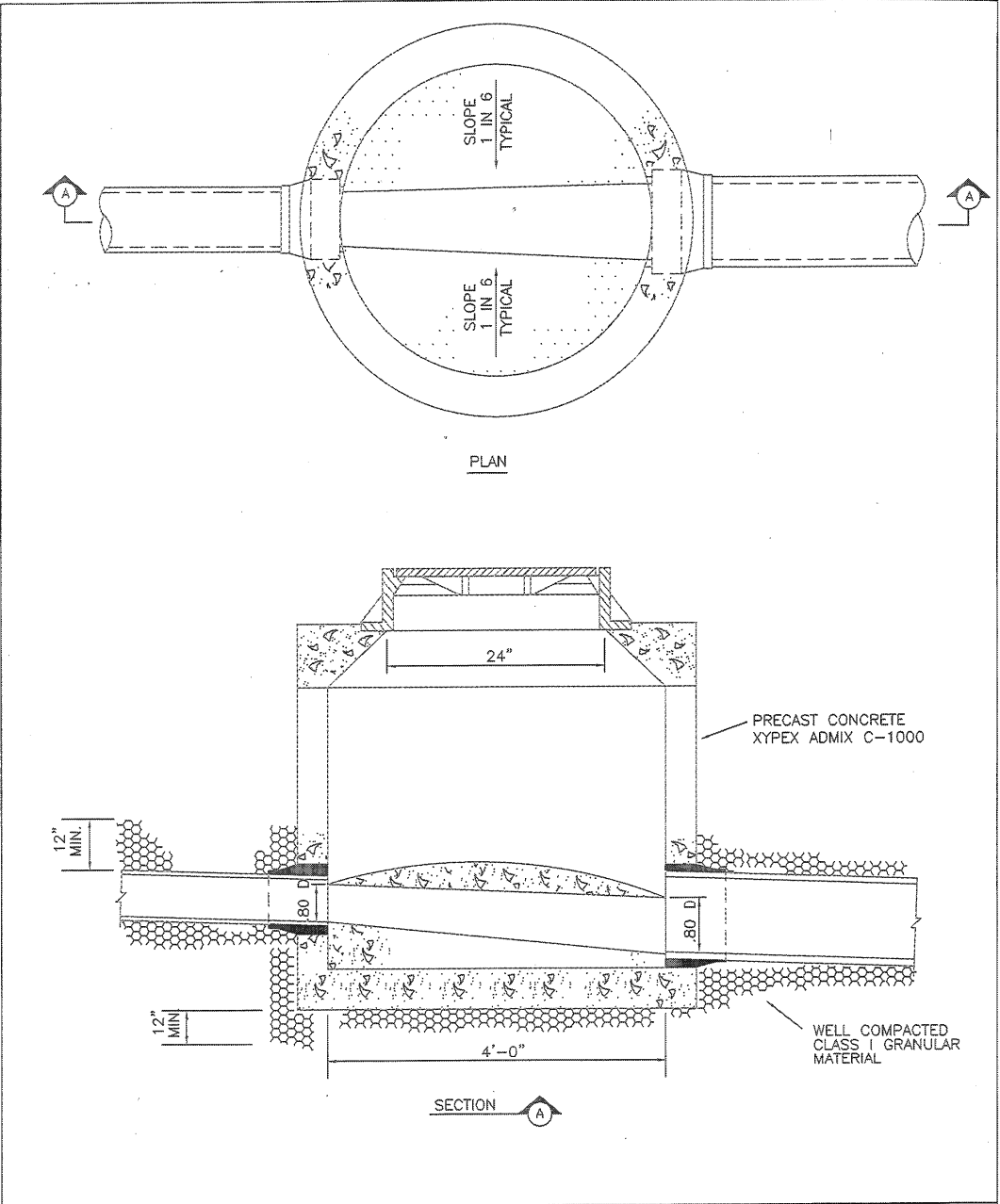

ATHENS UTILITIES BOARD CONSTRUCTION STANDARDS	REVISED:	SHALLOW PRECAST CONCRETE MANHOLE XYPEX ADMIX C-1000	DRAWING NO.
			AUB-MH-PC 2

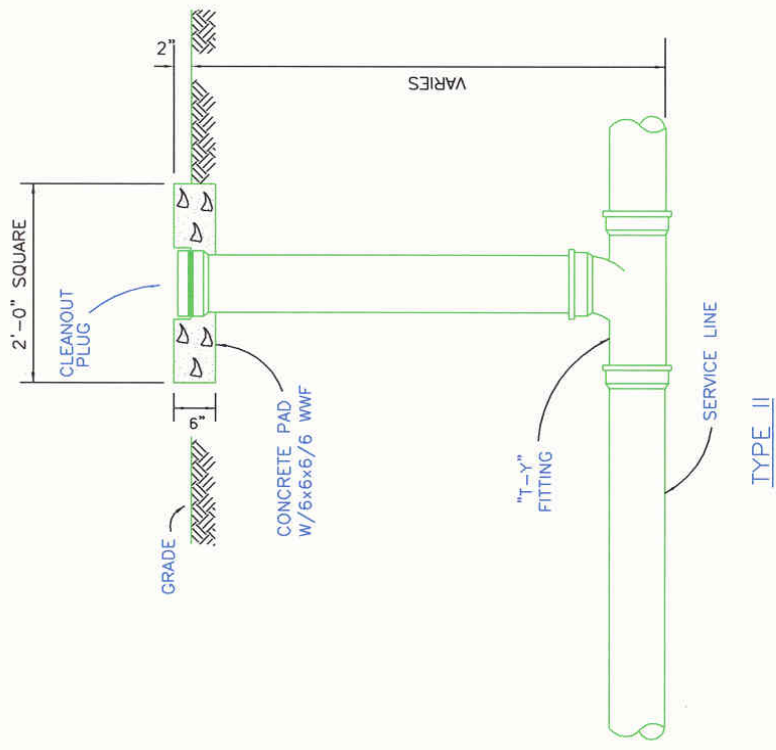

TYPE II

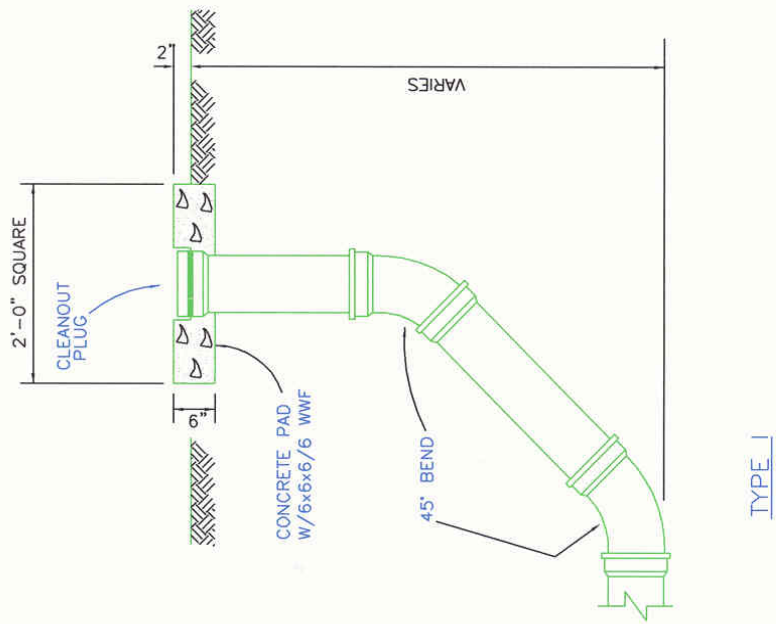

TYPE I

CLEANOUT DETAILS

ATHENS UTILITIES BOARD CONSTRUCTION STANDARDS	REVISED:	SEWER CLEANOUT	DRAWING NO.
			AUB-SC 1

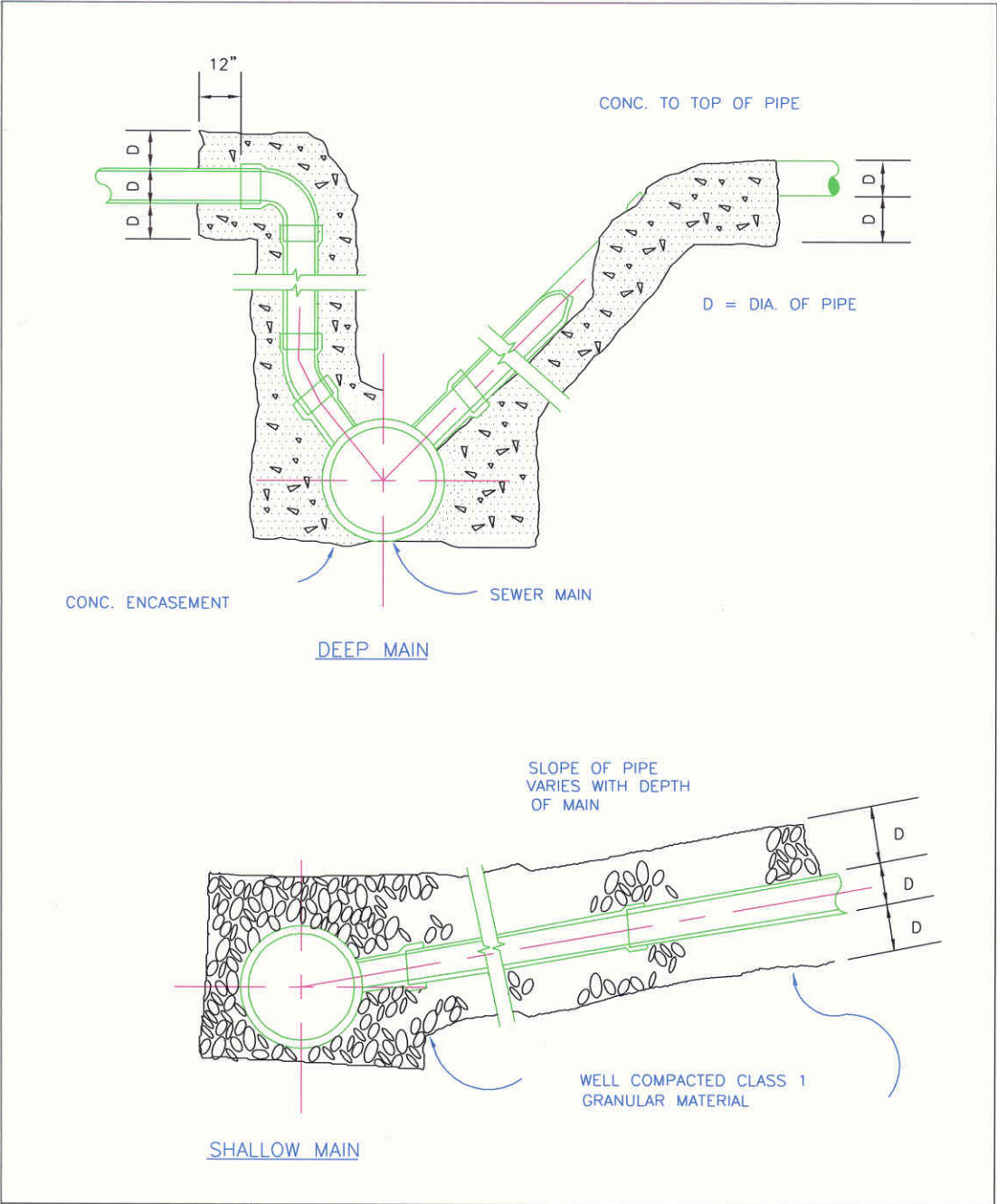

ATHENS UTILITIES BOARD CONSTRUCTION STANDARDS	REVISED:	SEWER SERVICE CONNECTION	DRAWING NO.
			AUB-SSC 1

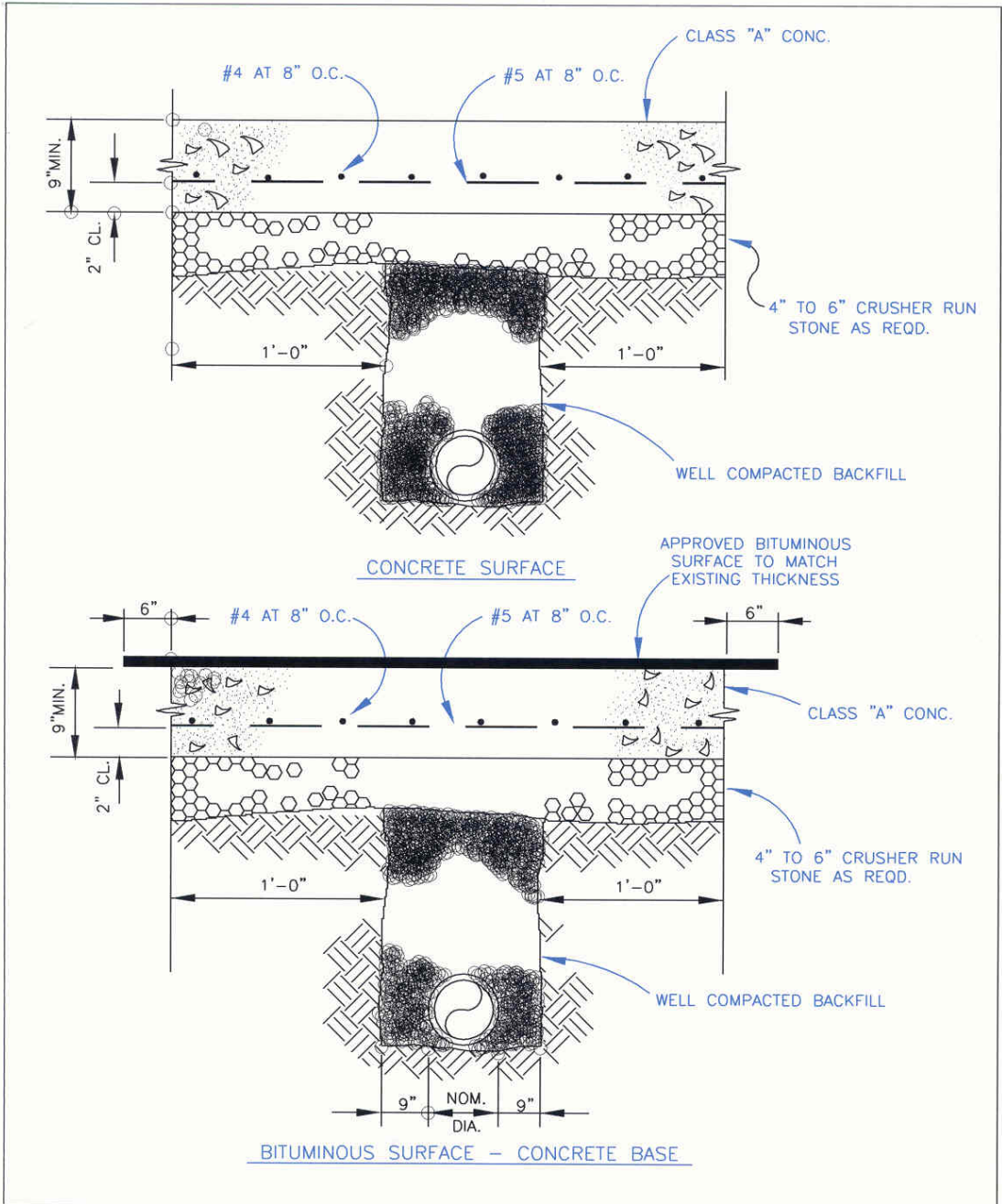

ATHENS UTILITIES BOARD CONSTRUCTION STANDARDS	REVISED:	PAVEMENT REPLACEMENT BACKFILL	DRAWING NO.  AUB-PR-B 2
--------------------------------------------------------	----------	-------------------------------------	----------------------------------

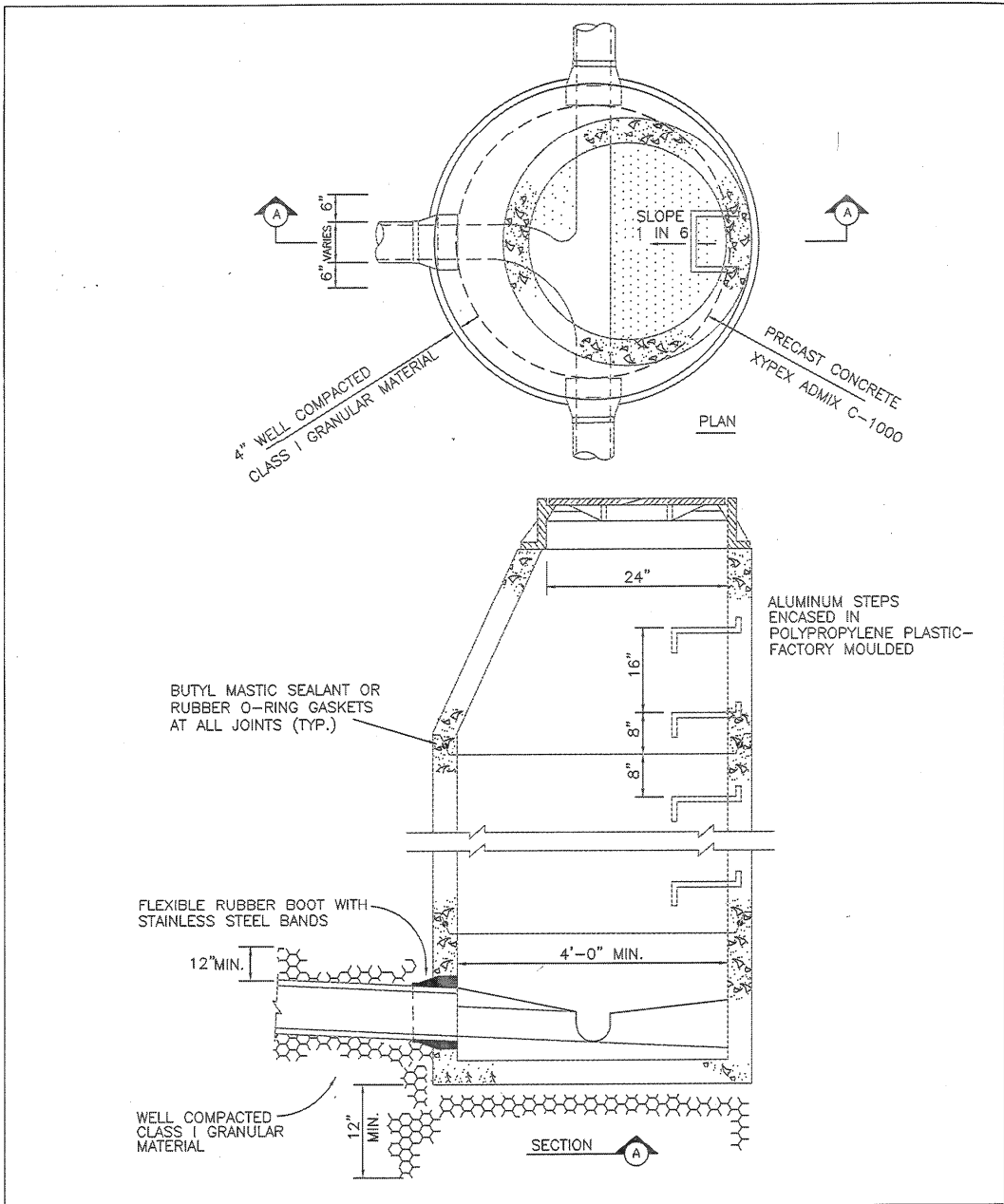

ATHENS UTILITIES BOARD CONSTRUCTION STANDARDS	REVISED:	OFFSET PRECAST CONCRETE MANHOLE XYPEX ADMIX C-1000	DRAWING NO. AUB-MH-PC 3
--------------------------------------------------------	----------	-------------------------------------------------------------	-------------------------------

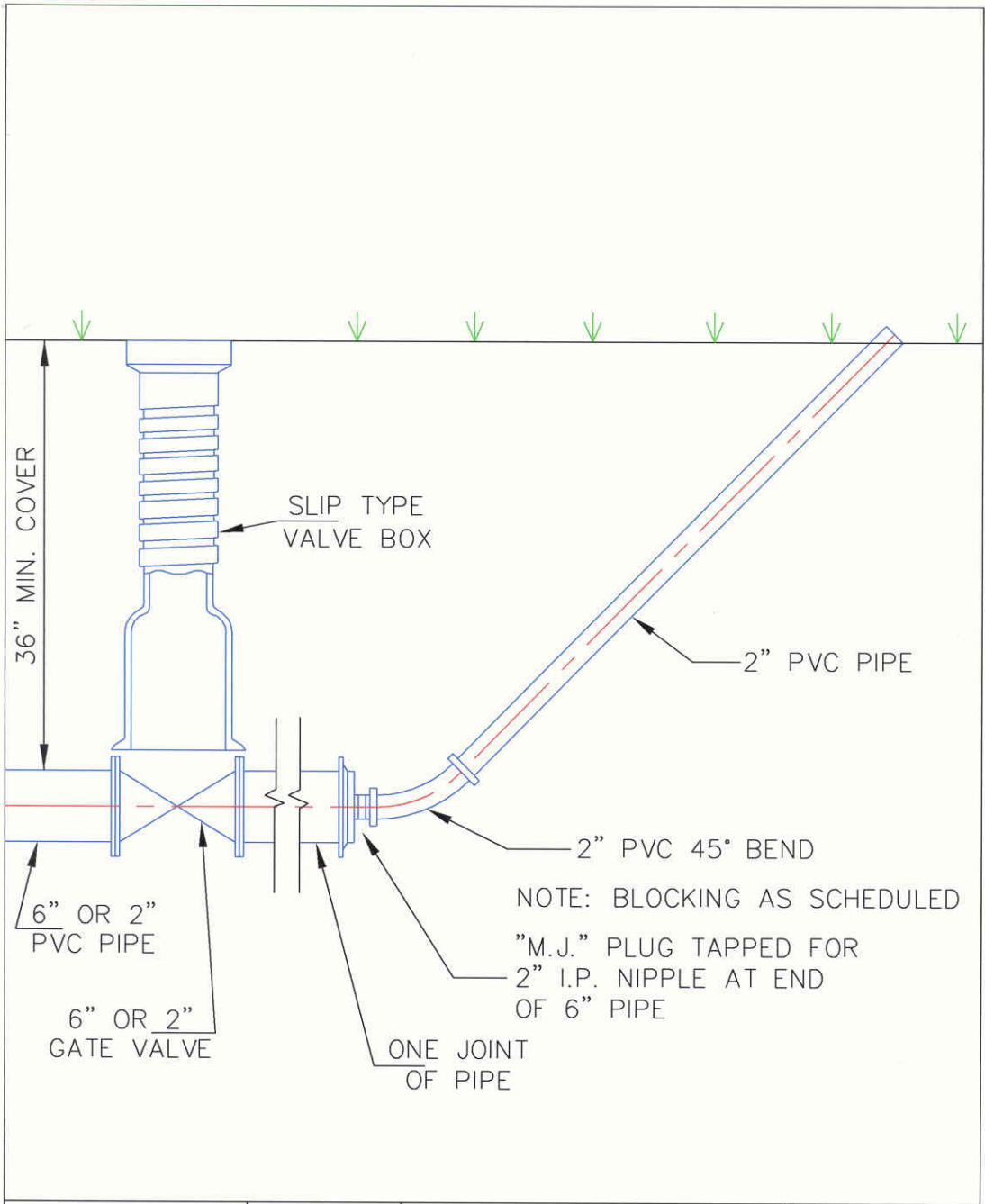

ATHENS UTILITIES BOARD CONSTRUCTION STANDARDS	REVISED:  	6" OR 2" BLOW-OFF ASSEMBLY	DRAWING NO. AUB-BO-A 1
--------------------------------------------------------	------------------	----------------------------------	------------------------------